



LIMA

1988/89

FS 150 ANNI-YEARS

Le ferrovie Railways

EDIZIONE ITALIANA, SCALA HO/N
ENGLISH INTERNATIONAL EDITION, HO/N SCALE

NEW 89**6** Articoli
Items

INTEGRATO DI FERROVIE MODELLO

LIMA INTEGRATED MODEL RAILWAY SYSTEM

Alla Lima si è molto orgogliosi dei successi conseguiti in questi ultimi anni. Successi tecnici, che hanno portato la qualità delle ferrovie in miniatura Lima a meritare l'assenso dei modellisti e dei collezionisti più esigenti in tutto il mondo. L'affidabilità delle parti elettriche e meccaniche e l'elevato grado di finitura di ogni singolo elemento delle ferrovie Lima sono attribuibili in gran parte all'impegno di tecnici e di maestranze di prim'ordine, ma anche all'adozione di tecnologie produttive d'avanguardia e di procedure di controllo qualità mai prima sperimentate.

Lima take much pride in recording their tremendous technical successes in model railways during the last years, which have attracted the most exacting modellers and collectors all over the world who appreciate the high quality of Lima products. The reliability of both electrical and mechanical components, well as the outstanding finish of every single item in the Lima range, has to be attributed to the specialized work of highly skilled technicians and to the introduction of advanced production techniques and strict quality control procedures, unknown a few years ago.

INDICE - INDEX**Pagina - Pages****SCALA - SCALE HO**

Locomotiva a vapore - <i>Steam locomotives</i>	8-9
Italia - <i>Italy</i>	10-21
Franca - <i>France</i>	22-45
Belgio - <i>Belgium</i>	46-49
Svizzera - <i>Switzerland</i>	50-59
Austria - <i>Austria</i>	60-61
Germania - <i>Germany</i>	62-81
Olanda - <i>Netherlands</i>	82-89
Scandinavia - <i>Scandinavia</i>	90-93
Orient Express - <i>T.E.N.</i>	94-95
Carri Merce - <i>Freight Wagons</i>	96-115
Confezioni complementari <i>Additional track layouts</i>	
Binari Standard - <i>Standard tracks</i>	116-118
Binari a norme N.E.M. - <i>Tracks to the N.E.M. rules</i>	119-123
Accessori - <i>Accessories</i>	124-131
	132-141

SCALA - SCALE N

Italia - <i>Italy</i>	142-143
Franca - <i>France</i>	144-149
Svizzera - <i>Switzerland</i>	150-151
Germania - <i>Germany</i>	152-155
Orient Express - <i>T.E.N.</i>	156
Carri Merce - <i>Freight Wagons</i>	157-159
Binari - <i>Tracks</i>	160-161



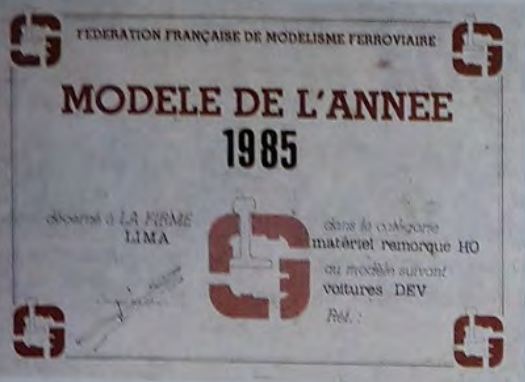

HO - 30 9101 - 30 9102 - 30 9103 - 30 9104



HO - 20 8159L - 20 8160L - 20 8162L



N - 32 0324 - 32 0325 - 32 0326



HO - 14 9727

HO
14 9812



MODELLO DELL'ANNO

MODEL OF THE YEAR



HO 3

TRENI LIMA NEW COUPLING SYSTEMS FOR YOUR LIMA TRAINS

Grazie ad una nuova progettazione, viene dato al modellista ferroviario la possibilità di realizzare, nel modo più fedele vari tipi di aggancio, nel rispetto della tradizionale robustezza e semplicità dei treni LIMA.

Through a new planning, the railway enthusiast has the possibility to execute, in the most faithful way, different types of coupling, always in respect of the traditional strength and simplicity of LIMA trains.

AGGANCO ALLUNGABILE PER SCALA HO A NORME N.E.M.

EXTENSIBLE COUPLING FOR HO SCALE IN N.E.M. RULES

La testa di innesto unificata secondo la normativa N.E.M. 362, montata su di un timone d'allontanamento, consente di ottenere, oltre ai vantaggi del sistema a perno, quelli di un massimo avvicinamento dei vagoni, offrendo così al modellista più esigente un maggior realismo. La costruzione di questo aggancio è secondo le norme N.E.M. 352.

Per passare dal sistema di aggancio standard all'aggancio allungabile è sufficiente inserire il timone e la relativa molla di richiamo nelle sedi del telaio predisposte a tal fine.

The unified coupling head, following N.E.M. 362 rules, mounted on a removal drawbar, allows to get, besides the ones of

the pin system, the advantages of a maximum approach to the coaches. That gives a higher realism to the most demanding enthusiast.

The construction of this coupling is in accordance to the N.E.M. 352 rules.

In order to change from the standard coupling system to an extensible one, it is sufficient to insert the drawbar and the relative return spring in the chassis seats expressly arranged for that purpose.

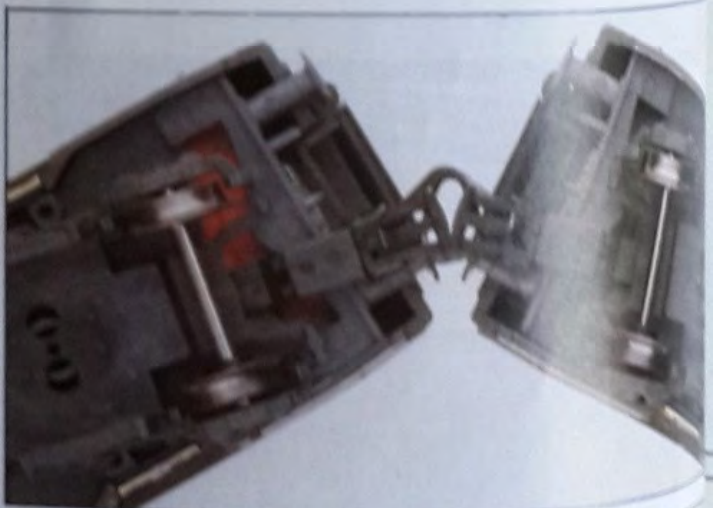
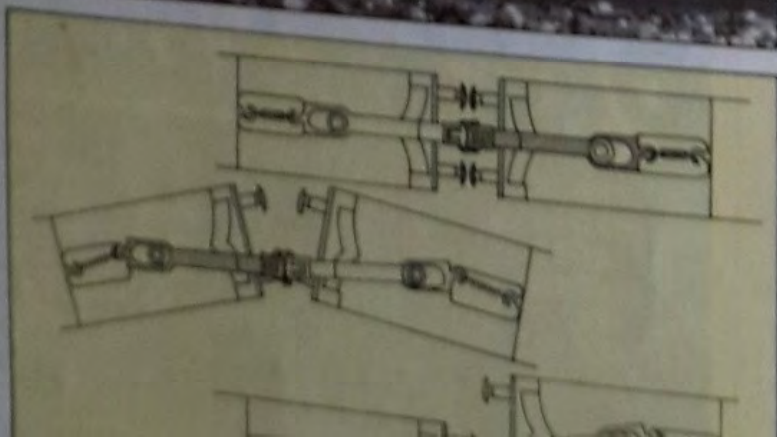

AGGANCI STANDARD PER SCALA HO, A NORME N.E.M.

STANDARD COUPLING IN ACCORDANCE WITH N.E.M. RULES FOR HO SCALE

Ogni modello di produzione LIMA è munito di aggancio standard a norme N.E.M. (disegno N.E.M. n. 360) che consente al materiale rotabile un assetto ravvicinato per un maggior realismo di funzionamento.

Tutti i carrelli del materiale rotabile di nuova produzione e parte di quelli già realizzati, sono con alloggiamento per testate d'aggancio intercambiabili a

norma N.E.M. (disegno N.E.M. n. 362).

Each model manufactured by LIMA has standard couplings in accordance with N.E.M. rules (N.E.M. drawing no. 360) pro-



viding a close coupling for more realism when model railways are in operation.

All bogies on new production models, and partially on others, are supplied with interchangeable

sets for coupling in accordance with N.E.M. regulations (N.E.M. drawing no. 362).

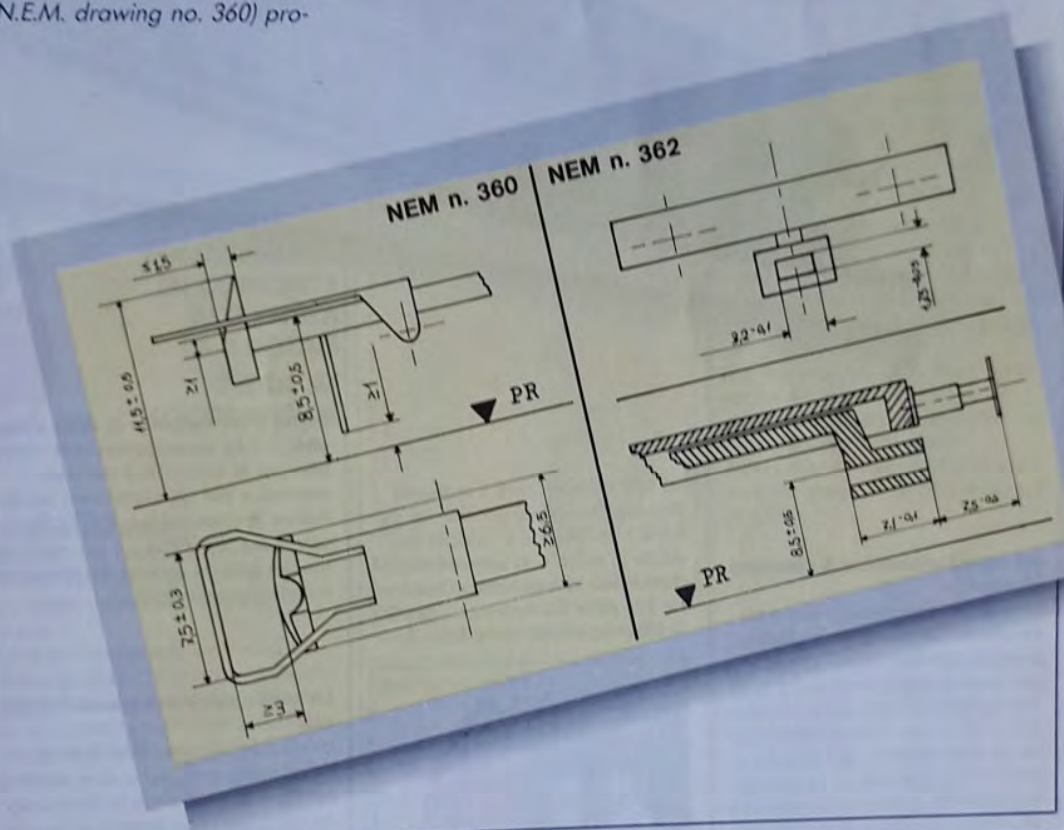

Distanza di assetto di due carrozze Ref. 30 **9104** con ganci LIMA a norme N.E.M. 360/362.

*Distance between coaches Ref. 30 **9104** with LIMA N.E.M. coupling 360/362.*

AGGANCI A BARRA FISSA COUPLING WITH FIXED DRAWBAR

Con questo sistema, appositamente studiato da LIMA per i convogli a composizione bloccata, si è ottenuto il massimo del realismo mediante un particolare brandeggio circolare che, pur precludendo in questi convogli la composizione con altri non appositamente predisposti, consente un maggior avvicinamento accoppiato ad una insuperabile sicurezza e semplicità.

With this system, expressly studied by LIMA for the blocked composition rakes, the maximum realism is reached through a particular close coupling which, even if it prevents the composition of these rakes with others not expressly arranged, allows a better approach besides unbeatable safety and simplicity.



TECNOLOGIA D'AVANGUARDIA

LIMA: ADVANCED TECHNOLOGY



Ad ogni locomotiva il «motore giusto»

La gamma ancora più vasta e diversificata delle locomotive LIMA presenta caratteristiche eccezionali per quanto riguarda lo studio e la realizzazione di una generazione nuova di gruppi motore-trasmissione. Grazie ad essa ogni singola macchina è in grado di riprodurre esattamente, in termini di velocità e di potenza di traino, le prestazioni della locomotiva reale dalla quale trae origine.

Per poter conseguire tali risultati LIMA ha adottato, a seconda dei vari modelli, due diversi tipi di motore, ognuno dei quali è a sua volta accoppiato, secondo i casi, con due differenti trasmissioni. Si è ottenuto così un funzionamento perfettamente equilibrato dei componenti elettrici e meccanici delle singole locomotive, nonché un realismo ancora più spinto sul piano modellistico.

La trasmissione ad ingranaggi diretti

L'ormai famoso motore C...

ed atto ad esercitare il massimo sforzo nello spunto nonché nel traino di treni pesanti a velocità costante in salita e su percorsi accidentati (es. la locomotiva diesel serie 221 delle DB tedesche - art. 20 1640L - riprodotta nella foto 1).

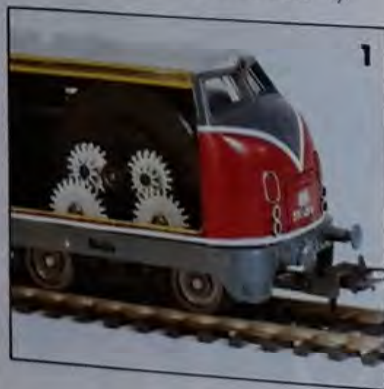

L'altro è un rapporto di **Alta velocità** (1:9,6), espressamente concepito per le locomotive dei treni espressi e per gli elettrotreni ad altissime prestazioni (es. il TGV francese - art. 20 1095L - il cui «spaccato» del gruppo motore-trasmissione è illustrato nella foto 2).

La trasmissione a giunti cardanici

Il secondo motore LIMA è di tipo orizzontale, con uno o due alberi in uscita, a seconda che la trasmissione cardanica con scatola di ingranaggi sia prevista su uno o su entrambi i carrelli della motrice. Con **trasmissione cardanica singola** le ruote del carrello motore sono dotate di cerchi ad alta aderenza, i quali esaltano la potenza che dal

motore viene trasmessa agli
(es. la locomotiva svizzera Re
- art. 20 8156LP nella foto 3).

Con **doppia trasmissione**
nica la trazione è su entrambi
carrelli e le ruote, non dotate
cerchi di aderenza, sono dotate
punti di presa di corrente (es.
comotiva serie 14000 delle SNCF
art. 20 8169L - nella foto 4).
Con questi ultimi due tipi di trasmissione, che consentono potenze di traino analoghe a quella ottenibile con gli ingranaggi diretti a rapporto corto (1:13,68), LIMA può essere su quattro diverse motorizzazioni, quindi su una scelta quanto più precisa del tipo ritenuto più adatta ad ogni singola locomotiva.

3

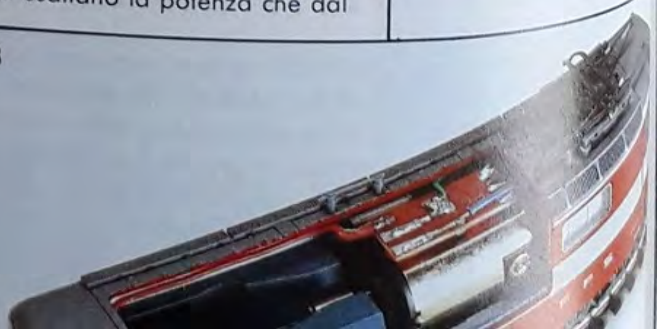

To each locomotive «its own motor»

The even larger and more diversified range of LIMA locomotives introduces outstanding features as regards the development of a fully new generation of motor-transmission units.

Thanks to this new achievement every LIMA locomotive can exactly reproduce, as far as both speed and tractive effort are concerned, the overall performance of the real life prototype.

To obtain such a result LIMA adopted two different types of electric motors, each of them in its turn can be coupled to two different transmissions.

The outcome is a perfectly balanced performance of the locomotive electric and mechanical components together with an even further true-to-life realism.

The direct gear transmission

The famous "G" vertical motor is a high performance unit, to which a direct gear transmission is fitted with choice of two ratios: one is **Super-traction** (1:13,68): as above described, it can deliver the utmost tractive power to haul heavy trains on winding lines at constant speed (for example the German DB diesel locomotive Class 221 - art. No. 20 1640L - shown in the picture 1). The other transmission ratio is the special **High speed** (1:9,6) specially developed for express train locomotives and for high speed, multiple-unit electric trains as well (for example the French TGV - art. No. 20 1095L - whose «cutaway view» of the motor-transmission unit is illustrated in the picture 2).

The universal joint transmission

The other LIMA electric motor is a horizontal unit, either with one or two drive-shafts, connected through universal joints to the gearbox transmission, fitted to one or both locomotive bogies. With **single joint transmission** the motor-bogie wheels are provided with high-adhesion rubber bands which emphasize the power transmitted to the axles (for example the Swiss locomotive Class RE 4/4^{II} - art. No. 20 8156LP in the picture 3). With **double joint transmission** either bogie is fitted with gearbox transmission, while all the bogie wheels, not provided with rubber bands, act as current collectors (for example the French SNCF locomotive Class 14000 - art. No. 20 8169L - in the picture 4).

This new transmission ensures a similar tractive power that is obtained through the direct gear transmission with the 1:13,68 ratio. LIMA can therefore rely upon four different motor-transmission units and then on a wide choice of the proper type to be installed in every single locomotive.



LOCOMOTIVE FUNZIONANTI IN CORRENTE ALTERNATA A 3 ROTAIE 3-RAIL AC LOCOMOTIVES

Tecnica sofisticata

Questo relè costruito con la tecnica S.M.D. (Surface Mounted Device) permette un'estrema miniaturizzazione.

Utilizza componenti elettronici miniaturizzati per la massima affidabilità di funzionamento, con dispositivo di protezione da sovraccarico o da cortocircuito con ripristino automatico.

Meccanica

Il profilo delle ruote e dei bordini è stato ridisegnato appositamente ed è adatto a tutti i binari e scambi del sistema a Corrente Alternata (dis. 3). I pattini di captazione che garantiscono una assoluta sicurezza di funzionamento sono facilmente sostituibili e reperibili come parti di ricambio (foto 4).

Relè inversore elettronico a memoria magnetica

L'inversione di marcia è ottenuta a mezzo di un nuovissimo relè elettronico (foto 1) che memorizza magneticamente, in maniera permanente, l'ultimo senso di marcia impostato dal trasformatore evitando, logicamente, che i picchi di tensione provochino inversione di marcia.

Questo, anche in caso di soste prolungate e senza la necessità di manutenzioni periodiche o di sostituzione di batterie all'interno della motri-

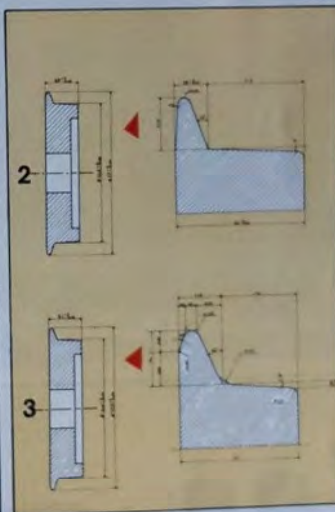
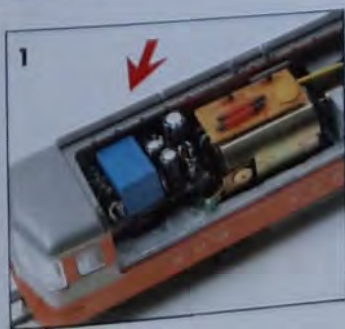

Trazione

I motori appositamente dimensionati garantiscono, specialmente alle minime velocità, un funzionamento progressivo e regolare con elevata potenza di trazione.

Top quality and high technology products

The LIMA 3 AC system is designed for locomotives operating on systems using the 3-rail central contact point system.

The models are not part of the normal production range: they are completely redesigned both technically and mechanically to make them perfectly compatible with AC systems.

Electronic magnetic memory reverser relay

Reversing is achieved by means of a new electronic relay (photo 1) which has a permanent magnetic memory, memorizing the last running direction set on the transformer (and which also logically prevents voltage peaks from changing the running direction). The system operates even

if it has not been used for long periods and without having to carry out maintenance operations or having to replace the batteries inside the locomotive.

Sophisticated technology

The relay is built by means of S.M.D. (Surface Mounted Device) technology and makes it possible to achieve a very high degree of miniaturization.

It is the only one of its type at present on the market which has an overload/short circuit protection device with automatic re-set. It uses miniaturized electronic components, designed to give maximum reliability.

Mechanics

The wheels and wheel flanges have been specially redesigned to suit all tracks and points of the AC system (see drawing 3).

The contact rail shoes (photo 4) conform to the standards of the system and guarantee perfect safety; they are easy to replace and spares are available.

Traction

The motors have been specially redesigned to guarantee a smoothness of operation with very high tractive power.





routine quotidiana, le locomotive a vapore sono ancora le più spettacolari e quelle che evocano maggiormente l'epoca pionieristica della strada ferrata.
 Although they have mostly disappeared from everyday operation, steam locomotives are still the most spectacular and recall the early days of railways.



20 3005L

20 3005L

Locomotiva-tender per servizio di manovra con rooster di colore nero-rosso, lunghezza respingenti mm 110. Supermodel.

Steam tank-locomotive for shunting operation, 2-4-2 wheel arrangement, Black-red liver, length mm 110. Supermodel.



20 3006L

20 3006L

Locomotiva per servizio di manovra con rooster di colore nero-rosso, lunghezza respingenti mm 205. Supermodel.

Steam locomotive for shunting operation, 2-4-2 wheel arrangement, Black-red liver, length mm 205. Supermodel.

**LOCOMOTIVE
DA MANOVRA
SHUNTING
LOCOMOTIVES**

Con la progressiva eliminazione della trazione a vapore negli scali merci e nelle stazioni, tutte le amministrazioni ferroviarie hanno provveduto a mettere in servizio nuove locomotive diesel appositamente progettate per il servizio da manovra. With the slow withdrawal of steam locomotives for shunting operations in both freight yards and passenger stations, all the railway authorities introduced replacement locomotives, specially designed for this purpose.

20 1652L

Locomotiva diesel da manovra delle SNCF con rodiggio B. Lunghezza fuori respingenti mm 119. **Supertrazioni.**

Diesel shunting locomotive of SNCF; B wheel arrangement. Overall length mm 119. **Supertraction.**

20 1653L

Locomotiva diesel da manovra delle DB con rodiggio B; colore rosso-nero. Lunghezza fuori respingenti mm 119. **Supertrazioni.**

Diesel shunting locomotive of DB; B wheel arrangement. Red-black livery. Overall length mm 119. **Supertraction.**

Nel processo di razionalizzazione del parco locomotive intrapreso dalle Ferrovie Germaniche (DR) dopo il 1920, figurava anche l'entrata in servizio della serie di locotender da manovra BR 80, con rodiggio 030.

Con una potenza di 575 HP e un peso di 54,4 tonnellate, hanno disimpegnato per alcuni decenni il servizio negli scali e nelle stazioni di tutta la Germania.

In the rationalization plan developed by the German Railways (DR) since 1920, a new series of shunting tank-locomotives with 0-6-0 wheel arrangement (class 80) was included.

They featured an output of 575 HP and a total weight of 54,4 tons. Built in thousands, they performed both in shunting yards and in passenger stations all over Germany for many years.

20 1700L

Locomotiva-tender serie 80 delle DB, per servizio di manovra; rodiggio 030. Colore nero-rosso. Lunghezza fuori respingenti mm 114.

Supertrazioni. Steam tank-lokomotive Class 80 of DB for shunting operation; 0-6-0 wheel arrangement. Black-red livery. Overall length mm 114. **Supertraction.**

20 1652L



20 1653L



20 1700L



Dal 1936 le Ferrovie dello Stato italiana affidarono l'immagine di maggiore efficienza nella velocità e nel prestigio ai diciotto elettrotreni della serie ETR 200, consegnati entro il 1939.

Proprio in quest'anno, in cui cadeva il primo centenario della introduzione del trasporto ferroviario nel nostro paese, un ETR 200 toccava i 203 Km/h, stabilendo un primato di livello mondiale; nello stesso anno un'altro ETR 200 portò il messaggio tecnico italiano alla Esposizione Universale a New York, attraversando l'Oceano su mezzi navali.

I rotabili di questo gruppo che sopravvissero al conflitto mondiale ripresero servizio sulle principali linee della rete finché, dal 1960, si intraprese un'opera di rimodernamento che portò alla radicale trasformazione degli ETR 200 a tre elementi in ETR 220 a quattro elementi, con adozione di moderni equipaggiamenti elettrici e meccanici nonché variazione dello schema di verniciatura nelle tonalità già felicemente sperimentate sui celeberrimi elettrotreni «Settebello».

I già moderni ETR 220, a cui si affidavano rapidi prestigiosi sulle linee Genova-Trieste e Milano-Bari principalmente, ricevettero dal 1970 nuovi cristalli frontali antiurto che gli procurarono il soprannome «Polifemo», per similitudine con il mitico ciclope monocolo.

Attualmente gli ETR 220 effettuano rapidi di prestigio, tra cui la linea Firenze-Venezia è un evidente esempio.



In this new version there were modern electrical and mechanical equipment and a different livery scheme in the tones already happily tested on the very famous "Settebello" rakes.

The already modern ETR 220, destined mainly to the prestigious express trains on the Genoa-Trieste and Milan-Bari lines, had, starting from 1970, new shockproof wind-screens. This is the reason of the "Polifemo" nickname, for simile with the mythical one-eyed cyclop.

Actually the ETR 220 effect prestigious express services and the Florence-Venice line is the best example.

In 1936 the Italian Railways (FS) entrusted the image of increased efficiency in speed and prestige to the 18 express trains of class ETR 200, delivered during 1939.

Exactly the year, in which the first centenary of the railway transport introduction in our country was celebrated, an ETR 200 reached 203 Km/h, setting up a world record: in the same year another ETR 200 brought the Italian technical message to the world exhibition in New York, crossing the ocean by naval means.

The rakes of this group, which survived the world war, again took service on the main lines of the railway networks.

In 1960 a work of modernization started and brought about the complete transformation of the three-element ETR 200 into the four-element ETR 220.

14 9715

Elettrotreno serie ETR 220 «Polifemo» livrea giallo-verde F.S. **Doppia trasmissione cardanica.**

Rake class ETR 220 "Polifemo", grey-green livery of FS. **Double joint transmission.**



14 9715AC

Modello predisposto per corrente alternata. **Trasmissione cardanica singola.**

Model in AC version. **Single joint transmission.**

14 9716

Elettrotreno Serie ETR 220 livrea grigio-verde F.S. **Doppia trasmissione cardanica.**

Rake class ETR 220 - High speed grey-green livery of FS. **Double joint transmission.**

14 9715

14 9715AC



NEW₈₉

NEW₈₉

14 9716

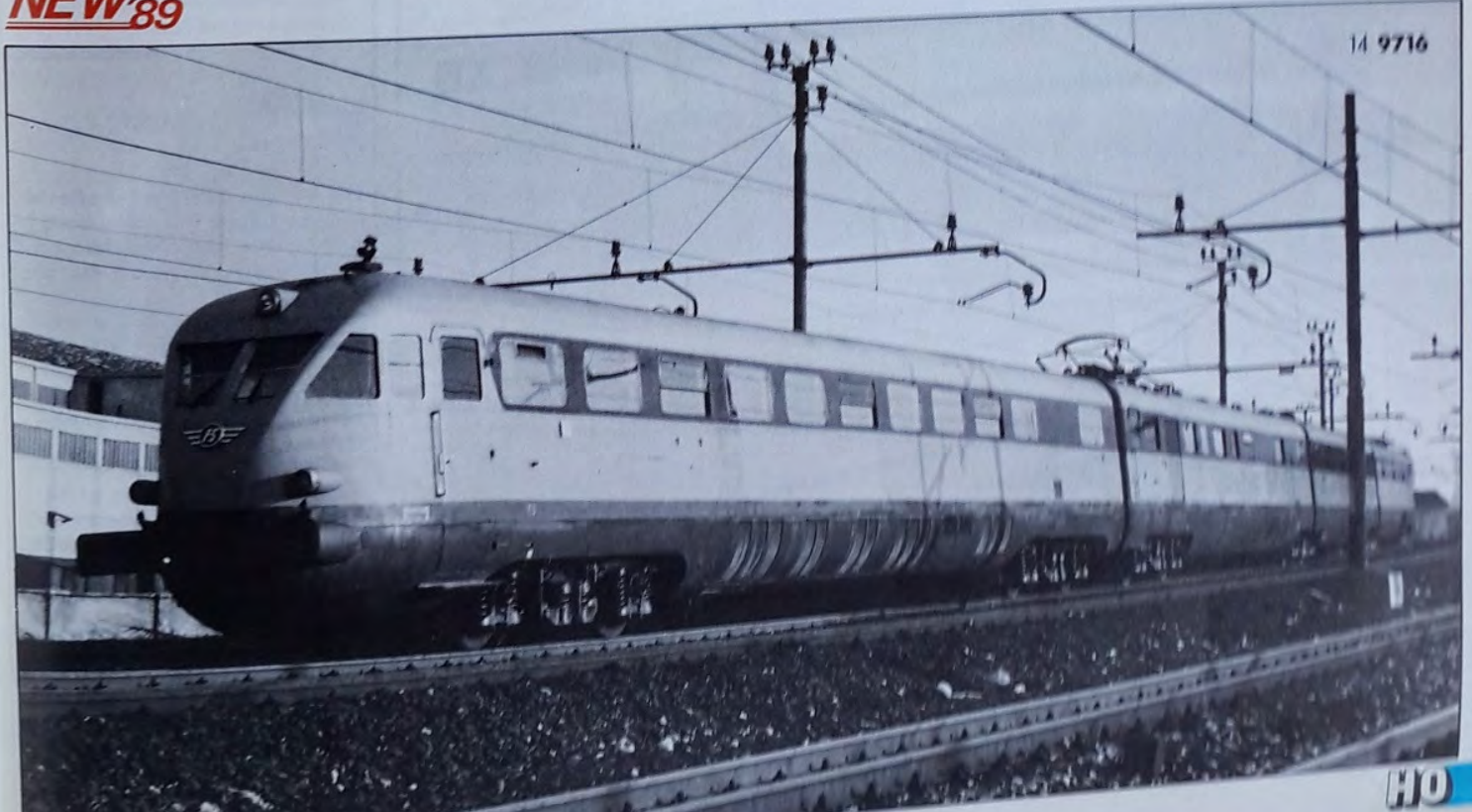

HO 11

20 8028L



20 8150L



20 8149L



20 8034L



Prima locomotiva elettrica della generazione post-bellica, la E 645 delle Ferrovie Italiane dello Stato (FS) è dotata di tre carrelli motori (tracciato Bo-Bo-Bo), sui quali poggia una cassa articolata in due parti fra loro simmetriche.

First electric locomotive of the post-war generation, the E 645 of the Italian State Railways (FS) has a distinctive Bo-Bo-Bo layout, with two body halves articulated across the centre bogie.

20 8028L

Locomotiva elettrica Gruppo E 645 della FS, nella tipica livrea castano-isabella. Lunghezza fuori respingenti mm 210. **Supertrazione.** Electric locomotive Class E 645 of FS in its original beige-brown livery. Overall length mm 210. **Supertraction.**

Derivati strettamente dal Gruppo E 645, le locomotive elettriche E 646 delle Ferrovie dello Stato Italiane (FS) sono entrate in servizio nel 1961-1967 sui percorsi veloci di misura, al traino di pesanti treni passeggeri.

Closely based on the Class E 645 units, the electric locomotives E 646 of the Italian State Railways (FS) started to work on main passenger traffic duty in 1961-1967.

20 8150L

Locomotiva elettrica E 646 della FS, livrea crema-arancio-grigio. Lunghezza fuori respingenti mm 210. **Supertrazione.** Electric locomotive Class E 646 of FS. Ivory-orange-gray livery. Overall length mm 210. **Supertraction.**

20 8149L

Locomotiva elettrica Gruppo E 644 della FS, livrea grigio-verde-rosso. Lunghezza fuori respingenti mm 210. **Supertrazione.** Electric locomotive Class E 644 of FS. Gray-green-red livery. Overall length mm 210. **Supertraction.**

Fra il 1967 e il 1974 la Ferrovie dello Stato Italiana (FS) hanno prodotto oltre cento unità della locomotiva elettrica Gruppo E 444, a tracciato Bo-Bo.

Sono dotate di 4 motori per una potenza complessiva di 5700 CV e pesano 81 tonnellate. Note per il curioso appellativo di «torpediniere» operano sulle linee veloci e nei percorsi.

The Italian State Railways (FS) produced more than 100 units of the newly-designed electric locomotive Class E 444 in the period between 1967-1974 with Bo-Bo wheel arrangement, an output of 5700 CV and an overall weight of 81 tons. Officially nicknamed "torpediniere".

20 8034L

Locomotiva elettrica Gruppo E 444 della FS, livrea grigio-azzurro-rosso. Lunghezza fuori respingenti mm 190. **Supertrazione.** Electric locomotive Class E 444 of FS. Green-blue-red livery. Overall length mm 190. **Supertraction.**

Entrate in servizio fra il 1943 e il 1951, le locomotive elettriche E 424 delle Ferrovie Italiane (FS) sono state costruite in 158 esemplari per il servizio misto leggero.

Nel 1985 è stato deciso di modificare la meccanica e la carrozzeria aumentando la velocità massima da 100 a 120 Km/h. Le locomotive E 424 200 sono utilizzate per il traino delle carrozze MDVE.

158 units of electric locomotive Class E 424 of the Italian State Railways (FS) were built between 1943 and 1951 to fulfill light traffic duties. In 1985 it was decided to modify mechanics and body increasing max. speed from 100 to 120 Kms/h. Locomotives E 424 200 are used for hauling MDVE coaches.

20 8020L

Locomotiva elettrica gruppo E 424 delle FS nella livrea per treni MDVE grigio polvere, rosso fuoco e arancio.

Supertrazione.
Electric locomotive series E 424 of Italian State Railways (FS) in its new dust-grey, fire-red and orange livery for the MDVE trains. **Supertraction.**



20 8151L

Locomotiva diesel-elettrica Gruppo D 445 delle FS, nella livrea d'origine verde-castano-isabella-rosso. Lunghezza fuori respingenti mm 162.

Supertrazione.
Diesel-electric locomotive Class D 445 of FS in its former green-brown-red livery. Overall length mm 162. **Supertraction.**



20 8152L

Locomotiva diesel-elettrica Gruppo D 445 delle FS, nella nuova livrea per treni navetta viola-arancio-grigio. Lunghezza fuori respingenti mm 162.

Supertrazione.
Diesel-electric locomotive Class D 445 of FS in its new violet-orange-grey livery. Overall length mm 162. **Supertraction.**

20 8152L



20 8064L



20 8136L



20 8168L



Ultimo stadio evolutivo della scuola italiana, le locomotive elettriche Gruppo E 656 delle Ferrovie dello Stato Italiano (FS) hanno iniziato il servizio alla fine del 1975 e sono tuttora in produzione.

La serie E 656 si aggiorna con una nuova versione (Vª serie) di 42 esemplari. Le modifiche sono elettriche e meccaniche. Nella carrozzeria gli elementi piú evoluti sono doppi fanaleria e spartineve.

Latest evolutive stage of the Italian school, the electric locomotives Class E 656 of the Italian Railways (FS) took service at the end of 1975 and are still in production.

Class E 656 comes up again with a new version (5th series) of 42 units, modifications are electrical and mechanical.

In the body double lights and snow plough stand out particularly.

20 8064L

Locomotiva elettrica Gruppo E 656 delle FS; livrea grigio-blu-rosso. Lunghezza fuori respingenti mm 210.

Supertrazione.

Electric locomotive class E 656 519 of the Italian Railways (FS); grey-blue-red livery. Overall length 210 mm. Supertraction.

Le nuove locomotive elettriche E 633 delle Ferrovie dello Stato Italiano (FS) sono entrate in servizio a cominciare dal 1980. Dotate di tre carrelli monomotori eroganti una potenza complessiva di 6670 HP e di un'unica cassa lunga quasi 18 metri.

The new electric locomotives Class 633 of the Italian State Railways (FS) were introduced from 1980.

Fitted with three monomotor bogies for a total output of 6670 HP, they feature a non-articulated body 59 feet long.

20 8136L

Locomotiva elettrica Gruppo E 633 delle FS; livrea grigio-blu-rosso. Lunghezza fuori respingenti mm 200.

Supertrazione.

Electric locomotive Class E 633 of FS. Grey-blue-red livery. Overall length mm 200. Supertraction.

È la versione più recente del locomotore E 633 delle Ferrovie dello Stato Italiane (FS). Rappresenta la seconda generazione di queste fortunate motrici polivalenti e differisce dalla prima per sensibili varianti sia meccaniche che di equipaggiamento elettrico.

It is the latest version of the electric locomotive Class 633 of the Italian State Railways (FS). It represents the second generation of this multipurpose locomotive and features significant modifications, both mechanical and electrical, if compared with the former model.

20 8146L

Locomotiva elettrica Gruppo E 633 delle FS, livrea grigio-blu-rosso. Lunghezza fuori respingenti mm 200. **Supertrazione.**

*Electric locomotive Class 633 of FS. Grey-blue-red livery. Overall length mm 200. **Supertraction.***



20 8146ACL

Modello predisposto per corrente alternata. **Supertrazione.**

*Model in AC version. **Supertraction.***

Le Ferrovie dello Stato Italiane (FS) hanno posto in servizio nel 1983 le automotrici ALn 663 per servizio locale. Dotate di due motori diesel Fiat per complessivi 310 HP, dispongono di una trasmissione meccanica con giunto idraulico. Con un peso di 35 tonnellate, possono trasportare 63 persone in 1° e 2° classe ad una velocità variabile, a seconda dei rapporti di trasmissione, fra i 110 e i 130 km/h.

The Italian State Railways (FS) put a new diesel railcar Class ALn 663 into service in 1983. Designed to operate in light passenger traffic, they are powered by two Fiat diesel engines with a total output of 310 HP and fitted with a mechanical transmission. They weigh 35 tons and can carry 63 passengers in the first and second class compartments. Top speed, according to the various transmission ratios, is 68-81 mph.



20 8146L
20 8146ACL



30 9199

20 8168L

Automotrice diesel Gruppo ALn 663 delle FS, numero progressivo 1150, con unità accoppiata simmetrica, non motorizzata (30 9196), numero progressivo 1106. Il convoglio può essere inoltre integrato dall'articolo 30 9199. **Trasmissione cardanica singola.**

*Diesel railcar Class ALn 663 1150 of FS in its grey-red-blue livery. Coupled to an identical trailer-unit (30 9196) Class ALn 663 1106, without motor. **Single joint transmission.** The train can be enlarged by additional unit 30 9199, separately available.*

30 9199

Automotrice diesel ALn 663 delle FS, numero progressivo 1015, non motorizzata. Diesel railcar Class ALn 663 1015 of FS, without motor.



Marco Polo



20 8165L

Elettromotrice del gruppo ALe 601 delle FS con unità rimorchiata Le 601 non motorizzata. **Doppia trasmissione cardanica.**

Electric locomotive of Italian State Railways (FS) series ALe 601 with 601 trailer car without engine.

Double joint transmission.

AC WS 20 8165ACL

Modello predisposto per corrente alternata. **Trasmissione cardanica singola.**

Model in AC version. Single joint transmission.

20 8165L

20 8165ACL



NEW 88

20 8195
Elettromotrice ALe 601-055 senza motore.
Locomotive ALe 601-055 without motor.



NEW 88

30 9227
Carrozza ristorante Le 480-004 delle FS.
Restaurant coach Le 480-004 of FS.

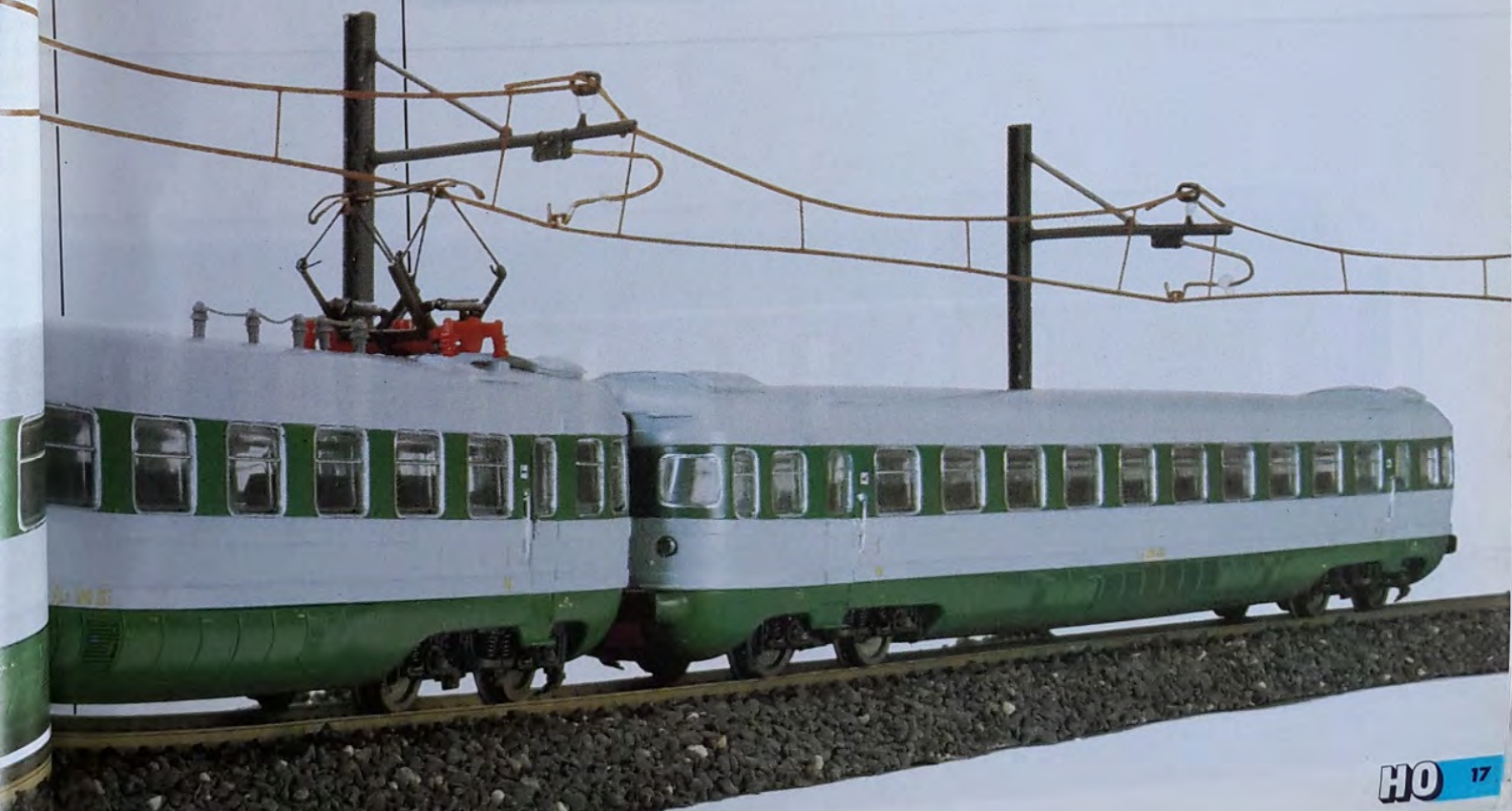

30 9228



Carrozza passeggeri di 2ª classe, a due piani, nella nuova livrea crem-arancio-grigio, delle Ferrovie Italiane (F.S.) - L. 268 mm.
 Second class, double-deck passenger coach, of the F.S., cream-orange-grey livery - Length 268 mm.

30 9229



Carrozza-pilota di 2ª classe, a due piani, nella nuova livrea crem-arancio-grigio, senza motore, delle Ferrovie Italiane (F.S.) - L. 268 mm.
 Second class, double-deck pilot coach, of the F.S., without motor, cream-orange-grey livery - Length 268 mm.



30 9133

Carrozza passeggeri a comparti di 1^a classe, tipo 7195W per convogli T.E.E. delle Ferrovie Italiane F.S. - L. 268 mm.

Passenger coach type 7195W, with 1st class compartments, for TEE Trains of the F.S. - Length 268 mm.



30 9133

30 9116

Carrozza passeggeri UIC-X tipo B a comparti di 2^a classe, nella colorazione rosso/grigio delle Ferrovie Italiane F.S. - L. 268 mm.

Passenger coach UIC-X, with 2nd class compartments, type B, in red/grey livery, of the F.S. - Length 268 mm.



30 9116

30 9315

Carrozza bagagliaio UIC-X tipo D, nella colorazione rosso/grigio delle Ferrovie Italiane F.S. - L. 255 mm.

Luggage coach UIC-X, type D, in red/grey livery, of the F.S. - Length 255 mm.

30 9115

Carrozza passeggeri UIC-X tipo A a comparti di 1^a classe, nella colorazione rosso/grigio delle Ferrovie Italiane F.S. - L. 268 mm.

Passenger coach UIC-X, with 1st class compartment, type A, in red/grey livery, of the F.S. - Length 268 mm.



30 9315

30 9115



HO 19



30 9287



30 9287

Carrozza passeggeri di 1° classe, nella più recente colorazione delle Ferrovie Italiane (F.S.), di tipo a corridoio centrale, particolarmente adatta all'impiego per treni Intercity per collegamenti su medie distanze - L. 303 mm.

Passenger coach, 1st class, for middle distances, in red/grey livery of the F.S. - Length 303 mm.

30 9288



30 9288

Carrozza passeggeri di 2° classe, nella più recente colorazione delle Ferrovie Italiane (F.S.), di tipo a corridoio centrale, particolarmente adatta all'impiego per treni Intercity per collegamenti su medie distanze - L. 303 mm.

Passenger coach, 2nd class, for middle distances, in red/grey livery of the F.S. - Length 303 mm.

30 9289L



30 9289L

Carrozza-pilota di 2° classe, nella più recente colorazione delle Ferrovie Italiane (F.S.), di tipo a corridoio centrale, particolarmente adatta all'impiego per treni Intercity e collegamenti su medie distanze. Senza motore, con illuminazione frontale - L. 303 mm.

Semidriver passenger coach, for middle distances, in red/grey livery with frontal lighting, of the F.S. - Length 303 mm.

30 9205



NEW '88

30 9205

Carrozza passeggeri MDVE «Sleeperette» delle F.S., con sedili reclinabili - L. 303 mm.

MDVE coach «Sleeperette» of the F.S. with single couchette seats - Length 303 mm.

30 9136

Carrozza passeggeri semipilota di 2° classe, a piano ribassato e vestiboli centrali, tipo npBD nella nuova colorazione delle Ferrovie Italiane F.S. - L. 268 mm.

Passenger semidriver coach 2nd class with lowered floor, central lobby, type npBD, in the new liveries of the F.S. - Length 268 mm.



30 9136

30 9271

Carrozza passeggeri di 2° classe, tipo nB, a vestiboli centrali per Medie Distanze nella nuova colorazione delle Ferrovie Italiane F.S. - L. 303 mm.

Passenger coach, 2nd class, type nB, with central lobbies, for middle distances, in the new liveries of the F.S. - Length 303 mm.



30 9271

30 9273

Carrozza passeggeri semipilota di 2° classe, tipo npBD, a vestiboli centrali per Medie Distanze nella nuova colorazione delle Ferrovie Italiane F.S. - L. 303 mm.

Passenger coach, 2nd class, semidriver, type npBD, with central lobbies, for middle distances, in the new liveries of the F.S. - Length 303 mm.



30 9273

30 9275L

Carrozza passeggeri semipilota di 2° classe, tipo npBD, a vestiboli centrali per Medie Distanze (senza intercomunicante) nella nuova colorazione delle Ferrovie Italiane F.S. con illuminazione frontale - L. 303 mm.

Semidriver passenger coach, 2nd class, type npBD, with central lobbies, for middle distances, with frontal lighting, (without vestibule) in the new livery of the F.S. - Length 303 mm.

30 9275L





14 9711
TGV TRICORRENTE
«NEUCHATEL»

Confezione «Golden Series» contenente un elettrotreno TGV delle SNCF nell'originale livrea arancio-bianco-grigio; composto di quattro elementi:

- 20 **1095L** - motrice di testa tipo M1. **Alta velocità**
- 20 **1096** - rimorchiata mista, 1° classe/bagagliaio R1
- 20 **1098** - rimorchiata mista, 2° classe/ristorante R8
- 20 **1099** - motrice di coda tipo M2, senza motore.

Il convoglio può essere inoltre integrato da uno o più elementi:

- 20 **1094**, 20 **1097**, 20 **1100**, acquistabili separatamente.

TGV THREE-CURRENT
«NEUCHATEL»

"Golden Series" set of an electric TGV train of SNCF in its original orange-white-grey livery. Formed by four units:

- 20 **1095L** - powered front-end car Class M1. **High speed**
- 20 **1096** - composite-luggage/first class coach
- 20 **1098** - restaurant/second class coach
- 20 **1099** - dummy rear-end car Class M2, without motor.

The train can also be enlarged by one or more additional units, available separately: 20 1094, 20 1097 and 20 1100.

AC 14 9711AC

WS Modello predisposto per il funzionamento in corrente alternata. **Alta velocità.**

Model in AC version. High speed.

14 9710
TGV «LA POSTE»

Confezione «Golden Series» contenente un elettrotreno TGV «LA POSTE» delle S.N.C.F., composto di quattro elementi:

- 20 **1105L** - motrice di testa. **Alta velocità**
- 20 **1106** - rimorchiata
- 20 **1108** - rimorchiata
- 20 **1109** - motrice di coda, senza motore.

Il convoglio può essere integrato da uno o più elementi centrali:

- 20 **1104**, acquistabili separatamente.

TGV «LA POSTE»

"Golden Series" set of an electric TGV "La Poste" train of SNCF, formed by four units:

- 20 **1105L** - powered front-end car. **High speed**
- 20 **1106** - coach
- 20 **1108** - coach
- 20 **1109** - dummy rear-end car, without motor.

The train can be enlarged by one or more additional units 20 1104, separately available.





20 1094 - Rimorchiata intermedia TGV di 2° classe, R5-R6-R7.
Second class TGV coach of SNCF.



20 1097 - Rimorchiata intermedia TGV mista, 2° classe/bar, R4.
Bar/second class TGV coach of SNCF.

20 1100 - Rimorchiata intermedia TGV di 1° classe, R2-R3. First
class TGV coach of SNCF.

Nel 1984 sono stati messi in servizio 2 convogli TGV «La Poste». Hanno le stesse caratteristiche generali dei convogli TGV-PSE delle ferrovie francesi. Sono stati tuttavia adattati al trasporto della posta tra Parigi e Lione con contenitori.

Two convoys TGV "La Poste" were introduced in 1984. They have the same general features of the French convoys TGV-PSE but they are only transporting mail in containers from Paris to Lyon.



20 1104
Rimorchio intermediario TGV «La Poste». Vi permette di completare il vostro TGV Postale (ref. 14 9710) che ne comprende 6 nella sua composizione completa.
Central coach TGV "La Poste" to complete your Post TGV (ref. 14 9710) whose convoy is of six elements.

NEW



14 9714

Confezione "Golden Series" contenente un elettrotreno nell'originale livrea blue-grigio, composto di quattro elementi:

20 1085L - motrice di testa tipo M1.

Alta velocità

20 1086 - rimorchiata mista, 1° classe/bagagliaio R1

20 1088 - rimorchiata mista, 2° classe/ristorante R8

20 1089 - motrice di coda tipo M2, senza motore.

Il convoglio può essere inoltre integrato da uno o più elementi:

20 1083, 20 1084, 20 1087, acquistabili separatamente.

"Golden Series" set of an electric train in its original blue-grey livery.

Formed by four units:

20 1085L - powered front-end car class M1. **High speed**

20 1086 - composite-luggage/first class coach

20 1088 - restaurant/second class coach

20 1089 - dummy rear-end car, class M2, without motor.

The train can also be enlarged by one or more additional units, available separately: 20 1083, 20 1084 and 20 1087.

NEW

20 1087 - Rimorchiata intermedia mista 2° classe/bar R4. Bar/second class coach.

20 1084 - Rimorchiata intermedia 2° classe R5-R6-R7. Second class coach.

20 1083 - Rimorchiata intermedia 1° classe R2-R3. First class coach.



20 1087



NEW

20 1084



NEW

20 1083



14 9814

**CONVOGLIO
PENDOLARE R.I.B.**

Confezione «Golden Series» contenente un convoglio passeggeri della SNCF, composto di quattro elementi:
20 **8181501** - locomotiva diesel BB 67382. **Doppia trasmissione cardanica**

30 **9276** - carrozza d'estremità di 1°/2° classe; colorazione inox

30 **9277S** - carrozza di 2° classe; colorazione inox

30 **9278L** - carrozza-pilota di 2° classe; colorazione inox.

Il convoglio può essere integrato separatamente da uno o più elementi centrali: 30 **9277** acquistabili separatamente.

R.I.B. COMMUTING TRAIN

"Golden Series" set of an electric suburban train of SNCF, consisting of four units:

20 **208181501** - diesel locomotive class BB 67382

Double joint transmission

30 **9276** - first/second class front-end coach; inox steel construction

30 **9277S** - second class coach; inox steel construction

30 **9278L** - second class rear-end pilot-coach; inox steel construction.

The train can be enlarged by one or more additional units 30 **9277**, separately available.

NEW⁸⁸



14 9726

RIO «METRALSACE»

Confezione «Golden Series» contenente un treno della SNCF composto da tre elementi:

30 **9276S03** - carrozza d'estremità di 1° e 2° classe

30 **9277S03** - carrozza di 2° classe

30 **9278LS3** - carrozza-pilota di 2° classe con luce.

RIO "METRALSACE"

"Golden Series" set of a train of SNCF formed by three units:

30 **9276S03** - first/second class front-end coach

30 **9277S03** - second class coach

30 **9278LS3** - second class rear-end pilot coach; with light.





30 9277

Carrozza passeggeri del convoglio R.I.B. di 2° classe delle S.N.C.F.
Second class coach of S.N.C.F.; inox steel construction.





NEW₈₈

14 9727

RIB

Confezione "Golden Series" contenente un treno della SNCF composto da tre elementi:

30 9276 - carrozza d'estremità di 1° e 2° classe

30 9277 - carrozza di 2° classe

30 9278L - carrozza-pilota di 2° classe con luce.

RIB

"Golden Series" set of a train of SNCF formed by three units:

30 9276 - first/second class front-end coach

30 9277 - second class coach

30 9278L - second class rear-end pilot-coach, with light.





14 9819

RIO «PROVENCE-ALPES-CÔTE D'AZUR»

Confezione «Golden Series» contenente un elettrotreno della SNCF composto da quattro elementi:

- 20 **8172501** - locomotiva elettrica bicorrente BB25522 nella nuova livrea grigia e arancione. **Doppia trasmissione cardanica**
- 30 **9276501** - carrozza d'estremità di 1° e 2° classe
- 30 **9277501** - carrozza di 2° classe
- 30 **9278LS1** - carrozza pilota di 2° classe con luce.

RIO "PROVENCE-ALPES-CÔTE D'AZUR"

"Golden Series" set of an electric train of SNCF. Formed by four units:

- 20 **8172501** - electric locomotive class BB25522 in its new grey-orange livery. **Double joint transmission.**
- 30 **9276501** - first/second class front-end coach
- 30 **9277501** - second class coach
- 30 **9278LS1** - second class rear-end pilot-coach, with light.



 FEDERATION FRANCAISE DE MODELISME FERROVIAIRE

MODELE DE L'ANNEE
 1988-1989

LIMA





NEW₈₈

14 9821K

CORAIL

Confezione «Golden Series» contenente un treno Corail composto da quattro elementi:

20 **8176S01** - locomotiva serie BB8612 delle SNCF, livrea grigio-arancione con nuovo marchio SNCF.

Doppia trasmissione cardanica

30 **9232K** - carrozza Corail di 1° classe A10tu con porte scorrevoli

30 **9193K** - carrozza Corail di 2° classe B11tu con porte scorrevoli

30 **9200K** - carrozza Corail mista 1°/2° classe A5B5tu con porte scorrevoli.

CORAIL

"Golden Series" set of a Corail train of SNCF. Formed by four units:

20 **8176S01** - locomotive BB8612 of SNCF, in the grey-orange livery with new SNCF mark. **Double joint transmission.**

30 **9232K** - first class Corail coach A10tu with sliding doors

30 **9193K** - second class Corail coach B11tu with sliding doors

30 **9200K** - mixed 1st/2nd class Corail coach A5B5tu with sliding doors.





14 9818

DEV

Confezione «Golden Series» contenente un elettrotreno della SNCF composto da quattro elementi:
 20 **8181502** - locomotiva diesel-elettrica serie BB67344 delle SNCF, livrea azzurro-bianco. **Doppia trasmissione cardanica**

30 **9103** - carrozza DEV 1° classe A8 con nuovo marchio SNCF

30 **9104** - carrozza DEV 2° classe B8 con nuovo marchio SNCF

30 **9209** - carrozza DEV con cuccette di 2° classe B9 C9 con nuovo marchio SNCF.

DEV

“Golden Series” set of a diesel-electric train of SNCF. Formed by four units:

20 **8181502** - diesel-electric locomotive class BB67344 of SNCF in light blue-white livery. **Double joint transmission**

30 **9103** - first class DEV coach A8 with new SNCF mark

30 **9104** - second class DEV coach B8 with new SNCF mark

30 **9209** - second class sleeping coach DEV with new SNCF mark.

Le Ferrovie dello Stato Francesi (SNCF) hanno posto in servizio delle nuove vetture Corail con porte scorrevoli. La LIMA ha realizzato 3 modelli: 1° classe, 2° classe e mista di 1° e 2° classe. Esse formano un convoglio molto omogeneo con la locomotiva elettrica BB8500 nella livrea grigio-arancio con nuovo marchio SNCF.

The Corail coaches, a very large family that LIMA wants to execute completely. Here there are three models (1st class, 2nd class and 1st/2nd class mixed) equipped with sliding doors and new SNCF mark.

They form a very harmonious convoy with the grey BB 8500 locomotive in the new French livery.



NEW 88

20 8173L



Le SNCF hanno messo in servizio dal 1985 una nuova serie di automotrici, le X2200, che, con una potenza di 440 KW, possono raggiungere una velocità di 140 Km/h.
In 1985 the French State Railways put into service a new series of railcars X2200. 440 KW powered they can reach a speed of 140 Km/h.

«AUVERGNE»

20 8174L

Automotrice X2202 in livrea blu «Auvergne» e rimorchiata XR6096 delle SNCF. **Trasmissione cardanica singola.**

Railcar X2202 in blu livery "Auvergne" and trailer car XR6096 of French State Railways (SNCF). Single joint transmission.

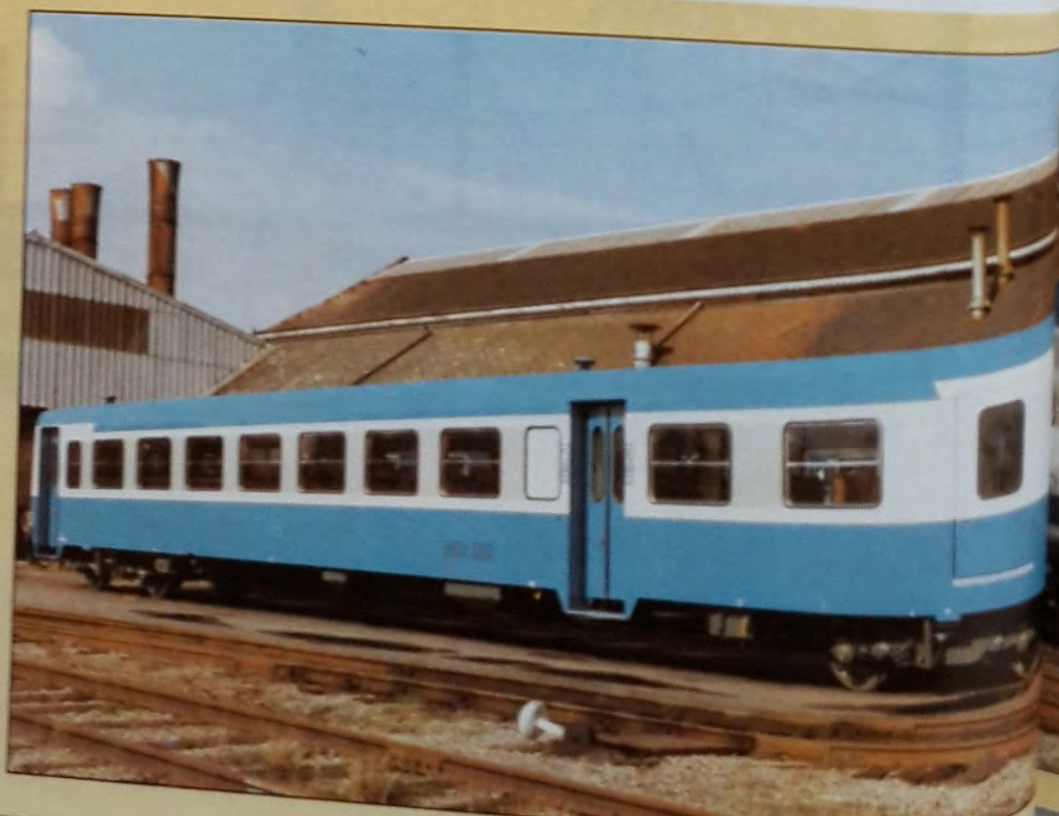



AUTOMOTRICI SERIE X2200

RAILCAR CLASS X2200

20 8173L

SNCF
Automotrice X2212 e rimorchiata XR6108 nella livrea rossa delle SNCF. *Trasmissione cardanica singola.*
Railcar X2212 and trailer car XR6108 in the red livery of French State Railways (SNCF). *Single joint transmission.*



20 8174L

NEW'88

«NORMANDIE»

20 8196L

Automotrice X92201 e rimorchiata XR96005 in livrea verde «Normandie». **Trasmissione cardanica singola.**

Railcar X92201 and trailer car XR96005 in "Normandie" green livery. Single cardan transmission.



NEW'88

«MIDI-PYRENEES»

20 8197L

Automotrice X92202 e rimorchiata XR96006 in livrea EPR «Midi-Pyrenees». **Trasmissione cardanica singola.**

Railcar X92202 and trailer car XR96006 in EPR "Midi-Pyrenees" livery. Single cardan transmission.



NEW'88

«LANGUEDOC-ROUSSILLON»

20 8198L

Automotrice X92203 con i colori dell'«EPR Languedoc-Roussillon» e rimorchiata XR6090 delle SNCF. **Trasmissione cardanica singola.**

Railcar X92203 in "EPR Languedoc-Roussillon" livery and trailer car XR6090 of French State Railways (SNCF). Single cardan transmission.



AUTOMOTRICI SERIE X2200

RAILCAR CLASS X2200





20 8161L



20 8161L

NEW₈₈



20 8169L

20 8169L

Locomotiva elettrica serie CC delle SNCF; colore blu. Doppia trasmissione cardanica. Electric locomotive class CC of SNCF, in its blue livery. Double joint transmission.

20 8170L

Locomotiva elettrica serie CC delle SNCF; colore verde. Doppia trasmissione cardanica. Electric locomotive Class CC of SNCF, green-livery. Double transmission.

20 8170L



20 8161L

Locomotiva bicorrente BB26000 delle SNCF, nella nuova livrea arancio-bianco-grigia. Sviluppa una potenza di 5600 KW per una velocità massima in servizio di 200 Km/h. **Doppia trasmissione cardanica.**

Electric locomotive class BB26000 of SNCF, in new orange-white-grey livery. With a weight of 90 tons, it develops a power of 5600 KW for a maximum speed of 200 Km/h.

Double joint transmission.

20 8181L

Locomotiva diesel-elettrica serie BB67302 delle SNCF; livrea azzurro-bianco. Lunghezza fuori respingenti mm 195. **Doppia trasmissione cardanica.**

Diesel-electric locomotive class BB67302 of SNCF in its original light blue-white livery. Overall length mm 195. **Double joint transmission.**

20 8036L

Locomotiva diesel-elettrica serie BB67302 delle SNCF; livrea azzurro-bianco. Lunghezza fuori respingenti mm 195. **Supertrazione.**

Diesel-electric locomotive Class BB67302 of SNCF in its original light blue-white livery. Overall length mm 195. **Supertraction.**

20 8181L



NEW₈₈





...are per
vizio veloce sulla linea della
Azzurra, le locomotive BB2200
corrente delle Ferrovie dello S
Francesi (SNCF) sono entrate
vizio nel dicembre 1977. Svilu
una potenza di 5200 HP, che
sente loro una velocità in serv
160 km/h, con punte fino a 18
km/h.
Especially designed for the fa
way traffic on the Côte d'Azur
routes, the dual-voltage locom
Class 22000 of the French Sta
Railways (SNCF) started to wo
December 1977. They develop
tal output of 5200 HP, which
ables them to run at 100 mph
peaks up to 112 mph.

20 8111L

Locomotiva elettrica serie BB22000 delle SNCF, livrea grigio-arancio. Lunghezza fuori respingenti mm 200. **Supertrazione.**
Electric locomotive Class BB22000 of SNCF. Grey-orange livery. Overall length mm 200. **Supertraction.**

20 8127L



Una delle più famose serie di locomotive elettriche delle Ferrovie dello Stato Francesi (SNCF) è senz'altro la BB9200, in servizio dal 1956 e usata fino ai giorni nostri dopo aver stata in testa ai più prestigiosi treni passeggeri francesi. Le BB9200 hanno recentemente subito alcuni aggiornamenti tecnici e hanno pure assunto le nuove livree a colori vivaci introdotte dalle SNCF.

One of the most famous series of electric locomotive of French State Railways (SNCF) is with no doubt the BB9200, introduced in 1956 and still in operation after having worked as hauliers of the most prestigious French trains. The BB9200 were recently updated in their electrical equipment and as being painted in the brand-new liveries introduced by SNCF.

20 8171L



Locomotiva elettrica serie BB9200 delle SNCF, livrea grigio chiaro / grigio scuro e arancio. Lunghezza fuori respingenti mm 185. **Supertrazione.**
Electric locomotive Class BB9200 of SNCF. Light - dark grey / orange livery. Overall length mm 185. **Supertraction.**

20 8171L

Locomotiva elettrica bicorrente BB25503 nella livrea originale verde e bianca delle SNCF. **Doppia trasmissione cardanica.**
Electric locomotive class BB25503 in its original green-white livery of SNCF. **Double joint transmission.**

20 8172L



20 8172L

Locomotiva elettrica bicorrente BB25525 nella nuova livrea grigio-arancio delle SNCF. **Doppia trasmissione cardanica.**

in servizio dal 1961 fino al 1974. Questa serie di 145 locomotive (BB8501 fino a 8646) è divisa in più sottoserie. I modelli riprodotti fanno parte dell'ultima sottoserie che comprende le BB8588 fino a 8646 cosiddette «lunghe» o «a persiane inox». Percorrono le linee elettrificate a corrente continua 1500 V delle reti Ovest, Sud-Ovest e Sud-Est della S.N.C.F.

The locomotives class BB8500 of the SNCF in operation from 1961 to 1974.

This series of 146 locomotives (BB8501 up to 8646) is divided into four sub-series.

The models we have reproduced belong to the last sub-series including the BB8588 up to the 8646 also called "long" or "stainless gratings". They operate in direct current at 1500 V on the electrified lines of the West, South-West and South-East French Railway System.

20 8175L

Locomotiva elettrica BB8595 nel colore originale verde. **Doppia trasmissione cardanica.**

*Electric locomotive Class BB8595 in its original green livery. **Double joint transmission.***

20 8176L

Locomotiva elettrica BB8596 nei nuovi colori grigio-arancio. **Doppia trasmissione cardanica.**

*Electric locomotive Class BB8596 in its new grey-orange livery. **Double joint transmission.***



20 8166L



20 8166L

Locomotiva elettrica serie BB9200 delle SNCF, livrea d'origine. Lunghezza fuori respingenti mm 185. **Supertrazione.** Electric locomotive Class BB9200 SNCF. Original green-white livery. Overall length mm 185. **Supertration.**

20 8159L



20 8159L

Locomotiva elettrica serie BB9500 (tipo BB9522) delle SNCF, livrea nuova. Lunghezza fuori respingenti mm 185. **Supertrazione.** Electric locomotive Class BB9500 (type BB9522) of SNCF. New grey-yellow livery. Overall length mm 185. **Supertration.**

20 8160L

Locomotiva elettrica serie BB9400 (tipo BB9433) delle SNCF, nuova livrea grigio chiaro - grigio scuro - giallo. Lunghezza fuori respingenti mm 185. **Supertrazione.** Electric locomotive Class BB9400 (type BB9433) of SNCF. New light grey - dark grey - yellow livery. Overall length mm 185. **Supertration.**



20 8160L



Décoration d'origine de la SNCF

30 9160

Vettura cuccette DEV B²C² nella livrea originale - L. 270 mm.
 Sleeping coach DEV B²C² in original livery - Length 270 mm.



30 9160

NEW '88

30 9123

Carrozza mista di 1° e 2° classe, A3B5 nella livrea originale - L. 270 mm.
 1st/2nd class mixed coach A3B5, original livery - Length 270 mm.



30 9123

30 9148

Carrozza passeggeri a compartimenti di 1° classe DEV A⁸ nei colori d'origine SNCF - L. 270 mm.
 Passenger coach with 1st class compartments DEV A⁸ in French State Railways (SNCF) original livery - Length 270 mm.



30 9148

30 9149

Carrozza passeggeri a comparti di 2° classe DEV tipo B⁸ nei colori d'origine delle SNCF - L. 270 mm.
 Passenger coach with 2nd class compartments, type DEV B⁸, in original French State Railways (SNCF) livery - Length 270 mm.



30 9149



30 9184K



NEW '88

30 9184K

Vettura Corail 1° Classe A10tu, nuovo marchio SNCF.
1st class Corail coach A10tu, new inscriptions.

30 9185K



NEW '88

30 9185K

Vettura Corail 2° Classe B11tu, nuovo marchio SNCF.
2nd class Corail coach B11tu, new inscriptions.

30 9186K



NEW '88

30 9186K

Vettura Corail mista 2° Classe B5rtux nuovo marchio SNCF.
Mixed 2nd class/bar Corail coach B5rtux, new inscriptions.

30 9218K



NEW '88

30 9218K

Vettura Corail 2° Classe B11tu in livrea arancione «C1».
2nd class Corail coach B11tu in orange «C1» livery.

30 9234K



NEW '88

30 9234K

Vettura tipo Corail 2° Classe B11tu nella livrea regionale «Midi-Pyrénées».
2nd class Corail coach B11tu in regional «Midi-Pyrénées» livery.

30 9105K

Vettura tipo Corail 1° Classe A10tu nella livrea regionale «Midi-Pyrénées».

NEW '88

30 9266LK

Vettura Corail mista 2° Classe/pilota B6Dux nuovo marchio SNCF.
Mixed 2nd class/pilot Corail coach B6Dux, new inscriptions.



30 9266LK

30 9193K

Vettura Corail 2° Classe B11tu con porte scorrevoli.
2nd class Corail coach B11tu with sliding-doors.



NEW '88

30 9193K

30 9232K

Vettura Corail 1° Classe A10tu con porte scorrevoli.
1st class Corail coach A10tu with sliding-doors.

30 9200K

Vettura Corail mista 1°/2° Classe ASB5tu a porte scorrevoli.
Mixed 1st/2nd class Corail coach ASB5tu with sliding-doors.

NEW '88

NEW '88



30 9232K



30 9200K

30 9104

NEW⁸⁸



30 9104

Vettura DEV 2^a Classe B8,
marchio SNCF.
2nd class DEV coach B8,
inscriptions.

30 9103

NEW⁸⁸



30 9103

Vettura DEV 1^a Classe A8,
marchio SNCF.
1st class DEV coach A8,
inscriptions.

30 9209

NEW⁸⁸



30 9209

Vettura DEV cuccette 2^a Classe
B9C9 nuovo marchio SNCF.
Sleeping coach 2nd class DE
B9C9, new inscriptions.



30 9267

Carrozza ristorante «Gril Express», nella colorazione bianco-grigio-arancio, del treno Corail delle Ferrovie Francesi (S.N.C.F.) - L. 268 mm. "Gril Express" restaurant coach Corail of SNCF. White-grey-orange livery - Length 268 mm.



30 9267

30 9387

Bagagliaio Corail, nella colorazione bianco-grigio-arancio, serie Dd2 delle Ferrovie Francesi (S.N.C.F.) - L. 212 mm. Luggage car Corail Class Dd2 of SNCF. White-grey-orange livery - Length 212 mm.



30 9387

30 9341

Carrozza bagagliaio, tipo Dd2, nella colorazione verde/grigio delle Ferrovie Francesi S.N.C.F. - L. 211 mm. Luggage coach, type Dd2, for international trains, of the S.N.C.F. Green-grey livery - Length 211 mm.



30 9341

30 9350

Carrozza postale tipo PA, nella nuova colorazione, delle Ferrovie Francesi S.N.C.F. - L. 268 mm. Postal wagon, type PA, of the S.N.C.F. New livery - Length 268 mm.

30 9350



14 9747

Serie 800

Confezione «Golden Series» contenente un elettrotreno serie 800 delle SNCB nella livrea bianco-rossa; composta di 4 elementi:

20 10155 - carrozza-pilota di 2^a classe, senza motore

20 10165 - carrozza centrale motrice di 2^a classe. **Alta velocità**

20 10175 - carrozza centrale di 2^a classe

20 10185 - carrozza-pilota di 2^a classe, senza motore.

Class 800

"Golden Series" set of an electric Intercity train class 800 of SNCB in white-red livery. Formed by four units:

20 10155 - second class front-end coach, without motor

20 10165 - second class powered coach. **High speed**

20 10175 - second class coach

20 10185 - dummy second class rear-end coach, without motor.



NEW '88

20 8023L



Le più recenti locomotive elettriche tricorrente delle Ferrovie dello Stato Belge (SNCB) appartengono alla serie 27, prodotte dalla Brugeoise et Nivelles negli anni 1981-83. Hanno rodiggio Bo-Bo e sviluppano quattro assi motori una potenza complessiva di 5780 HP. Con un peso in servizio di 85 tonnellate, possono trainare un pesante treno passeggeri a 160 km/h. Ne sono attualmente in servizio 60 unità.

The most recent three-voltage electric locomotives of the Belgian State Railways (SNCB) belong to the Class 27, built by Brugeoise and Nivelles in 1981-1983. They were designed on a Bo-Bo layout, with four motored axles powered by 5780 HP. The total weight is 85 tons.

These locomotives are capable of 100 mph at the head of heavy passenger trains. 60 units are currently on duty.

20 8023L

Locomotiva elettrica serie 27 della SNCB, livrea blu-gialla. Lunghezza fuori respingenti mm 210. **Supertrazione.**

Electric locomotive Class 27 of SNCB. Blue-yellow livery. Overall length 210 mm. **Supertraction.**

Gli elettrotreni veloci 800 per servizio pendolare delle Ferrovie dello Stato Belge (SNCB) sono entrati in servizio nel 1975. Si compongono di quattro elementi di cui i due centrali motori, per una potenza complessiva di 2040 HP. L'intero convoglio pesa 216 tonnellate e può trasportare 500 passeggeri di 2° classe, dei quali 358 seduti. La lunghezza complessiva è di 99 metri. Velocità 140 Km/h.

The fast multiple-unit electric trains Class 800 of the Belgian State Railways (SNCB) have been developed for commuting purposes and were introduced in 1975. They consist of four units, the two middle ones being powered for a total output of 2040 HP. The whole set of four units weighs 216 tons and can carry 500 second class passengers (358 seated) at 87 mph. The overall length is 325 feet.



La serie CC40100 è stata realizzata espressamente dalle Ferrovie dello Stato Francesi (SNCF) per il traino dei convogli Trans Europ Express. Con alcune varianti, sei di queste locomotive sono entrate in servizio anche in Belgio a partire dal 1974, costruite dalla Alsthom e immatricolate come classe 18 delle Ferrovie dello Stato belghe (SNCB), per il servizio sulla Bruxelles-Parigi e sulla Bruxelles-Colonia.

Apart from slight changes, six units of quadri-voltage electric locomotives class CC40100 of SNCF were delivered by Alsthom to the Belgian State Railways since 1974 and they joined the SNCB motive stock as Class 18.

20 8121L

Locomotiva elettrica serie 18 delle Ferrovie di Stato belghe (SNCB). Lunghezza fuori respingenti mm 255. **Supertrazione.**

Electric locomotive Class 18 of SNCB. Overall length mm 255. Supertraction.



20 8121L

20 8027L

Locomotiva elettrica serie 150 delle SNCB; livrea blu-nero. Lunghezza fuori respingenti mm 200. **Supertrazione.**

Electric locomotive Class 150 of SNCB in its blue-black livery. Overall length mm 200. Supertraction.



20 8027L

20 8182L



20 8182L

Locomotiva elettrica serie 125 della SNCB. Lunghezza fuori respingenti mm 200. **Supertrazione.**
Electric locomotive class 125 of SNCB. Overall length mm 200. **Supertraction.**

20 8185L



NEW 88

20 8185L

Locomotiva elettrica serie 125 della SNCB in livrea verde originale. Lunghezza fuori respingenti mm 200. **Supertrazione.**
Electric locomotive class 125 of SNCB in the original green livery. Length mm 200. **Supertraction.**

30 1023



30 1023

Carrozza passeggeri di 1° classe nella caratteristica colorazione acciaio-rosso, per convogli T.E.E. della SNCB - L. 268 mm.
Passenger coach, 1st class, in red inox steel livery, of the SNCB - Length 268 mm.

30 9134

Carrozza passeggeri di 1° classe delle Ferrovie Belghe S.N.C.B. - L. 278 mm.

Passenger coach, 1st class, SNCB - Length 278 mm.



30 9134

30 9132

Carrozza passeggeri di 2° classe delle ferrovie Belghe S.N.C.B. - L. 278 mm.

Passenger coach, 2nd class, S.N.C.B. - Length 278 mm.



30 9132

30 9108

Carrozza passeggeri mista di 1° e 2° classe delle Ferrovie Belghe S.N.C.B., serie 43291 - L. 253 mm.

Composite passenger coach 1st and 2nd class, series 43291, of the S.N.C.B. - Length 253 mm.



30 9108

30 9303

Carrozza passeggeri di 2° classe con bagagliaio delle Ferrovie Belghe S.N.C.B., serie 49253 - L. 253 mm.

Composite coach, 2nd class passenger/luggage, series 49253, of the S.N.C.B. - Length 253 mm.



30 9303

30 1033

Carrozza passeggeri di 2° classe nella caratteristica colorazione inox per convogli T.E.E. delle SNCB - L. 268 mm.

Passenger coach 2nd class, inox steel livery of the SNCB - Length 268 mm.



30 1033



**14 9812
TEE GOTTARDO**

Confezione «Golden Series» contenente elettrotreno RAe TEE II delle SBB, nella caratteristica livrea rosso-crema; composto di quattro elementi:

- 20 **1004L** - carrozza-pilota di 1° classe
- 20 **1007** - carrozza centrale di 1° classe
- 20 **1008** - carrozza motrice. **Doppia trasmissione cardanica.**
- 20 **1009L** - carrozza-pilota di 1° classe, con luci di coda.

Il convoglio può essere integrato da altri due elementi centrali: 20 **1005** e 20 **1006**, acquistabili separatamente.

TEE GOTTARDO

"Golden Series" set of an electric train class RAe TEE II of SBB, in its original ivory-red livery. Consisting of four units:

- 20 **1004L** - first class leading coach
- 20 **1007** - first class coach
- 20 **1008** - powered coach. **Double joint transmission**
- 20 **1009L** - dummy first class rear-coach, with rear light.

The train can be enlarged by two additional units, separately available: 20 **1005** and 20 **1006**.

14 9812AC

Modello predisposto per funzionamento a corrente alternata. **Trasmissione cardanica singola.**

Model in AC version. **Singole joint transmission.**

Gli elettrotreni policorrente RAe TEE II delle Ferrovie Federali Svizzere (SBB) sono entrati in servizio fra il 1961 e il 1967 su alcuni grandi percorsi internazionali serviti dai treni Trans Europ Express, ad esempio sulla linea Parigi-Losanna-Milano e sulla Zurigo-Bruxelles. Composto di sei elementi, ogni convoglio è lungo quasi 150 metri, sviluppa una potenza di 3143 HP, pesa 296 tonnellate e può raggiungere i 160 km/h.



20 **1006** - Carrozza di 1° classe ristorante. *First class restaurant coach.*



20 **1005** - Carrozza di 1° classe. *First class coach.*

The RAe TEE II electric multi-voltage train of Swiss Federal Railways (SBB) was introduced in 1961-1967 on some of the main international lines served by Trans Europ Express; for example on the Paris-Lausanne-Milan and on the Zurich-Brussels routes. This six coach-train has an overall length of about 492 feet, an output of 3143 HP and can attain a top speed of 100 mph.



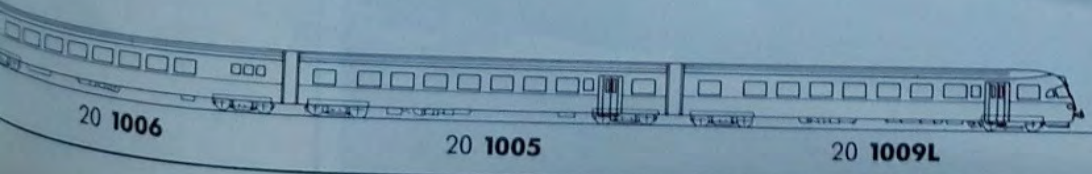



Locomotiva elettrica serie
delle SBB nella livrea
«tenz» N. 11635. Doppia
sione cardanica.
Electric locomotive class
SBB in its green livery
No. 11635. **Double**
mission.



20 8183L
20 8183ACL

20 8183L

Locomotiva elettrica serie
delle SBB nella livrea verde
N. 11605. **Doppia trasmissione cardanica.**

*Electric locomotive class Re
SBB in its green livery "Ute
11605. **Double joint trans-**
sion.*

AC 20 8183ACL
WS Modello predisposto
zionamento in corrente
nata. **Trasmissione cardanica
singola.**

*Model in AC version. **Single
transmission.***



20 8184L

20 8184L

Locomotiva elettrica serie
delle SBB nella livrea rossa
«boz» N. 11637. **Doppia trasmissione cardanica.**

*Electric locomotive class Re
SBB in its red livery "Sanc
11637. **Double joint trans-**
sion.*

20 8199L

Locomotiva elettrica serie Re 6/6^a delle SBB nella livrea verde «Interlaken» N. 11629. **Doppia trasmissione cardanica.**
*Electric locomotive class Re 6/6^a of SBB in its green livery "Interlaken" No. 11629. **Double joint transmission.***

20 8199L





20 8067L



20 8147L



20 8031L



nel 1950 locomotive el...
struzione leggera ma po...
dimensioni compatte per...
convogli passeggeri e tras...
accidentate. Con rodiggio...
(due carrelli a due assi...
una potenza complessiva...
HP, pesavano 57 tonnell...
zio e potevano raggiunge...
cità massima di 125 km/h...
in 24 unità nel 1950-51),...
immatricolate nel parco...
delle SBB come serie Re 4/4...
Since 1950 the Swiss Feder...
ways (SBB) introduced light...
and powerful electric loco...
haul both passenger and fr...
trains on moderately sloped...
As total adhesion machines...
wheel arrangement), develo...
total output of 2520 HP and...
overall weight of 57 tons, th...
comotives can attain a top...
78 mph. 24 units were bui...
1951 and were incorporat...
Class Re 4/4".

20 8066L

Locomotiva elettrica serie Re...
delle SBB, livrea d'origine ver...
gio. Lunghezza fuori resping...
170. **Supertrazione.**
Electric locomotive Class Re 4/4...
SBB in its original green-grey...
Overall length mm 170. **Super...
tration.**

20 8067L

Locomotiva elettrica serie Re...
delle SBB, nella livrea rossa...
ghezza fuori respingenti mm...
Supertrazione.
Electric locomotive Class Re 4/4...
SBB in red livery. Overall leng...
170. **Supertraction.**

Le locomotive elettriche della s...
Ae 6/6" delle Ferrovie Federali...
zere (SBB) sono entrate in serv...
nel periodo 1958-1966. Hanno...
rodiggio Co-Co, dispongono di 6...
motori per una potenza compless...
di 5830 HP e pesano in servizio...
tonnellate. La velocità massima...
125 km/h. Sono spesso impiegate...
doppia trazione sulle linee di...
fortemente accidentate.
The electric locomotives Class...
6/6" of the Swiss Federal Rail...
(SBB) were introduced in 1958-...
They have two six-wheel motor...
bogies (wheel arrangement Co...
with a total output of 5830 HP...
weigh 120 tons. Top speed is 78...
mph. A pair of them is often use...
to haul heavy trains on alpine...
routes.

20 8147L

Locomotiva elettrica serie Ae...
delle SBB; livrea verde-grigio...
ghezza fuori respingenti mm 205...
Supertrazione.
Electric locomotive Class Ae 6/6...
SBB in its green-grey livery. Overall...
length mm 205. **Supertraction.**

20 8031L

Elettromotrice serie RBe 4/4" delle...
SBB; livrea verde-grigio. Lunghez...
fuori respingenti mm 260. **Super...**

Locomotiva elettrica serie Re 4/4" delle SBB, livrea verde-grigio. Lunghezza fuori respingenti mm 170. **Trasmissione cardanica singola.**
*Electric locomotive Class Re 4/4" of SBB. Green-grey livery. Overall length mm 170. **Single joint transmission.***

20 8157ACL
 Modello predisposto per funzionamento in corrente alternata. **Trasmissione cardanica singola.**
*Model in AC version. **Single joint transmission.***

20 8156ACL
 Modello predisposto per il funzionamento in corrente alternata, livrea rosso/crema. **Trasmissione cardanica singola.**
*Model in AC version, red-white "Swiss Express" livery. **Single joint transmission.***

20 8117L
 Locomotiva elettrica serie Ae 3/6' delle SBB del lotto 10677-10714; livrea verde-grigio. Lunghezza fuori respingenti mm 165. **Supertrazione.**
*Electric locomotive Class Ae 3/6' of SBB (group 10677-10714). Green-grey livery. Overall length mm 165. **Supertraction.***



20 8157L

20 8157ACL



20 8117L



20 1639L



NEW₈₈

20 8144AC



20 1639L
 Locomotiva Svizzera Diesel
 Am 4/4 delle CFF (ex V200
 DB) per treni da lavoro e
 corso. Scritte esatte non
 C
 nosciute al momento della
 del catalogo.
 Swiss Diesel locomotive
 4/4 of CFF (ex V200 of DB)
 working express trains. Exac
 tions not yet known at the
 catalogue going to press.

Le più diffuse e note
 diesel delle SBB sono quelle
 serie Bm 4/4, costruite dalle
 nel decennio 1960-70. Hanno
 gio Bo-Bo, dispongono di un
 re diesel Sulzer V12 di 1200
 motori elettrici sui quattro
 ghe 12,6 metri, pesano in se
 72 tonnellate e possono svilu
 la velocità massima di 75 km
 sono entrate in servizio 46
 The most popular and number
 diesel locomotives of SBB are
 the Bm 4/4 Class, a Bo-Bo die
 electric locomotive built by Su
 fitted with a 1200 HP Sulzer
 generator and 4 electric mot
 They are 41 feet long, weigh
 tons and can attain a top spee
 47 mph. 46 units are current
 use.

AC **20 8144AC**

WS Locomotiva diesel-elettri
 rie Bm 4/4 delle SBB in
 rossa. Lunghezza fuori respin
 mm 145. **Supertrazione.** Fun
 nante in corrente alternata.
 Diesel electric locomotive Cla
 4/4 of SBB in its red livery. O
 length mm 145. **Supertraction**
 rail AC operating.

20 8144

Locomotiva diesel-elettrica ser
 4/4 delle SBB; livrea marrone
 gio. Lunghezza fuori respin
 145. **Supertrazione.**
 Diesel electric locomotive Cla
 4/4 of SBB in its brown-grey
 Overall length mm 145. **Super
 traction.**

20 8144



30 9159

Carrozza passeggeri di 2° classe delle Ferrovie Federali Svizzere SBB-CFF-FFS - L. 233 mm.
Passenger coach, 2nd class, type B, of the SBB-CFF-FFS - Length 233 mm.



30 9112

Carrozza passeggeri di 1° classe delle Ferrovie Federali Svizzere SBB-CFF-FFS - L. 265 mm.
Passenger coach, 1st class, type A, of the SBB-CFF-FFS - Length 265 mm.



30 9297K

Stesso vagone lunghezza reale con agganciamento corto.
Same coach as above but real scale and short coupling mechanism.



30 9269

Carrozza passeggeri di 2° classe delle Ferrovie Federali Svizzere SBB-CFF-FFS - L. 265 mm.
Passenger coach, 2nd class, type B, of the SBB-CFF-FFS - Length 265 mm.

30 9189

Carrozza passeggeri di 2° classe delle Ferrovie Federali Svizzere SBB-CFF-FFS - L. 265 mm.
Passenger coach, 2nd class, type B, of the SBB-CFF-FFS - Length 265 mm.



30 9272K



30 9272K
Carrozza passeggeri
nuovo «Treno navetta
CFF», colorazione grigio
scuro con porte rosse - L.
Passenger coach "NP2" of
grey/blu livery with red
Length 272 mm.

NEW88

30 9268K



30 9268K
Carrozza passeggeri di 2ª
EW1 delle Ferrovie Federali
- L. 272 mm.
Passenger coach, 2nd class
EW1 of the SBB-CFF-FFS - L.
272 mm.

30 9151L



30 9151L
Carrozza pilota di 2ª classe
minazione frontale, tipo BD1
Ferrovie Federali Svizzere
FFS - L. 292 mm.
Driving coach with front
2nd class, type BD1, of the
FFS - Length 292 mm.

30 9332

Carrozza bagagliaio delle Ferrovie Federali Svizzere SBB-CFF-FFS nella nuova colorazione - L. 211 mm.
Luggage coach of SBB-CFF, type D-ZW II in new two-colored livery - Length 211 mm.



30 9332

30 9175

Carrozza passeggeri «Cafeteria» delle Ferrovie Federali Svizzere SBB-CFF-FFS - L. 268 mm.
Passenger coach "Cafeteria", type SRm, of the SBB-CFF-FFS - Length 268 mm.



30 9175

30 9245

Carrozza «Self-Service», con pantografo, delle Ferrovie Federali Svizzere SBB-CFF-FFS - L. 265 mm.
Self Service coach with pantograph, type WR, of the SBB-CFF-FFS - Length 265 mm.



30 9245

30 9259

Carrozza a cuccette tipo Bcm di 2ª classe della serie «Eurofima» delle Ferrovie Federali Svizzere SBB-CFF-FFS - L. 268 mm.
Sleeping coach "Eurofima"/2nd class, type Bcm, of the SBB-CFF-FFS - Length 268 mm.

30 9259





20 8190L

20 8190ACL

20 8190L

Locomotiva elettrica della serie 1042661 delle Ferrovie Federali Austriache ÖBB, ultima versione in colori arancio sangue/grigio. **Doppia trasmissione cardanica.** Electric locomotive series 1042661 of Austrian Federal Railways ÖBB, last version, blood-orange/grey livery. **Double joint transmission.**

20 8190ACL

Modello predisposto per il funzionamento in corrente AC. **Trasmissione cardanica singola.** Model in AC version. **Single joint transmission.**

20 8191L

Locomotiva elettrica universale serie 104245 delle Ferrovie Federali Austriache ÖBB, 2ª serie di costruzione nella colorazione arancio sangue/grigio. **Doppia trasmissione cardanica.**

Universal electric locomotive series 104245 of Austrian Federal Railways ÖBB, 2nd manufactured series, blood-orange and grey livery. **Double joint transmission.**



20 8191L

20 8192L

Locomotiva elettrica universale serie 104242 delle ÖBB, 2ª serie di costruzione nella colorazione originaria verde. **Doppia trasmissione cardanica.**

Universal electric locomotive series 104242 of Austrian Federal Railways ÖBB, in the original green livery. **Double joint transmission.**



20 8192L

NEW₈₈

Le locomotive diesel della serie 2043, progettate come macchine di linea per il traino di convogli misti, sono state costruite dalla Jenbacher Werke e consegnate a partire dal 1962.

Dotate di un grosso motore diesel V12 di 1500 HP e di trasmissione idraulica sui quattro assi, pesano 67 tonnellate e possono raggiungere la velocità massima di 100 km/h.

The diesel locomotives Class 2043, designed for the haulage of mixed trains, were built by Jenbacher Werke and delivered since 1962. Fitted with a 1500 HP V12 diesel engine and a hydraulic transmission



NEW₈₈

on the four axles, they weigh 67 tons and can reach 62 mph top speed.

20 8131L

Locomotiva diesel-idraulica serie 2043 delle ÖBB; livrea arancio-bianco-nero. Lunghezza fuori respingenti mm 176. **Supertrazione.** Diesel-electric locomotive Class 2043 of ÖBB in its orange-white-black livery. Overall length mm 176. **Supertraction.**

Le Ferrovie Federali Austriache (ÖBB) hanno introdotto nel 1959 la serie 2067 di locomotive diesel da manovra, con rodiggio C a tre assi accoppiati.

The Austrian Federal Railways (ÖBB) introduced a new shunting diesel locomotive Class 2067 in 1959.

20 8141L

Locomotiva diesel da manovra serie 2067 delle ÖBB, rodiggio C. Lunghezza fuori respingenti mm 119.

Supertrazione. Diesel shunting locomotive Class 2067 of ÖBB; C wheel arrangement. Overall length mm 119. **Supertraction.**



30 9140



30 9140

Carrozza passeggeri di 2° classe, tipo Bpo, delle Ferrovie Austriache ÖBB - L. 265 mm.

Passenger coach, 2nd class, type Bpo, of ÖBB - Length 265 mm.

30 9166

Carrozza passeggeri di 2° classe, tipo Bpoz, delle Ferrovie Austriache ÖBB - L. 265 mm.

Passenger coach, 2nd class, type Bpoz of ÖBB - Length 265 mm.



30 9166

I convogli automotori VT 08 delle Ferrovie Federali Germaniche (DB) sono entrati in servizio nel 1952 come treni veloci sulle linee di grande comunicazione fra le principali città tedesche. Di diversa composizione (da 3 a 6 elementi), sono equipaggiati con un motore diesel 12 V di 800-1000 HP di potenza e con trasmissione idraulica. Pesano 120 tonnellate e possono trasportare fino a 138 passeggeri alla velocità di 140 km/h.

The VT08 diesel railcars of German federal Railways (DB) started their service as fast passenger trains in 1952. They may be used in a three or six-unit composition. Powered by a V12 diesel engine with an output of 800-1000 HP and driven by a hydraulic transmission, they can carry 138 passengers at a top speed of 87 mph. The total weight is 120 tons.



20 1041 - Carrozza centrale di 1^a/2^a classe. *First/second class coach.*



Sul finire degli anni '30 la Krupp costruì per conto della Deutsche Reichsbahn (DR) una locomotiva diesel-elettrica espressamente concepita per il traino di cannoni montati su affusto ferroviario. Consisteva di una motrice doppia a 8 assi, della quale entrarono in servizio 12 unità fra il 1939 e il 1941. Tutte operarono sia sul fronte orientale sia in territorio francese. Krupp delivered some diesel-electric locomotives, specially designed to haul heavy railway guns, to Deutsche Reichsbahn (DR) in the late Thirties. They consisted of twin four-driven-axle units, powered by electric motors, fed by a diesel generator. Twelve locomotives of this type were put into service in 1939-41 and they were all used for military purposes, hauling railway guns together with some service coaches and wagons.



30 3500 - Cannone «Leopold» K5 montato su affusto ferroviario a due carrelli di 6 assi ciascuno. Lunghezza 357 mm. Acquistabile separatamente. Gun «Leopold» K5, mounted on a special 12-axle railway bogie. Overall length mm 357. Separately available.





**14 9808
INTERCITY VT 08**

Confezione «Golden Series» contenente un convoglio automotore VT 08 delle DB, nella livrea rosso - grigio - nero; composto di tre elementi: 20 **1040L** - carrozza-pilota di 2° classe. **Alta velocità**

20 **1041** - carrozza centrale di 1°/2° classe

20 **1042L** - carrozza-pilota di 2° classe, senza motore.

Il convoglio può essere integrato da uno o più elementi centrali:

20 **1041**, acquistabili separatamente.

INTERCITY VT08

"Golden Series" set of a diesel rail-car Class VT08 of DB, in its red-grey-black livery. Consisting of three units:

20 **1040L** - second class powered leading coach. **High speed**

20 **1041** - first/second class coach

20 **1042L** - dummy second class rear-end coach, without motor.

The train can be enlarged by one or more additional units 20 **1041**, separately available.

AC WS 14 9808AC

Modello predisposto per il funzionamento in corrente alternata. **Alta velocità.**

Model in AC version. **High speed.**



**14 9704
TRENO MILITARE**

Confezione «Golden Series» contenente un convoglio militare tedesco della seconda guerra mondiale, verniciato nella caratteristica colorazione mimetica, e così composto:

20 **8116L** - locomotiva diesel, in due unità accoppiate. **Supertrazione**

30 **9197** - carrozza passeggeri di servizio a carrelli

30 **3508** - carro chiuso a due assi

30 **3500** - cannone «Leopold» K5 montato su affusto ferroviario a due carrelli di 6 assi ciascuno

30 **3504** - carro a due assi con sponde.

MILITARY TRAIN

"Golden Series" set of a German military train of the Second World War, in its camouflage painting. Consisting of five units:

20 **8116L** - diesel twin-unit locomotive. **Supertraction**

30 **9197** - service passenger bogie coach

30 **3508** - four wheel covered wagon

30 **3500** - gun "Leopold" K5, mounted on a special 12-axle railway bogie

30 **3504** - four wheel open wagon.

Gli elettrotreni a tre elementi ET 30 delle Ferrovie Federali Germaniche (DB) sono stati progettati per assicurare il servizio pendolare fra i grandi centri abitati nella regione della Ruhr. Entrati in servizio nel 1956, si misero in luce per le loro eccezionali doti di accelerazione e frenata. La velocità massima era di 120 km/h.

The multiple-unit electric trains Class ET 30 of the German Federal Railways (DB) have been designed for the suburban rail service in the Ruhr area. They were introduced in 1956 and showed very good acceleration and braking. Top speed is 75 mph.



20 1057 - Carrozza centrale di 1°/2° classe. First/second class coach.

14 9749

LUFTHANSA AIRPORT EXPRESS

Confezione «Golden Series» contenente un elettrotreno serie ET 403 delle DB, nell'originale livrea giallo-bianco; composto di quattro elementi:

20 1066L - carrozza-pilota. **Alta velocità**; 20 1067 - carrozza centrale di 1° classe; 20 1068 - carrozza centrale ristorante; 20 1069L - carrozza-pilota, senza motore con luci di coda.

Il convoglio può essere integrato da altri due elementi centrali: 20 1067 e 20 1068, acquistabili separatamente.

"Golden Series" set of an electric Intercity train Class ET 403 of DB, in the Lufthansa yellow-white livery. Consisting of four units:

20 1066L - powered front-end coach. High speed. 20 1067 - first class coach; 20 1068 - restaurant coach; 20 1069L - dummy first class rear-end coach, with light.

The train can be enlarged by two additional units, separately available: 20 1067 and 20 1068.

AC 14 9749AC

Modello predisposto per il funzionamento in corrente alternata. **Alta velocità.**

Model in AC version. **High speed.**





14 9800

ET 30

Confezione «Golden Series» contenente un elettrotreno ET 30 delle DB nella livrea originaria rosso-grigio; composto di tre elementi:

20 1056L - carrozza-pilota di 2ª classe. **Alta velocità**

20 1057 - carrozza centrale di 1ª/2ª classe

20 1058L - carrozza-pilota di 2ª classe, senza motore, con luci di coda.

Il convoglio può essere integrato da uno o più elementi centrali:

20 1057, acquistabili separatamente.

"Golden Series" set of an electric train Class ET 30 of DB, in its red-grey livery. Consisting of three units:

*20 1056L - second class powered front-end coach. **High speed***

20 1057 first/second class coach

20 1058L - dummy second class rear coach, with rear light.

The train can be enlarged by one or more additional units 20 1057, separately available.

AC 14 9800AC

WS Modello predisposto per il funzionamento in corrente alternata. **Alta velocità.**

*Model in AC version. **High speed.***

Nel processo di razionalizzazione fra il trasporto aereo e quello su rotaia lungo i medi percorsi, la Lufthansa ha inaugurato nel maggio 1982 uno speciale servizio di elettrotreni veloci fra l'aeroporto di Francoforte e le città di Bonn, Colonia e Düsseldorf. In tal modo i passeggeri dei voli internazionali in arrivo a Francoforte possono raggiungere rapidamente, in coincidenza diretta, le altre città o viceversa. I convogli Lufthansa, appartenenti alla serie di elettrotreni 403/404 delle DB, si compongono di quattro elementi, sono lunghi 109 metri e pesano in servizio 236 tonnellate. Raggiungono i 200 km/h.

In the rationalization plan developed by the German Lufthansa airlines for an integrated system of air and railway routes, a special train service was inaugurated between Frankfurt airport and the towns of Bonn, Köln and Düsseldorf in May 1982. Thus passengers arriving at the airport from abroad can reach these towns rapidly and vice versa. The Lufthansa electric trains belong to the Class Et 403 of the German Federal Railways (DB). They have a four-unit arrangement, an overall length of 358 feet and a weight 236 tons. Top speed is 125 mph.

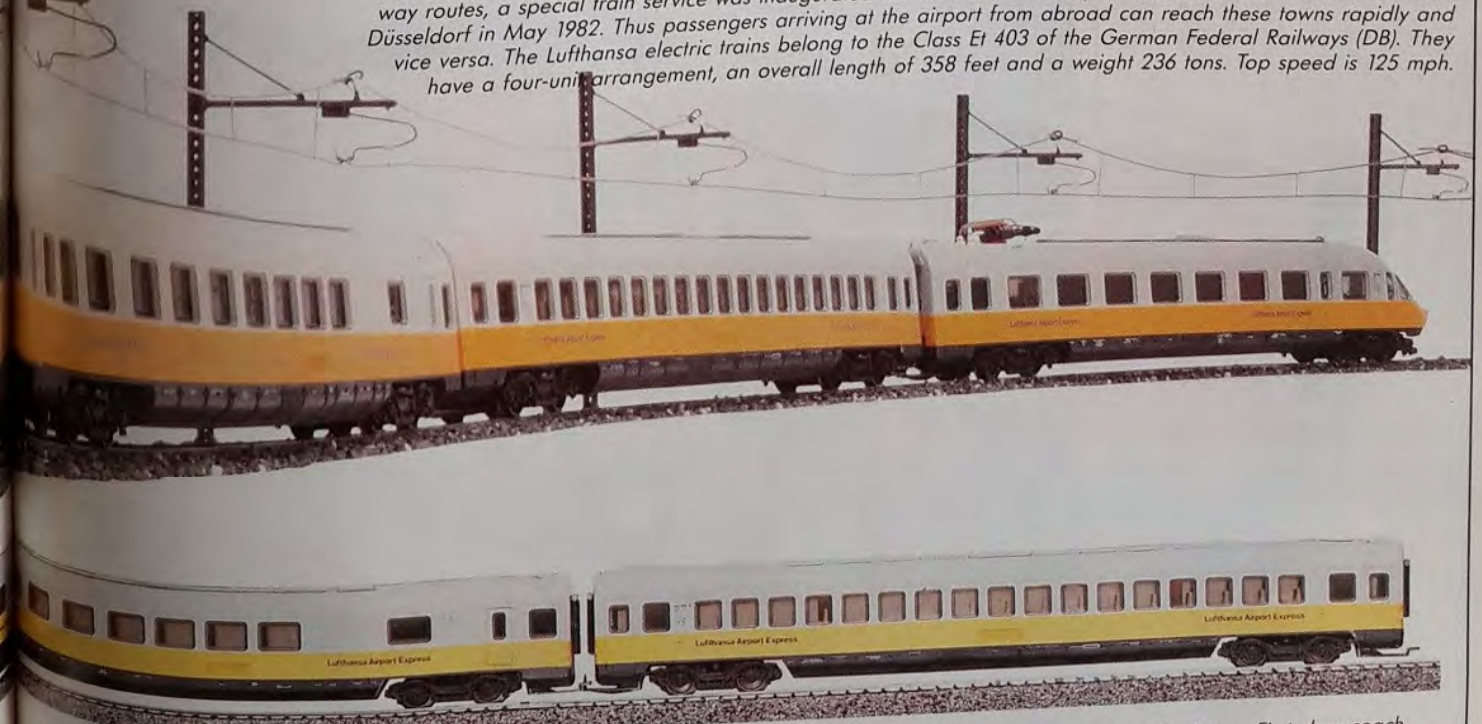

20 1068 - Carrozza centrale ristorante. *Restaurant coach.*

20 1067 - Carrozza centrale di 1ª classe. *First class coach.*



NEW₈₈





Treni pendolari, trainati da locomotive diesel tipo 216, sono ancora in servizio nell'area di Bremen. Questi treni avranno speciali colori, secondo il nuovo sistema di colorazione dei treni delle Ferrovie Tedesche, o saranno rimpiazzati da locomotive diesel.

Commuting trains hauled by diesel locomotives type 216 are still in service in the area of Bremen. In the course of servicing these trains will get special train-colours, according to the new train-colour-system of the German Federal Railways (DB) or they will be replaced by diesel locomotives.

**14 9822K
CITY TRAIN**

Confezione Golden Series che consta di 4 unità di un treno pendolare nella livrea arancio-crema.

20 **1633L** - locomotiva diesel tipo 216. **Trasmissione a doppio cardano**

30 **9248KS** - carrozza di 2° classe

30 **9239KS** - carrozza ristorante

30 **9250KS** - carrozza pilota di coda di 2° classe.

CITY TRAIN

"Golden Series" set consisting of four units commuting train in orange/cream livery.

20 **1633L** - diesel locomotive type 216. **Double joint transmission**

30 **9248KS** - second class coach

30 **9239KS** - restaurant coach

30 **9250KS** - second class rear-end pilot coach.

AC WS 14 9822ACK

Modello predisposto per il funzionamento a corrente alternata. **Trasmissione cardanica singola.**

Model in AC version. **Single joint transmission.**



I treni FD, trainati da locomotive elettriche, si combinano con carrozze TEE degli anni 80. L'attrezzatura delle carrozze è equivalente allo standard dei treni Intercity e delle norme RIC, 180 Km/h. Nella livrea rosso-crema e blu oceano-crema sarà conservata per tutti i treni completi, anche nell'era dei treni Intercity.

The FD trains, hauled by electric locomotives, are combined with TEE coaches of the 1980ies. The equipment of the coaches is equivalent to the standard of the IC trains and RIC norms, 180 Km/h. Red/cream and oceanblue/cream livery.



NEW⁸⁸

In servizio sulle linee Europee ad alta velocità. All'inizio si trattava di treni TEE degli anni 70 e 80 che congiungevano le città Europee su tutto il continente, ora rimpiazzati da treni Intercity più veloci. Treni veloci con attrezzature interne molto confortevoli, aria condizionata, telefono. Una modernissima tecnologia rende possibile viaggiare quasi senza rumore ad una velocità di 200 Km/h.

At first there were TEE-trains of the 1970ies and 80ies connecting European cities all over the continent, now they are replaced by the faster IC-trains. Fast trains with comfortable interior equipment, air-conditioning, phone. A very modern technology makes it possible to travel nearly noiseless with a speed of 200 Kph.



NEW⁸⁸



IC/FD

Confezione «Golden Series» composta da quattro elementi:

20 **8119L** - locomotiva rosso-crema.

Trasmissione a doppio cardano

30 **9220K** - carrozza di 1ª classe

30 **9221K** - carrozza di 2ª classe

30 **9337K** - carrozza bagagliaio.

INTERREGIO-TRAVELTRAINS

«Golden Series» set formed by 4 elements:

20 **8119L** - red-cream locomotive.

Double joint transmission

30 **9220K** - 1st class coach

30 **9221K** - 2nd class coach

30 **9337K** - luggage coach.

AC 14 **9824ACK**

WS Modello predisposto per il funzionamento in corrente alternata. **Trasmissione cardanica singola.**

Model in AC version. **Single joint transmission.**

14 9823K

INTERCITY TEE/IC

Confezione «Golden Series» composta da quattro elementi:

20 **8142L** - locomotiva elettrica 120 rossa. **Trasmissione a doppio cardano**

30 **9167K** - 1ª classe TEE-IC Avms 207, carrelli MD 52

30 **9168K** - 1ª classe TEE-IC Apmz 121, carrelli MD 52

30 **9225K** - TEE-IC carrozza ristorante «Quick-pick», carrelli MD 52.

TEE/IC

«Golden Series» set formed by 4 elements:

20 **8142L** - electric locomotive 120, red. **Double joint transmission**

30 **9167K** - first class TEE-IC Avms 207, bogies MD 52

30 **9168K** - first class TEE-IC Apmz 121, bogies MD 52

30 **9225K** - TEE-IC «Quick-Pick» restaurant, bogies MD 52.

AC 14 **9823ACK**

WS Modello predisposto per funzionamento a corrente alternata. **Trasmissione cardanica singola.**

Model in AC version. **Single joint transmission.**

20 1640L

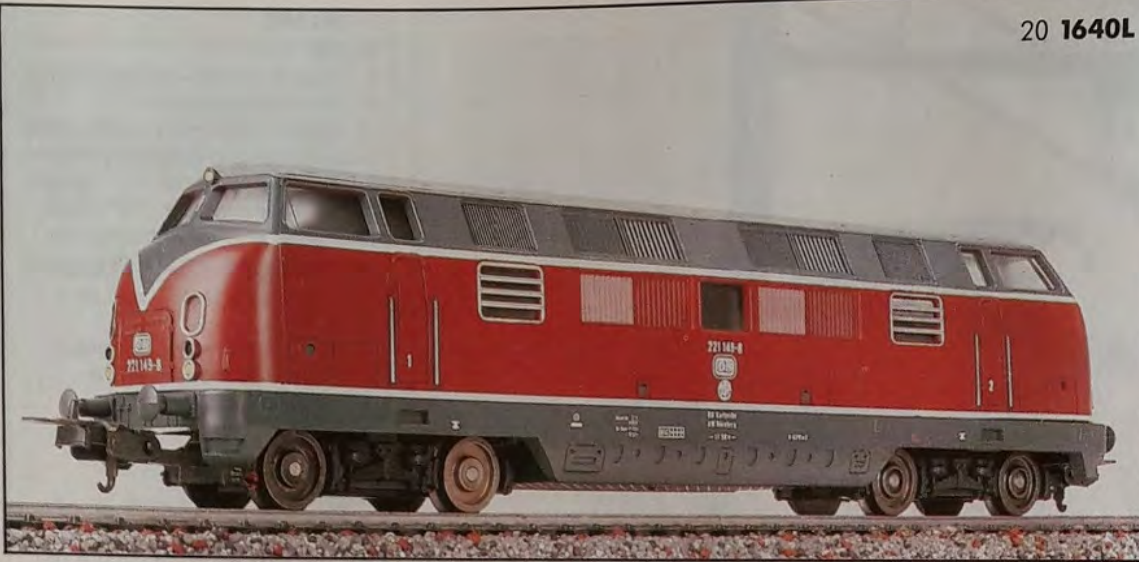

CLASS 221

20 1640L

Locomotiva diesel-idraulica serie 221 delle DB; livrea rosso-grigio-bianco. Lunghezza fuori respingenti mm 210. **Supertrazione.**
*Diesel-hydraulic locomotive Class 221 of DB, in its original red-grey-white livery. Overall length mm 210. **Supertraction.***

20 8114L



CLASS 288

Modificate rispetto alle locomotive diesel-elettriche prodotte nel 1939 dalla Krupp per il traino di cannoni su affusto ferroviario, le motrici a due unità accoppiate di 4 assi ciascuna (rodiggio Do+Do) vennero incorporate nel parco delle Ferrovie Federali Germaniche (DB) nel 1952 sotto la denominazione BR 188. Riclassificate nel 1969 come serie 288 sono state radiate dal servizio nel 1971.

The diesel-electric locomotives, specially developed by Krupp to haul heavy railway guns in 1939-1940, were incorporated into the motive stock of the German Federal Railways (DB) as Class 188 in 1952. They were renumbered as Class 288 in 1969 and withdrawn in 1971.

20 8114L

Locomotiva diesel-elettrica serie 288 delle DB; livrea rosso-grigio. Lunghezza fuori respingenti mm 258.

Supertrazione.

*Diesel-hydraulic locomotive Class 288 of DB in its red-grey livery. Overall length mm 258. **Supertraction.***



CLASS 230

20 1643L
 20 1643ACL
 Locomotiva diesel-idraulica serie 230 delle DB; livrea rosso-grigio. Lunghezza fuori respingenti mm 232. **Doppia trasmissione cardanica.**

Diesel-hydraulic locomotive Class 230 of DB in its original red-grey livery. Overall length mm 232. **Double joint transmission.**

20 1643ACL
 Modello predisposto per il funzionamento a corrente alternata. **Trasmissione cardanica singola.**
 Model in AC version. **Single joint transmission.**

20 1644L
 Locomotiva diesel-idraulica tedesca «Krauss-Maffei», serie 230, nella livrea d'origine rosso-bianco. Lunghezza fuori respingenti mm 232. **Doppia trasmissione cardanica.**
 Diesel-hydraulic locomotive "Krauss-Maffei" Class 230 in its original red-white livery. Overall length mm 232. **Double joint transmission.**

20 1644ACL
 Modello predisposto per il funzionamento a corrente alternata. **Trasmissione cardanica singola.**
 Model in AC version. **Single joint transmission.**

CLASS 628

20 1080L
 Automotrice diesel serie 628 (VT1) delle DB; livrea grigio-bianca e rimorchio-pilota serie 628 (VT2) delle DB, senza motore. Lunghezza fuori respingenti mm 510. **Supertrazione.**

Diesel railcar class 628 (VT1) of DB, in its grey-white livery, and diesel railcar trailer Class 628 (VT2) of DB, without motor. Overall length mm 510. **Supertraction.**



20 1643L
 20 1643ACL



20 1644L
 20 1644ACL

AC
 WS
 20 1080ACL
 Modello predisposto per il funzionamento a corrente alternata. **Supertrazione.**
 Model in AC version. **Supertraction.**

NEW⁸⁸

20 1080L
 20 1080ACL



20 8119L

20 8119ACL



NEW'88

CLASS 103

20 8119L

Locomotiva elettrica Co'-Co' serie E103 delle DB, livrea rosso-crema. Lunghezza fuori respingenti mm 223. **Doppia trasmissione cardanica.**
 Electric Co'-Co' locomotive, Series E103 of DB, red-cream livery. Overall length mm 223. **Double joint transmission.**

AC 20 8119ACL

Modello predisposto per funzionamento a corrente alternata. **Trasmissione cardanica singola.**
 Model in AC version. **Single joint transmission.**

20 8120L

20 8120ACL



NEW'88

AC 20 8120ACL

Modello predisposto per il funzionamento a corrente alternata. **Trasmissione cardanica singola.**

Model in AC version.

20 8120L

Locomotiva elettrica Co'-Co' serie E103 delle DB, livrea rossa. Lunghezza fuori respingenti mm 223. **Doppia trasmissione cardanica.**
 Electric Co'-Co' locomotive, Series E103 of DB, red livery. Overall length mm 223. **Double joint**

CLASS 120

La più recente serie di locomotive elettriche delle Ferrovie Federali Germaniche (DB) è la 120, realizzata per far fronte al servizio veloce per passeggeri o merci alla velocità massima di 160 km/h.

The most modern Class of German Federal Railways (DB) electric locomotives is the 120, designed to cover an extensive part of the German trunk haulage, passenger and freight, at 100 mph.

20 8142L
Locomotiva elettrica, serie 120 delle DB, livrea rossa. **Doppia trasmissione cardanica.**
Electric locomotive series 120 of DB; red livery. **Double joint transmission.**

20 8142ACL
Modello predisposto per il funzionamento a corrente alternata. **Trasmissione cardanica singola.**
Model in AC version. **Single joint transmission.**

20 8035L
Locomotiva elettrica serie 120 delle DB, livrea rosso-crema. **Doppia trasmissione cardanica.**
Electric locomotive series 120 of DB; red-cream livery. **Double joint transmission.**

20 8035ACL
Modello predisposto per il funzionamento a corrente alternata. **Trasmissione cardanica singola.**
Model in AC version. **Single joint transmission.**

20 8142L
20 8142ACL



NEW 88

NEW 88

20 8035L
20 8035ACL



20 1629L

20 1629ACL



CLASS 216

20 1629L

Locomotiva diesel-idraulica serie 216 della DB, con nuova livrea crema-blu. **Doppia trasmissione cardanica.**

*Diesel-hydraulic locomotive, series 216 of DB, new cream-blue livery. **Double joint transmission.***



20 1629ACL

Modello predisposto per il funzionamento a corrente alternata. **Trasmissione cardanica singola.**

*Model in AC version. **Single joint transmission.***

20 1633L

20 1633ACL



NEW₈₈

20 1633L

Locomotiva diesel-idraulica serie 216 della DB, con nuova livrea arancio-crema. **Doppia trasmissione cardanica.**

*Diesel-hydraulic locomotive, series 216 of DB, new orange-cream livery. **Double joint transmission.***



20 1633ACL

Modello predisposto per il funzionamento a corrente alternata. **Trasmissione cardanica singola.**

*Model in AC version. **Single joint transmission.***

20 1625L

20 1625ACL



NEW₈₈

CLASS V80

20 1625L

Locomotiva diesel-idraulica serie V80 della DB; livrea rosso-grigio. Lunghezza fuori respingenti mm 147. **Trasmissione cardanica singola.**

*Diesel-hydraulic locomotive series V80 of DB; red-grey livery. Overall length mm 147. **Single joint transmission.***



20 1625ACL

Modello predisposto per il funzionamento a corrente alternata. **Trasmissione cardanica singola.**

*Model in AC version. **Single joint transmission.***

City-Bahn

NEW₈₈



30 9250K
 Carrozza-pilota mista con bagagliaio tipo BDnrzb delle DB.
 Semi driver mixed coach with luggage type BDnrzb of DB.

NEW₈₈

30 9248K
 Carrozza passeggeri di 2° classe tipo BDnrzb delle DB.
 Passenger 2nd class coach type BDnrzb of DB.



NEW₈₈

30 9239K
 Carrozza passeggeri di 1° e 2° classe con scompartimento bar.
 Passenger 1st and 2nd class coach with bar.



OLD TIME

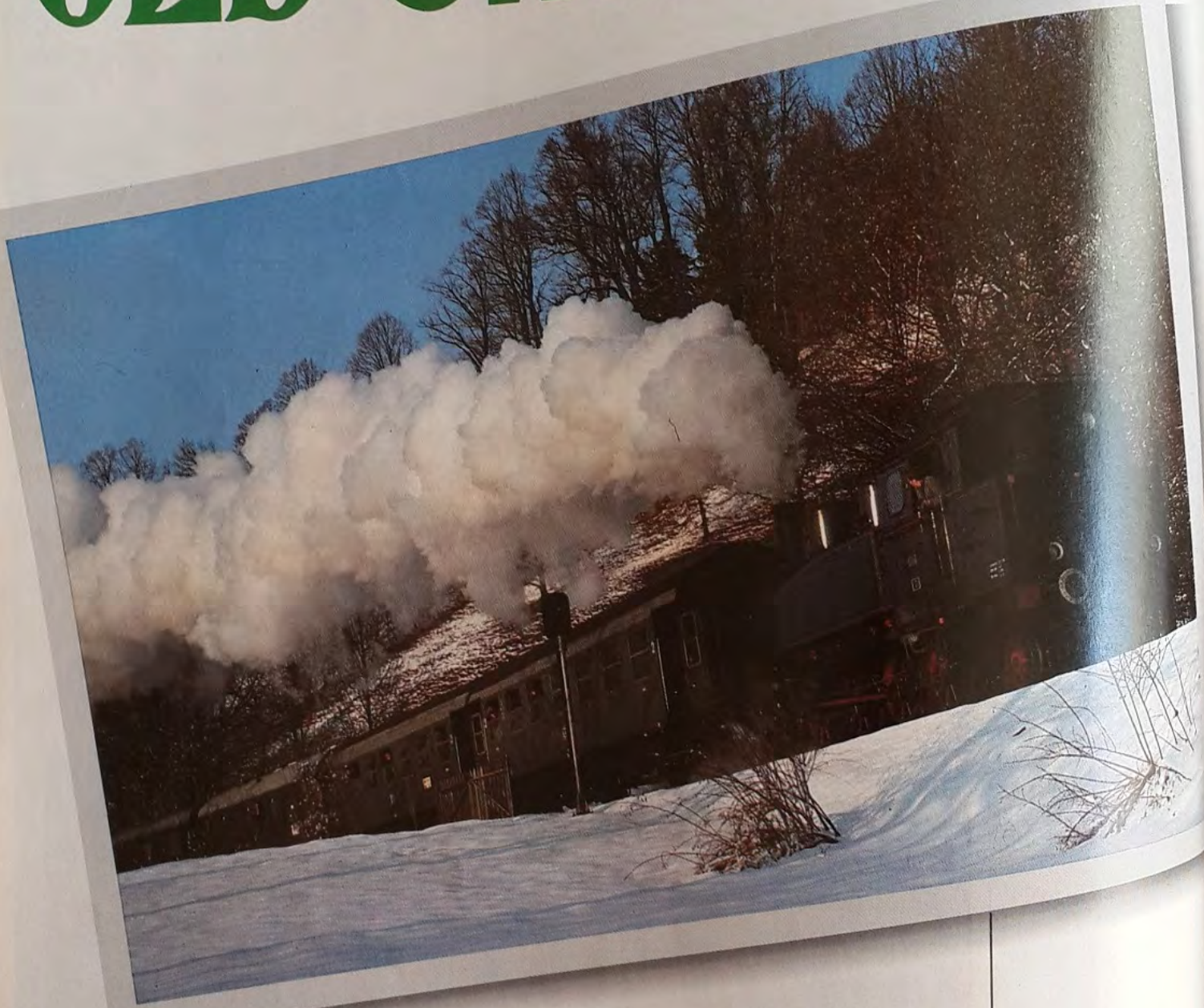

NEW⁸⁸

30 9130K

30 9130K
Carrozza passeggeri di 1^a classe
tipo AB4ü-26, delle Ferrovie Teles
DB - L. 241 mm.
Passenger coach 1st class, type
AB4ü-26, of the DB - Length 241 mm

30 9131K
Carrozza passeggeri di 2° classe, tipo C46-26, delle Ferrovie Tedesche D.B. - L. 241 mm.
Passenger coach, 2nd class, type C46-26, of the DB - Length 241 mm.



30 9349K
Carrozza bagagliaio, tipo Pw4ü delle Ferrovie Tedesche D.B. - L. 217 mm.
Luggage wagon, type Pw4ü of the DB - Length 217 mm.



30 9153
Carrozza passeggeri di 1° classe, tipo Ale-29, delle Ferrovie Tedesche D.B. - L. 149 mm.
Passenger coach, 1st class, type Ale-29, of the DB - Length 149 mm.



30 9154
Carrozza passeggeri di 2° classe, tipo Ble-29, delle Ferrovie Tedesche D.B. - L. 149 mm.
Passenger coach, 2nd class, type Ble-29, of the DB - Length 149 mm.



30 9309
Carrozza bagagliaio, tipo Die-28 delle Ferrovie Tedesche D.B. - L. 149 mm.
Luggage wagon, type Die-28, of the DB - Length 149 mm.



30 9146K



NEW⁸⁸

30 9146K

Carrozza passeggeri mista di 2^a classe e bagagliaio semipilota, tipo BDnz^{F38}, della serie «Silberlinge» delle Ferrovie Tedesche D.B. -

Semidriver passenger coach, 2nd class, type BDnz^{F38}, of the series "Silberlinge" of the DB.

30 9145K



NEW⁸⁸

30 9145K

Carrozza passeggeri mista di componenti di 1^a classe e saloni di 2^a classe, tipo ABnb⁷⁰³, della serie «Silberlinge» delle Ferrovie Tedesche D.B. -

Composite coach 1st class components/2nd class Pullman, type ABnb⁷⁰³, of the series "Silberlinge" of the DB.

30 9144K



NEW⁸⁸

30 9144K

Carrozza passeggeri di 2^a classe, tipo Bnb⁷¹⁹, della serie «Silberlinge» delle Ferrovie Tedesche D.B. -

Passenger coach, 2nd class, type Bnb⁷¹⁹, of the series "Silberlinge" of the DB.

NEW 88

30 9168K
Carrozza passeggeri di 1° classe, tipo Avmz¹²³ delle D.B. - L. 305 mm.
Passenger coach, 1st class, type Avmz¹²³ of the DB - Length 305



30 9168K

NEW 88

30 9225K
Carrozza ristorante Quick-Pick, tipo Wraumz¹³⁹ delle D.B. con pantografo a un braccio - L. 315 mm.
Quick-Pick restaurant coach, type Wraumz¹³⁹ of the DB - Length 315



30 9225K

NEW 88

30 9167K
Carrozza passeggeri di 1° classe tipo Avmz¹¹¹ delle D.B. - L. 305 mm.
Passenger coach, 1st class, type Avmz¹¹¹ of the DB - Length 305 mm.



30 9167K



ICAD
30 9220K
 Carrozza passeggeri di 2ª classe
 Am²⁰³
 2nd class passenger coach Am²⁰³
 DB



30 9221K

NEW '88

30 9221K
 Carrozza passeggeri di 2ª classe
 Bm²³⁵
 2nd class passenger coach Bm²³⁵
 DB



30 9327K

NEW '88

30 9327K
 Carrozza Quick-Pick treno veloce
 WRmh 132
 IC-Fast train Quick-Pick car WRmh
 132 of DB



30 9337K

NEW '88

30 9337K
 Vagone bagagliaio Dms⁹⁰⁵
 Luggage wagon Dms⁹⁰⁵ of DB



NEW 88
RHEINGOLD

30 9165K
 Carrozza passeggeri di 1° classe, tipo WR4üm-62.
 1st class passenger coach, type WR4üm-62.



NEW 88

30 9181K
 Carrozza passeggeri di 1° classe, tipo WR4üm-62.
 1st class passenger coach, type WR4üm-62.



30 9182K
 Carrozza ristorante, tipo WR4üm-62.
 Restaurant-car, type WR4üm-62.

30 9183K
 Carrozza panoramica, tipo AD4üm-62.
 Dome-car, type AD4üm-62.



NEW 88

NEW 88





14 9709

INTERCITY

Confezione «Golden Series» contenente un elettrotreno Intercity serie Eld delle NS, nella nuova livrea giallo-blu; composto di quattro elementi:

- 20 1019L - carrozza-pilota di 1° classe. **Supertrazione**
- 20 1020 - carrozza centrale di 1° classe
- 20 1020 - carrozza centrale di 1° classe
- 20 1021 - carrozza-pilota di 1° classe, senza motore.

INTERCITY

“Golden Series” set of an electric train Class Eld of NS, in its new yellow-blue livery. Consisting of four units:

- 20 1019L - first class powered front-end coach. **Supertraction**
- 20 1020 - first class coach
- 20 1020 - first class coach
- 20 1021 - dummy first class rear-end coach, without motor.



14 9807

INTERCITY

Confezione «Golden Series» contenente un elettrotreno Intercity tipo mBK 381 delle NS, nella livrea giallo-blu-grigio; composto di tre elementi:

- 20 1036L - carrozza-pilota di 2° classe. **Alta velocità**
- 20 1038 - carrozza centrale di 1° classe
- 20 1037 - carrozza-pilota di 2° classe, senza motore.

Il convoglio può essere integrato da uno o più elementi centrali;

- 20 1038, acquistabili separatamente.

INTERCITY

“Golden Series” set of an electric Intercity train Class mBK 381 of NS, in its yellow-blue-grey livery. Formed by three units:

- 20 1036L - second class powered front-end coach. **High speed**
- 20 1038 - first class coach
- 20 1037 - dummy second class rear-end coach, without motor.

The train can be completed by one or more central units 20 1038, separately available.





Le Ferrovie Olandesi (NS) hanno posto in servizio, a partire dal 1956, 47 elettrotreni di quattro elementi ciascuno (serie Eld) per il collegamento rapido fra le principali città. Dispongono di otto carrelli a due assi, quattro dei quali sono azionati da un motore di 270 HP. Convertiti alcuni anni fa per il servizio Intercity come convogli veloci di 1° classe, possono trasportare circa 200 persone alla velocità massima di 140 km/h. Sono lunghi complessivamente 98,5 metri e il loro peso è prossimo alle 200 tonnellate.

Starting in 1956 the Dutch Railways introduced forty-seven four-unit electric trains Class Eld for fast suburban service on main routes. They featured eight twin-axle bogies, four of them being driven by a 270 HP engine. Converted into first class Intercity trains a few years ago, they can carry about 200 passengers at 87 mph. They are 321 feet long and weigh about 200 tons.

L'elettrotreno tipo mBK 381 delle Ferrovie Olandesi (NS) viene adibito per il servizio Intercity sulle linee a grande traffico che collegano le città più importanti dei Paesi Bassi. La composizione base consiste di tre elementi, dei quali due, in testa e in coda, sono caratterizzati dalla cabina di guida sopraelevata posta all'estremità anteriore.

The multiple-unit electric trains Class mBK of the Dutch Railways (NS) are used for the Intercity passenger service on the main routes of the Low Countries. The basic formation consists of three units the two end units featuring a raised, streamlined driving cab.



14 9721

TRENO INTERCITY

Questa confezione Golden Series contiene una locomotiva elettrica Olandese di tipo «Americano» della serie 1200, con 3 carrozze per il traffico Intercity del periodo 1952-1970. Locomotiva senza marchio NS, carrozze in colorazione e numeri originali. La confezione comprende:

- 20 **8188L** - locomotiva elettrica 1220 in blu berlin. **Supertrazione**
- 30 **9109S** - carrozza di 1° classe serie A6500
- 30 **9110S** - carrozza di 2° classe serie B6600
- 30 **9305S** - carrozza mista ristorante/bagagliaio serie RD 6950.

INTERCITY TRAIN

This Golden Series box contains a Dutch "American"-type electric loco series 1200, with three coaches for Intercity-traffic of the period 1952-1970. Loco without the NS mark, coaches in original condition with original numbers. Golden Series set includes:

- 20 **8188L** - electric loco 1220 in Berlin Blue. **Supertraction**
- 30 **9109S** - 1st class coach series A6500
- 30 **9110S** - 2nd class coach series B6600
- 30 **9305S** - composite restaurant-luggage coach series RD 6950.



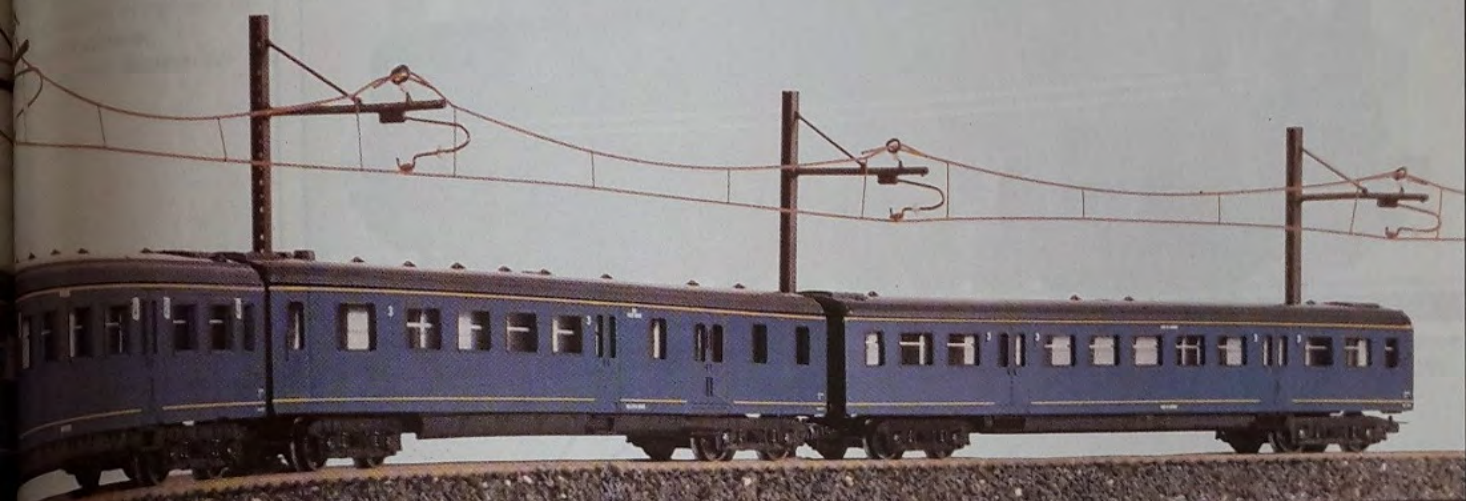

20 8188L

Locomotiva elettrica olandese serie 1220 nel colore Blu Berlino, periodo 1955-1970. **Supertrazione.**

*Dutch electric locomotive series 1220 in Berlin - blue outfit, period 1955-1970. **Supertraction.***

20 8024L

Locomotiva elettrica serie 1200 delle NS; livrea grigio-giallo. Lunghezza fuori respingenti mm 204. **Supertrazione.**

*Electric locomotive Class 1200 of NS in its original grey-yellow livery. Overall length mm 204. **Supertraction.***

20 8186L



20 8021L



30 9279



30 9280



20 8186L
Locomotiva elettrica Olandese di tipo «Francese» della serie 1300 nella livrea Blu Berlin. Periodo 1955-1970.

Supertrazione.

Dutch "French"-type electric locomotive series 1300, in Berlin Blue livery, period 1955-1970. Supertraction.

Le locomotive elettriche tipo 11 sono destinate al traino di nuove composizioni chiamate «Benelux-Trains», in servizio regolare (ogni ora) tra Amsterdam e Bruxelles, dal settembre 1986. La locomotiva è a doppio voltaggio: 1500 DC e 3000 DC.

The electric locomotive type 11 will haul the new sets of so-called "Benelux"-trains, which came into regular service (every hour) between Amsterdam and Brussels from September 1986 on.

20 8021L

Locomotiva elettrica serie 11 delle Ferrovie di Stato Olandese (N.S.) - L. 210 mm. **Supertrazione.**
Dutch Electric locomotive class 11 - Length mm 210. Supertraction.

30 9279

Carrozza passeggeri di 1° classe delle Ferrovie Olandesi per il nuovo treno «Benelux» Amsterdam-Bruxelles, nei colori misti Belgi-Olandesi, con i nuovi carrelli del tipo Y 32 - L. 264 mm.

First class coach of Dutch Railways for new Benelux-trains Amsterdam-Brussels, in mixed Belgian/Dutch colours, with new bogies type Y32; 10 coaches built; length 264 mm.

30 9280

Carrozza passeggeri di 2° classe delle ferrovie Olandesi per il nuovo treno «Benelux» Amsterdam-Bruxelles, nei colori misti Belgi-Olandesi, con i nuovi carrelli del tipo Y 32 - L. 264 mm.

Second class coach of Dutch Railways for new Benelux-trains Amsterdam-Brussels, in mixed Belgian/Dutch colours, with new bogies type Y32; 18 coaches built; length 264 mm.

... nuova livrea giallo grigio
... l'omologazione.
... locomotive series 1314
... yellow-grey version. **Su-**
...
20 8187ACL
... predisposto per il
... in corrente al-
Supertrazione.
... AC version. **Supertrac-**



EW 88
...
... elettrica Olandese tipo
... della serie 1300, N.
... colori più recenti con pan-
... a braccio singolo. **Super-**
...
... French"-type electric loco
... number 1307, in latest
... with SINGLE ARM
... **Supertraction.**



281
... mista 2° classe e bagagliaio
... per il nuovo treno «Bene-
... Amsterdam-Bruxelles, nei colori
... Belgi-Olandesi, con i nuovi
... del tipo Y 32 - L. 264 mm.
... class coach with luggage -
... compartment for new
... trains Amsterdam-Brussels;
... Belgian/Dutch colours; with
... type Y32; 10 coaches
... length 264 mm.



282L
... zia-pilota con cabina di gui-
... 44 posti di 2° classe. Costruita
... per il nuovo treno «Bene-
... Amsterdam-Bruxelles, nei colori
... Belgi-Olandesi, con i nuovi
... del tipo Y 32 senza motore
... illuminazione frontale - L. 264



... coach with driver's compart-
... and 64 seats of second class
... new push-pull trains Amsterdam-
... in mixed Belgian/Dutch co-
... with boogie



30 9107



30 9310



Intercity di 1^a classe, nella colorazione giallo-blu, delle Ferrovie Olandesi N.S. - L. 264 mm.
First class Intercity passenger coach; yellow-blue livery, of Dutch Railways (N.S.).

30 9107

Carrozza passeggeri per convogli Intercity di 2^a classe, nella colorazione giallo-blu, delle Ferrovie Olandesi N.S. - L. 264 mm.
Second class Intercity passenger coach; yellow-blue livery, of Dutch Railways (N.S.).

30 9310

Carrozza mista per convogli Intercity di 2^a classe e bagagliaio, nella colorazione giallo-blu, delle Ferrovie Olandesi N.S. - L. 264 mm.
Composite luggage/second class Intercity coach; yellow-blue livery, of Dutch Railways (N.S.).

30 9188KL

Carrozza pilota Olandese di 2^a classe del tipo a 2 piani. Composizione minima con una carrozza pilota e 3 miste, trazione a mezza locomotiva elettrica.
Dutch second class, pilot coach doubledecker-type. Minimum composition of one pilot coach and three composite, traction by electric loco.

30 9188KL



NEW 88

Carrozza passeggeri di 1° classe
serie A6500, delle Ferrovie Olandesi
N.S. - L. 253 mm.
Passenger coach, 1st class, series
A6500, of the N.S. - Length 253



30 9110

Carrozza passeggeri di 2 classe, se-
rie B6601 delle Ferrovie Olandesi
N.S. - L. 253 mm.
Passenger coach, 2nd class, series
B6601, of the N.S. - Length 253 mm.



30 9305

Carrozza mista di ristorante e ba-
gagliaio, serie RD6951, delle Ferro-
vie Olandesi N.S. - L. 253 mm.
Composite restaurant/luggage
coach, series RD6951, of the N.S. -
Length 253 mm.



Carrozza a 2 piani mista Olandese
di 1°/2° classe. I treni in servizio an-
dano-ritorno viaggiano con carrozza
LIMA 30 9188K. Convoglio
minimo formato da 3 carrozze.
Each composite doubledecker
coach first and second class. It
runs push-pull-trainsets with LIMA
coach 30 9188K. A minimum
of three composite coaches per set
is needed.

30 9187K



NEW88

20 8065L



20 8065L

Locomotiva elettrica tipo EL 13 delle NSB, livrea marrone-giallo. Lunghezza fuori respingenti mm 167. **Supertrazione.**
Electric locomotive Class EL 13 of NSB. Brown-yellow livery. Overall length mm 167. Supertraction.

20 8130L



20 8130L

Locomotiva elettrica tipo EL 14 delle NSB. Livrea marrone-giallo. Lunghezza fuori respingenti mm 200. **Supertrazione.**
Electric locomotive Class EL 14 of NSB. Brown-yellow livery. Overall length mm 200. Supertraction.

20 8109L



20 8109L

Locomotiva diesel-elettrica serie MZ delle DSB; livrea rosso-nero-bianco. Lunghezza fuori respingenti mm 227. **Supertrazione.**
Diesel-electric locomotive Class MZ of DSB in its original red-black-white livery. Overall length mm 227. Supertraction.

20 1092L

Automotrice diesel serie MR (DMU) delle DSB; colore rosso. Lunghezza fuori respingenti mm 255. **Supertrazione.**

Diesel railcar Class MR (DMU) of DSB, in its original red livery. Overall length mm 255. Supertraction.

20 1093

Automotrice diesel serie MR (DMU) delle DSB; colore rosso, senza motore. Lunghezza fuori respingenti mm 255.

Diesel railcar Class MR (DMU) of DSB, without motor, overall length mm 255.

20 1628L

Locomotiva diesel-elettrica Tipo T43 delle SJ; livrea arancio-blu. Lunghezza fuori respingenti mm 162. **Supertrazione.**

Diesel-electric locomotive Class T43 of SJ in its original orange-blue livery. Overall length mm 162. Supertraction.

AG WS 20 1628ACL

Modello predisposto per il funzionamento in corrente alternata. **Supertrazione.**
Model in AC version. Supertraction.



20 1092L

20 1093

2052L
 motiva elettrica serie Rc2 delle
 inghezza fuori respingenti mm
Supertrazione.
 locomotive Class Rc2 of the
 overall length mm 176. **Super-**

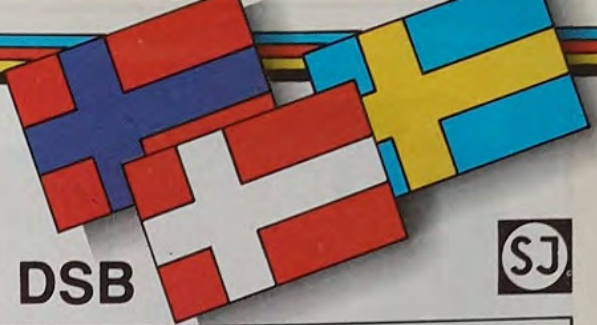
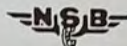

DSB



LOCOMOTIVA ELETTRICA

20 4.
 motiva elettrica tipo Ra delle
 Svedesi. Modello di loco-
 molto conosciuta delle ferro-
 Svedesi. **Supertrazione.**
 «Rapid» fu introdotta nel
 costruita da ASEA.
 usata per treni passeg-
 veloci. **Supertrazione.**

ELETTRIC LOCOMOTIVE

20 4
 of a very famous and popu-
 locomotive. **Supertraction.**
 «Rapid», it was intro-
 in 1955, and manufactured
 ASEA. Mainly used for fast pas-
 senger trains. **Supertraction.**

20 8053ACL
 Modello predisposto per il
 funzionamento in corrente al-
 ternata. **Supertrazione.**
 in AC version. **Supertrac-**

LOCOMOTIVA ELETTRICA

20 8
 motiva alla 20 8053L ma loco-
 motiva 8.
ELETTRIC LOCOMOTIVE
 20 8.
 motiva alla 20 8053L but locomotive
 version 8.

20 8061ACL
 Modello predisposto per il
 funzionamento in corrente al-
 ternata. **Supertrazione.**
 in AC version. **Supertrac-**



20 1628L

20 1628ACL



20 8052L

NEW₈₈

NEW₈₈



20 8053L

20 8053ACL

30 9104



Carrozza passeggeri a comparti di 2° classe delle Ferrovie Danesi D.S.B. - L. 268 mm.

Passenger coach with 2nd class compartments, type B, of the DSB - Length 268 mm.

30 9339



30 9339

Carrozza mista di comparti di 2° classe e bagagliaio, delle Ferrovie Danesi D.S.B. - L. 268 mm.

Composite passenger/luggage coach with 2nd class compartments, of the DSB - Length 268 mm.

30 9150



30 9150

Carrozza passeggeri di 2° classe, tipo B3, delle Ferrovie Norvegesi N.S.B. - L. 265 mm.

Passenger coach, 2nd class, type B3, of the NSB - Length 265 mm.

30 9222



30 9222

Carrozza passeggeri di 1° classe, tipo A2, delle Ferrovie Norvegesi N.S.B. - L. 265 mm.

Passenger coach, 1st class, type A2, of the NSB - Length 265 mm.

30 9308



30 9308

Carrozza mista di comparti passeggeri e bagagliaio, tipo BF12, delle Ferrovie Norvegesi N.S.B. - L. 265 mm.

Composite coach passenger/luggage, type BF12, of the NSB - Length 265 mm.

...passenger coach, type A2, delle Ferrovie Svedesi S.J. - Length 265 mm.



...posseggeri di 2ª classe, tipo delle Ferrovie Svedesi S.J. - Length 265 mm.

30 9158



...con cuccette, tipo delle Ferrovie Svedesi S.J. - Length 265 mm.

30 9270



...ristorante, tipo R3, delle Ferrovie Svedesi S.J. - L. 265 mm.

30 9257



...bragagliaio, tipo F5, delle Ferrovie Svedesi S.J. - L. 265 mm.

30 9335

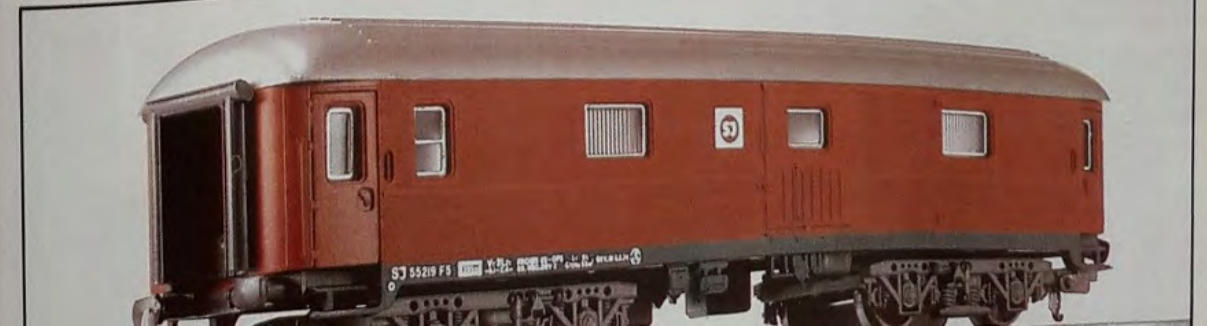



30 9201



**COMPAGNIA INTERNAZIONALE VAGONI LETTO
INTERNATIONAL COMPANY
OF WAGONS-LITS AND
TOURISME**

30 9201

Carrozza passeggeri, tipo Pullman, usata dalla «Compagnie Internationale des Wagons-Lits et du tourisme "CIWLT"» specialmente nella composizione del treno «Orient-Express» - L. 220 mm.

Passenger coach, type pullman, of the C.I.W.L.T. (International Company of Wagons-Lits and Tourisme), utilized also for the Orient Express Train - Length 220 mm.

30 9202



30 9202

Carrozza ristorante della «Compagnie Internationale des Wagons-Lits et du tourisme "CIWLT"» usata nella composizione del treno «Orient-Express» - L. 220 mm.

Restaurant coach C.I.W.L.T. (International Company of Wagons-Lits and Tourisme) utilized also for Orient Express Train - Length 268 mm.

30 9301



30 9301

Carrozza bagagliaio della «Compagnie Internationale des Wagons-Lits et du tourisme "CIWLT"» - L. 220 mm.

Luggage wagon of the C.I.W.L.T. (International Company of Wagons-Lits and Tourisme) - Length 220 mm.

consorzio TEN costituito
 fra le amministrazioni
 di 9 Paesi per la gestio-
 delle carrozze-letto. Le carrozze
 nelle varie lingue significa
 Nuit, Trans Euro nacht,
 (Notte, ecc.) sono di tipo
 con i compartimenti cioè
 convertibili in servizio di
 seconda oppure di classe

International european rail-
 is present the TEN, con-
 established by nine Euro-
 way Administrations to run
 cars business on a
 basis with the old Com-
 internationale des Wagons
 TEN coaches (whose logo
 understandable in the var-
 pages as Trans Euro
 Trans Euro Nuit, Trans Euro
 have a special modular
 easily convertible into
 second class or tourist

coach, tipo M, della «Com-
 internationale des Wagons-
 tourisme "CIWLT"» - L. 268

coach, type M, of the
 International Company of
 and Tourisme) - Length

coach, tipo WLABm, del
 TEN, appartenente alle
 Ferrovie F.S. - L. 268 mm.
 coach "T.E.N.", type
 of the F.S. - Length 268

coach, tipo WLAsm, del
 TEN, appartenente alle
 Ferrovie tedesche D.B. - L. 268 mm.
 coach "T.E.N.", type
 of the D.B. - Length 268



30 9233



30 9238



CARRI MERCI FREIGHT WAGONS

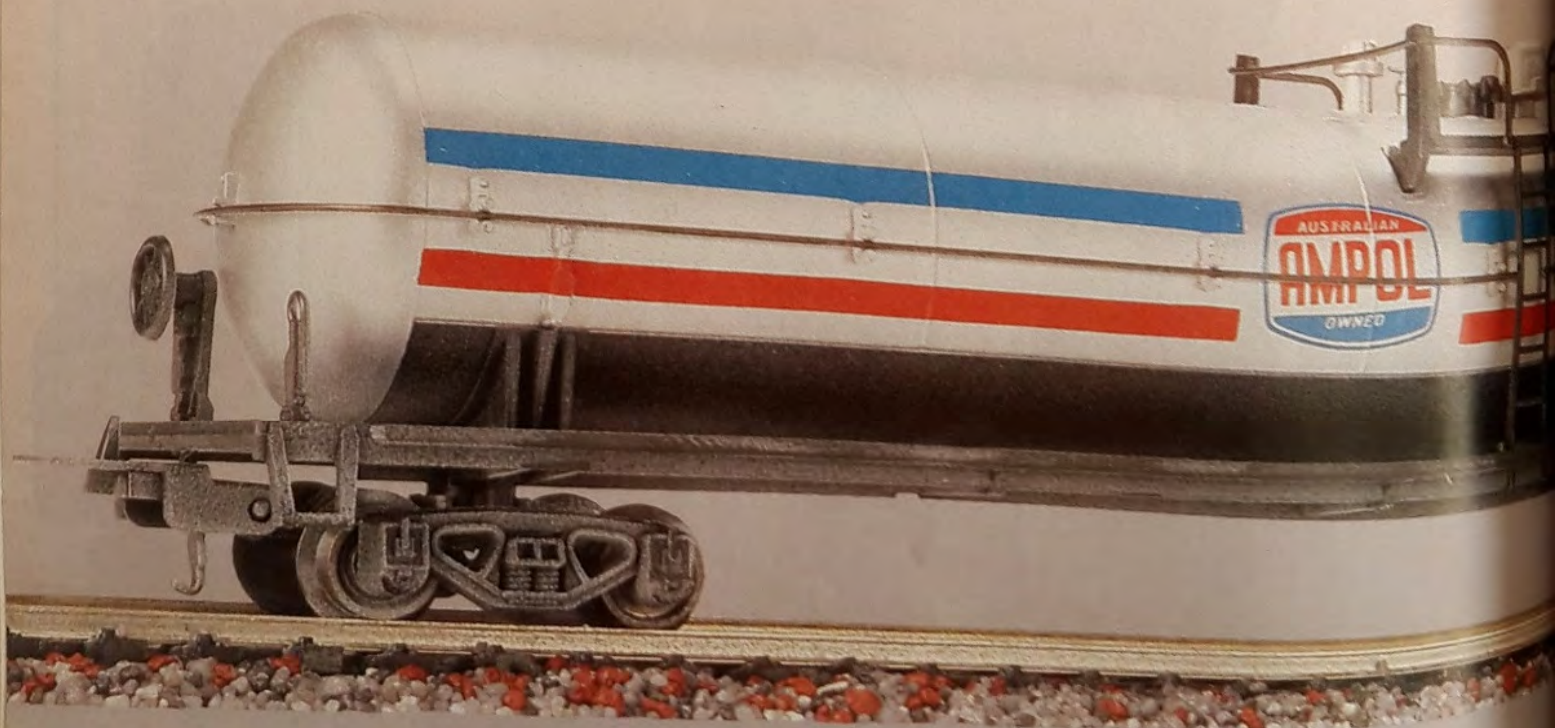
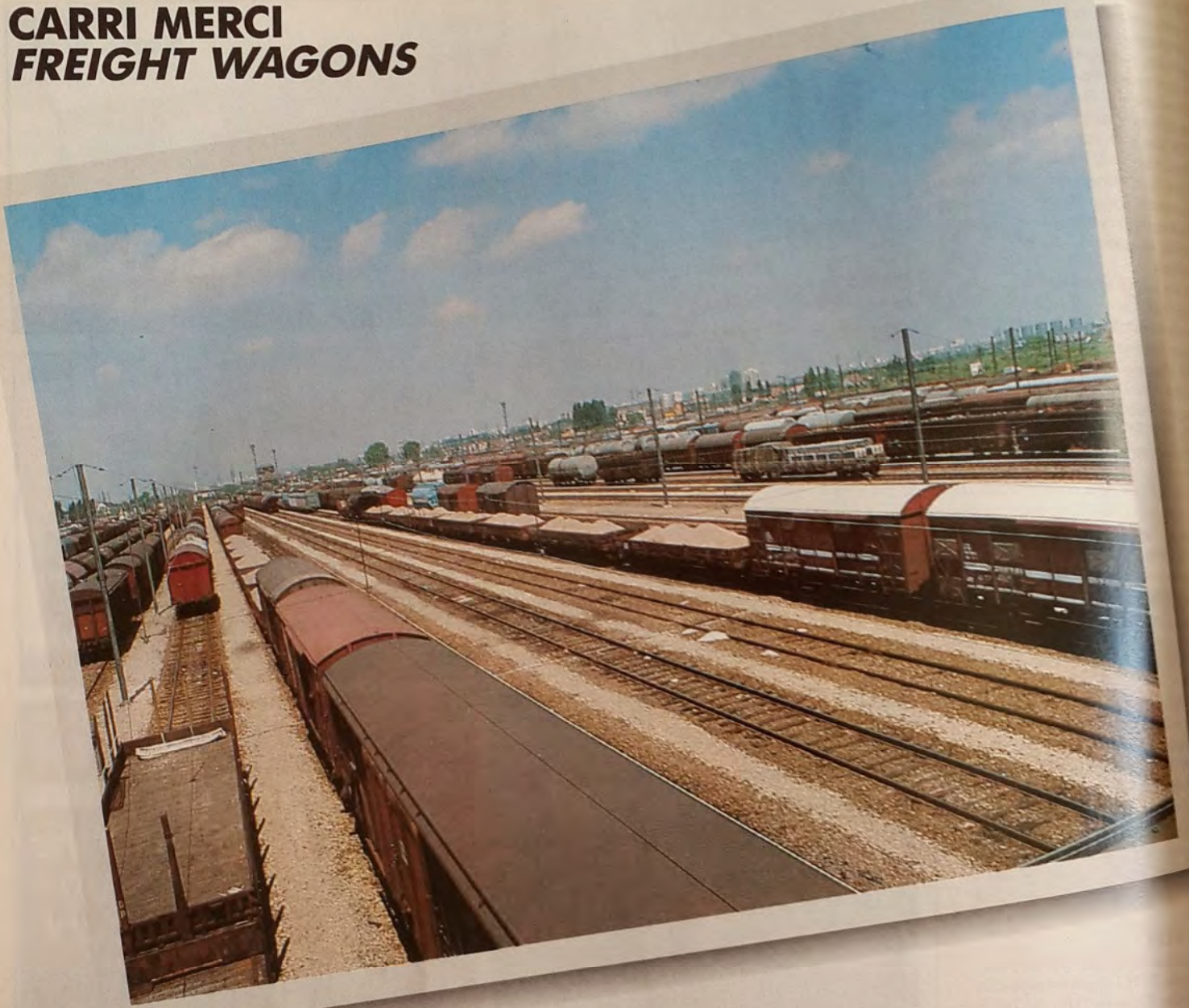

WAGONS
 ...spettacolari in un
 ...sono i carri cisterna,
 ...non solo per il trasporto
 ...petroliferi, ma anche di
 ...di gas compressi o
 ...e infine di liquidi alimenta-
 ...dei ben noti carri a due
 ...entrati in servizio negli ul-
 ...anche i vagoni a carrelli di
 ...cassacchia, che possono an-
 ...lunghe convogli, gra-
 ...maggiore potenza sviluppa-
 ...moderne locomotive.
 ...probably the most impres-
 ...s in a freight train. They
 ...to ensure the trans-
 ...of oil products, chemicals,
 ...or liquified gases as
 ...mentary liquids. In addi-
 ...conventional four-wheel
 ...new big-capacity bogie
 ...were recently introduced
 ...can be used to compose
 ...freight train, thanks also to
 ...improved horsepower of
 ...locomotives.

116 mm.
 Tank wagon "Esso", type Uh -
 Length 116 mm.



30 2711

30 2713
 Carro serbatoio, tipo Uh, «Shell» -
 L. 116 mm.
 Tank wagon "Shell", type Uh -
 Length 116 mm.



30 2713

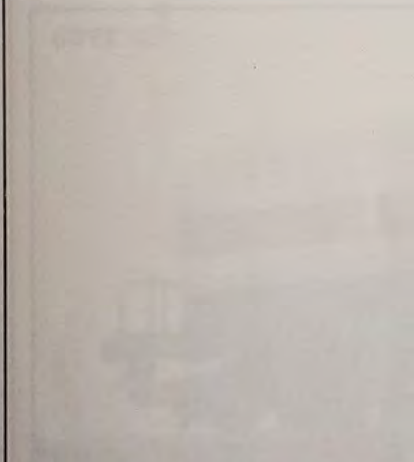

30 3626
 Carro serbatoio da 40' della com-
 pagnia «B.P.» - L. 148 mm.
 40' tank wagon of the "BP" com-
 pany - Length 148 mm.



30 3239
 Carro serbatoio da 62' della com-
 pagnia «Ampol» - L. 220 mm.
 62' tank wagon of the "Ampol"
 company - Length 220 mm.

30 3239

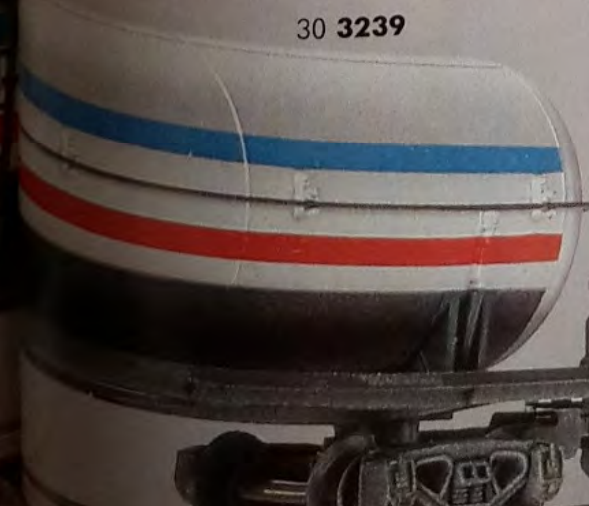

30 3626





30 2903



30 2904



30 2916



Carro serbatoio, tipo Uah, della compagnia «Mobiloil» - L. 190 mm.
Tank wagon, type Uah, of the company "Mobiloil" - Length 190 mm.
30 2904
 Carro serbatoio, tipo Uah, della compagnia «Shellgas» - L. 190 mm.
Tank wagon, type Uah, of the company "Shellgas" - Length 190 mm.
30 2916
 Carro serbatoio, tipo Uah, della compagnia «Agip» - L. 190 mm.
Tank wagon, type Uah, of the company "Agip" - Length 190 mm.

CARRI SILOS ORE WAGONS

Sono impiegati per il trasporto di materiali sfusi (granaglie, farina, cemento, etc.). Sono costituiti da un pianale sul quale sono montati due o più serbatoi verticali intercomunicanti, a riempimento dall'alto. *They are normally used for transportation of miscellaneous materials such as corn, cereals, flour, cement. They consist of a flat wagon, upon which two or more vertical bins are mounted.*

30 2808

Carro a scarico automatico delle S.N.C.F. - L. 105 mm.
Wagon with automatic unloading, of the S.N.C.F. - Length 105 mm.

30 2809

Carro a scarico automatico della compagnia «EVS» - L. 105 mm.
Wagon with automatic unloading, of the company "EVS" - L. 105 mm.

CARRI SCOPERTI A SPONDE FLAT WAGONS

Sono del tipo a due assi oppure a carrelli di tipo unificato europeo. Quelli a due assi sono lunghi 13,9 metri, quelli a carrelli 14 metri; entrambi dotati di sponde ribaltabili alte 45 cm oppure di 12 stanti ribaltabili.

They are the standard Continental type, either four wheel wagons (45 feet long) or bogie wagon (46 feet long). They both can be fitted with low sides or with 12 stanchions.

30 2810

Carro a bascula per trasporto minerali delle D.B. - L. 92 mm.
Bascula wagon for the transport of minerals, of the DB - Length 92 mm.

30 2825

Carro scoperto con garitta per frenatore, con botti «Beaujolais Village» delle F.S. - L. 116 mm.
Open wagon with brake cabin, with casks of wine "Beaujolais Village" - Length 116 mm.

30 2811

Carro scoperto con garitta per frenatore, con trasporto tubi Dalmine delle F.S. - L. 116 mm.
Open wagon with brake cabin, for the transport of pipes "Dalmine" of the F.S. - Length 116 mm.



30 2809



30 2825



30 2811



30 2849



CARRI PIANALI PORTA-CONTAINER

CONTAINER WAGONS

Sono carri pianali a due assi serie R di tipo corrente, lunghi 14,2 metri e con un piano di carico lungo 13 metri; pesano 10,5 tonnellate e sono idonei a viaggiare a 100 km/h. They are basically flat four wheel wagons Class R, with an overall length of 47 feet and a 43 feet long loading platform. They weigh 105 tons and are suitable to run at 60 mph.

30 2849

Carro pianale, tipo Lgjs, con container da 40' «Chiquita» delle S.J. - L. 168 mm.

Flat wagon, type Lgjs, with 40' container "Chiquita", of the S.J. - Length 168 mm.

30 2856



30 2856

Carro pianale, tipo LSS, con container da 20' «Sea Land» e «Danzas» delle D.B. - L. 168 mm.

Flat wagon, type LSS, with 20' containers «Sea Land - Danzas», of the DB - Length 168 mm.



30 2853

Carro pianale con 5 containers «Linjegods» delle N.S.B. - L. 168 mm. Flat wagon with 5 containers "Linjegods", of the NSB - Length 168 mm.

30 2853



... L. 168 mm.
... with 4 spherical contain-
... the DB - Length 168 mm.

SCOPERTI A SPONDE

WAGONS

... carri della serie E a due assi
... a carrelli, provvisti di porte
... con capacità variabile fra i
... (carro E) e i 72 m³ (carro
... lunghezza compresa fra i
... metri, pesano a vuoto fra le
... 20,4 tonnellate.

... standard E Class wagons,
... four wheel or in two bogie
... fitted with side doors and
... overall capacity between 37
... (wagon) and 72³ (Eaos wagon).
... are 30 to 46 feet long and
... 17.7 to 20.4 tons.

30 9042
... coperto con stanti, tipo
... delle D.B. - L. 206 mm.
... wagon with stakes; type SSos,
... DB - Length 206 mm.

30 9043
... coperto a sponde alte, tipo
... delle D.B. - L. 206 mm.
... wagon with side boards, type
... of the DB - Length 206 mm.

30 9064
... coperto a sponde alte, tipo
... delle D.B. - L. 160 mm.
... wagon with side boards, type
... of the DB - Length 160 mm.



30 9042

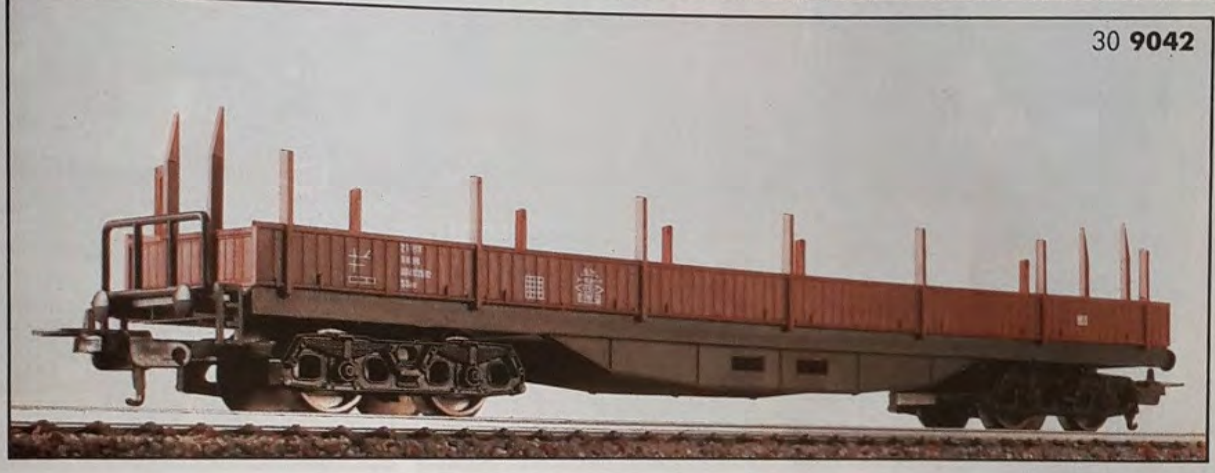

30 9043



30 9064





30 9065

30 9065

Carro scoperto a sponde alte tipo Eaos E81 trasporto sabbia - L. 160 mm.

Open wagon with side boards, type Eaos E81 - Length 160 mm.



30 9045

30 9045

Carro scoperto a sponde alte, tipo Eaos, delle SBB-CFF-FFS - L. 160 mm.

Open wagon with side boards, type Eaos, of the SBB-CFF-FFS - Length 160 mm.



30 3575

30 3575

Carro scoperto, tipo Klm 505, delle D.B. - L. 120 mm.

Open wagon, type Klm 505, of the DB - Length 120 mm.

30 3547

Carro scoperto a stanti e sponde ribaltabili, tipo Litt O, delle S.J. - L. 140 mm.

Open wagon with stakes and overturning side boards, type Litt O, of the SJ - Length 140 mm.

30 3171

Carro scoperto a sponde alte, tipo St, delle F.S. - L. 121 mm.

Open wagon with side boards, type St, of the F.S. - Length 121 mm.

30 3172

Carro scoperto a sponde alte, tipo St, delle S.N.C.F. - L. 121 mm.

Open wagon with side boards, type St, of the S.N.C.F. - Length 121 mm.

30 3174

Carro scoperto a sponde alte e con carico di carbone, tipo St, delle F.S. - L. 121 mm.

Open wagon with side boards and with coal, type St, of the F.S. -

30 3171



30 3172



30 3174



30 3101



**CHIUSI
COAL WAGONS**

Modello con parte apribile, tipo
della N.S.B. - L. 121 mm.
Model with sliding doors, ty-
pe of the NSB - Length 121



30 3102



30 3106



30 3154



30 3161



30 3164



30 3166



30 3554





...so posiz...
...FFS - L 121 mm.
...sional wagon, type Z², of the
...FFS - Length 121 mm.
...so, tipo St, della compa-
...ama - L 121 mm.
...wagon, type St, of the com-
...man, - Length 121 mm.
...so a due assi della com-
...Omalline» - L 121 mm.
...sioned wagon of the compa-
...alline, - Length 121 mm.

30 3105L



...so, tipo St, delle F.S.
...wagon, type St, of the F.S.
...so, tipo Gmhs 50, «ASG»
... - L 121 mm.
...wagon "ASG", type Gmhs
...DB - Length 121 mm.
...so, tipo GS, delle SBB-
... - L 121 mm.
...wagon, type GS, of the SBB-
... - Length 121 mm.
...so, tipo Gbs, delle S.J. - L.
...wagon, type Gbs, of the S.J.
... 158 mm.

30 3546



...so con garitta per frena-
...zionanti a parte apribi-
... delle S.N.C.F.
...wagon with brake cabin,
...ight and sliding doors, type
... S.N.C.F. - Length 142 mm.
...so con garitta per frena-
... Gkim-V delle SBB-CFF-
...wagon with brake cabin, ty-
...V of the SBB-CFF-FFS.
...so, tipo Gbs, delle S.J.
...wagon, type Gbs, of the S.J.

NEW₈₈

30 3577



...so per trasporti speciali
... con scritta.
...wagon for special transport
... of the D.B.

30 3103



CARRI REFRIGERANTI REFRIGERATOR WAGONS

Appartengono alla serie internazionale I e sono dotati di cassa ad isolamento termico, di casse e di elettroventilatori per la circolazione forzata dell'aria. Esistono nella versione a due assi (m³ 46) e in quelle a carrelli (m³ 117) e possono viaggiare sui percorsi internazionali a 100 km/h.

They belong to the International I Class, fitted with thermal insulated body, ice-boxes and roof electric fans. They feature either four wheel version (m³ 46) or bogie version (m³ 117) and can run on international routes at 62 mph.

30 3103

Carro refrigerante tipo lbcas «Interfrigo» - L. 126 mm.

Refrigerator wagon "Interfrigo", type lbcas, of the F.S. - Length 126 mm.

30 3111



30 3111

Carro refrigerante a due assi «Spatenbräu» - L. 126 mm.

2 axle refrigerator wagon "Spatenbräu", of the DB - Length 126 mm.

30 3113



30 3113

Carro refrigerante a due assi «Coca-Cola» - L. 126 mm.

2 axle refrigerator wagon "Coca-Cola", - Length 126 mm.

30 3191



30 3191

Carro refrigerante a carrelli tipo laes «Interfrigo» - L. 242 mm.

Refrigerator wagon with bogies "Interfrigo", type laes - Length 242 mm.

30 3193



30 3193

Carro refrigerante a carrelli «Weihenstephan» - L. 242 mm.

Refrigerator wagon with bogies "Weihenstephan", - Length 242 mm.

refrigerante «Findus» - L. 158
 refrigerator wagon "Findus" -
 Length 158 mm.



30 3550

refrigerante a due assi «Carlsberg» - L. 158 mm.
 refrigerator wagon "Carlsberg" -
 Length 158 mm.



30 3552

refrigerante a due assi
 "Löwenbräu" - L. 158 mm.
 refrigerator wagon "Löwenbräu"
 Length 158 mm.



30 3558

refrigerante a due assi
 "Thermos" della DB. L. 158
 refrigerator wagon "Thermos"
 of the DB.

NEW⁸⁸

30 3551



30 2931



30 2932



30 2935

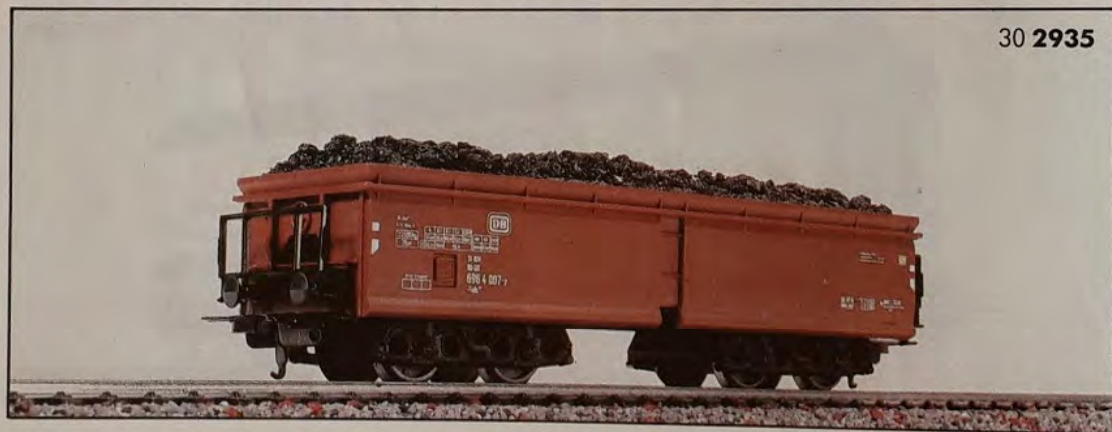

30 3578

**NEW₈₈****CARRI A TRAMOGGIA
HOPPER WAGONS**

Appartengono alla grande ripartizione internazionale dei carri di serie E a sponde alte di tipo corrente e sono atti al trasporto di minerali di basso peso specifico. Previsti per il carico dall'alto e per lo scarico automatico per gravità, a volte attraverso speciali paratoie che permettono lo scarico su entrambi i lati. Esistono nella versione a due assi come in quella a carrelli.

They belong to the international E Class and can be loaded with low-specific gravity materials. To be loaded from above and automatically unloaded by gravity, they are sometimes fitted with interior bulkheads which allow unloading on both sides. They also are available in four wheel or bogie configuration.

30 2931

Carro a tramoggia tipo Fad 167 «RAG» - L. 139 mm.
Hopper wagon «RAG», type Fad 167 - Length 139 mm.

30 2932

Carro a tramoggia tipo Fad 167 «SGW» - L. 139 mm.
Hopper wagon «SGW», type Fad 167 - Length 139 mm.

30 2935

Carro a tramoggia tipo Fads 177 delle D.B. - L. 139 mm.
Hopper wagon, type Fads 177, of the D.B. - Length 139 mm.

30 3578

Carro a tramoggia aperto tipo Eds delle SNCF, per trasporto terra - L. 110 mm.
Hopper wagon type Eds of SNCF for soil transport - Length 110 mm.

30 3579

Carro a tramoggia chiuso tipo TDS, per trasporto cereali.
Hopper wagon type Eds, for cereals transport.

**NEW₈₈**

30 3568



30 3569



30 3570



30 3571

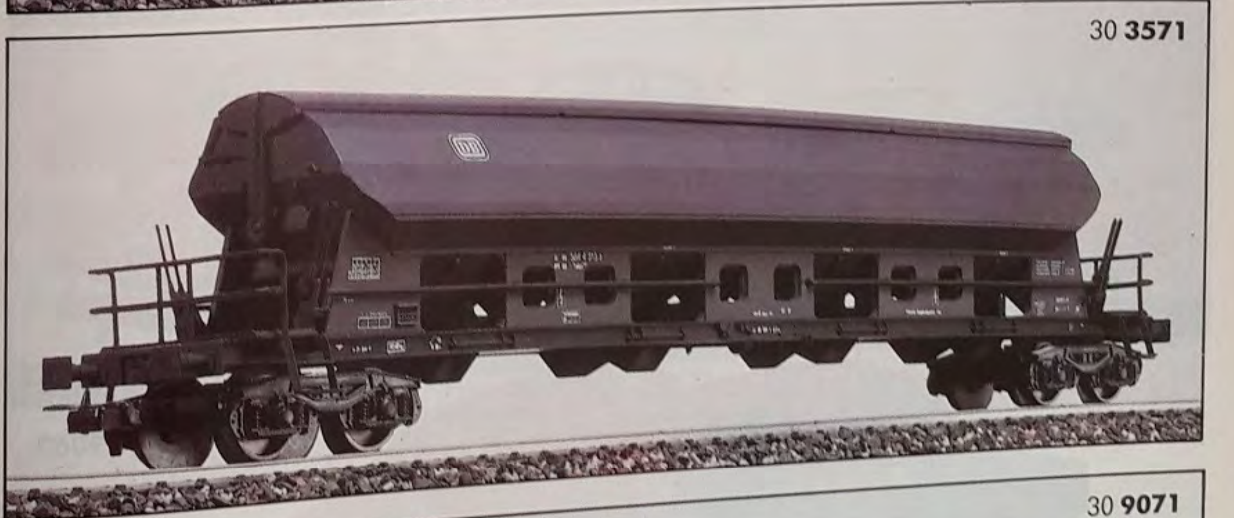

30 9071

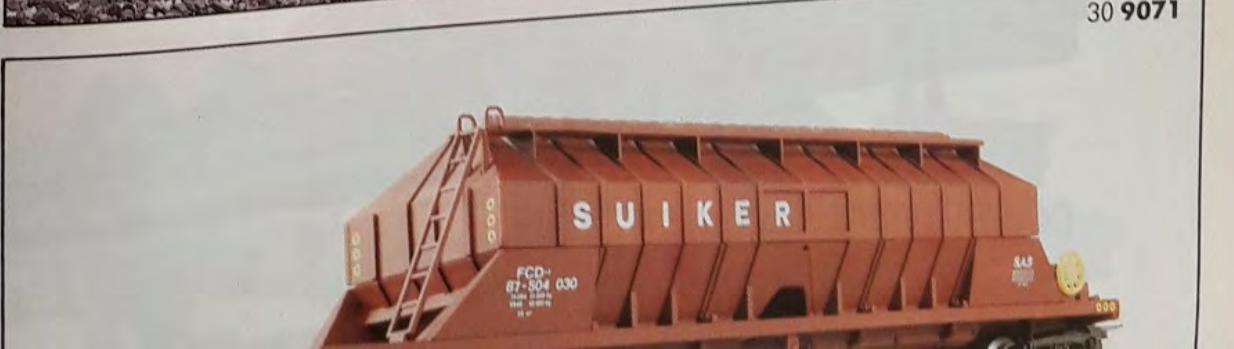

110 mm.
wagon, type Tds of the D.B. -
110 mm.

tramoggia tipo Tds delle
L 110 mm.
wagon type Tds of the
Length 110 mm.

EW 88

tramoggia tipo Tadgs⁹⁵⁹ del-
L 247 mm.
wagon, type Tadgs⁹⁵⁹ of the
length 247 mm.

EW 88

tramoggia tipo Tadgs della
L 247 mm.
wagon, type Tdags of the
length 247 mm.

tramoggia tipo FCD-2 per
zucchero delle S.A.R. - L.
wagon, type FCD-2, for the
of sugar, of the S.A.R. -
110 mm.

30 2860



CARRI CON TELONE WAGONS WITH TARPAULINS

Sono i carri pianali a sponde basse della serie L e R, sui quali vengono posti teloni a protezione del carico oppure vengono predisposti con terminali fissi fra i quali viene fatta scorrere una centinata munita di telone. Sono lunghi dai 13,9 ai 19,9 metri e sono a due o a quattro assi. They are the international L and R Class flat wagons, which are fitted with protective tarpaulins spread on the loaded goods or with two rigid end bulkheads and in-between sliding tarpaulin mounted on a steel structure. They are 46 to 65 feet long, according to their four wheel or bogie configuration.

30 3178



30 2860

Carro con telone tipo Rils «Vittel» - L. 227 mm.

Wagon with tarpaulin, type Rils "Vittel" - Length 227 mm.

30 3178

Carro con telone a due assi. «Volkswagen-Audi» - L. 121 mm.

2 axle wagon with tarpaulin "Volkswagen-Audi" - Length 121 mm.

30 9035



NEW₈₈

30 9035

Vagone con telone «Danzas» - L. 206 mm.

Wagon with tarpaulin "Danzas" - Length 206 mm.

30 9063

30 9063

Carro trasporto auto su due piani «Goth» - L. 290 mm.

Wagon "Goth" for car transport at two levels - Length 290 mm.



... dei carri piani...
 ... a due, tre oppure...
 ... volte a pianale ribas-
 ... idonei a viaggiare ag-
 ... passeggeri. Dispon-
 ... piani di carico sovrappo-
 ... limite di carico di 19

... to the international spe-
 ... wagons, in four or six
 ... version. They some-
 ... lowered loading plat-
 ... a 19-tons load limit.
 ... be attached to passenger

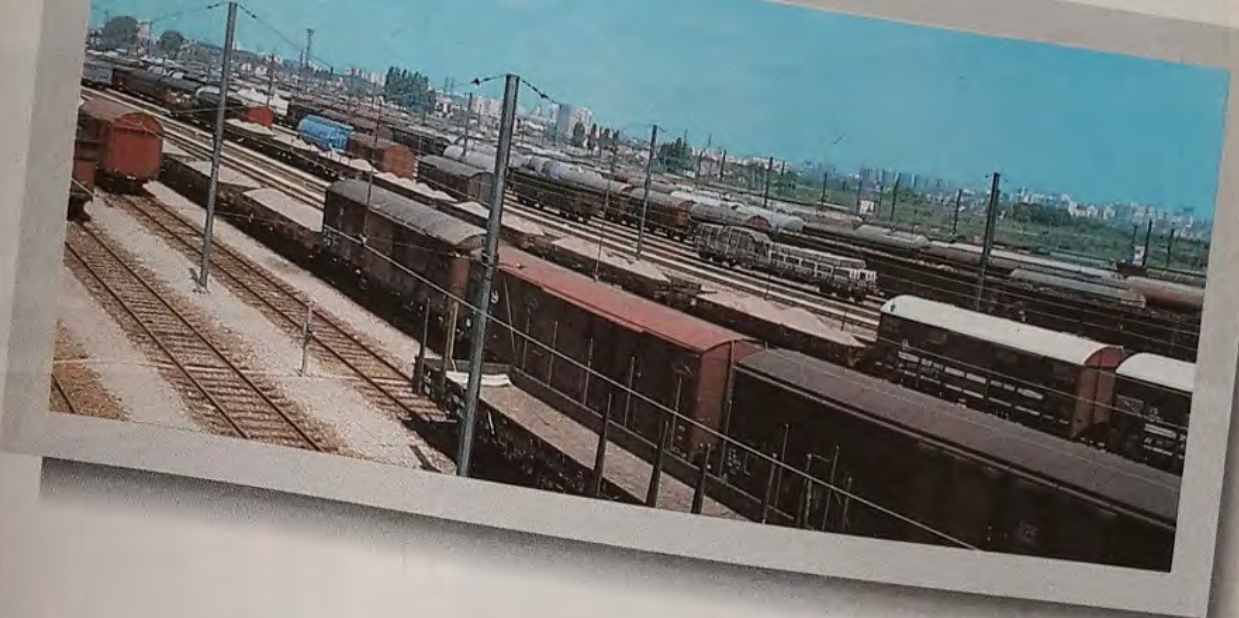

... porto auto su due piani, ti-
 ... delle D.B. - L. 125 mm.
 ... of two levels, type La-
 ... D.B. - Length 125 mm.



30 3573

... porto auto su due piani, ti-
 ... S.T.F.A. - L. 290 mm.
 ... S.T.F.A. for car transport,
 ... type Laes - Length 290



30 9050

... porto auto su due piani, ti-
 ... delle D.B. - L. 280 mm.
 ... car transport, at two le-
 ... of the D.B. -



30 9060

30 3181



30 3187



30 3188



30 2832



30 2833



**CARRI A PORTE
SCORREVOLI E A TETTO
APRIBILE
WAGONS WITH SLIDING
DOORS AND REMOVABLE
TOPS**

I primi costituiscono allestimenti speciali sui carri serie H e serie G, sui quali figurano porte o intere fiancate scorrevoli per facilitare le operazioni di carico/scarico di merci di notevole ingombro. I secondi sono classificati come carri di serie T, sui quali il tetto è ribaltabile lateralmente (Taes) oppure è del tipo a serranda avvolgibile (Ts). Sono idonei a viaggiare a 100 km/h.

The first ones belong to the international H and G Classes, which are fitted with special sliding doors or sides for ease of loading and unloading operations of cumbersome goods. The second ones are classified as T Class wagons, which are fitted with pivoting roof (Taes wagon) or with rolling roof (Ts wagon). Suitable to run at 62 mph.

30 3181

Carro chiuso a tetto apribile, tipo Ts, delle D.B. - L. 161 mm.
Closed wagon with opening top, type TS, of the D.B. - Length 161 mm.

30 3187

Carro chiuso a tetto apribile, tipo Taes, delle S.N.C.F. - L. 160 mm.
Closed wagon with opening top, type Taes, of the S.N.C.F. - Length 160 mm.

30 3188

Carro chiuso ad apertura telescopica, tipo Shimms, delle ferrovie Federali Svizzere SBB-CFF-FFS - L. 132 mm.
Closed wagon with telescopic opening, type Shimms, of the SBB-CFF-FFS - Length 132 mm.

30 2832

Carro trasporto trucioli, tipo Fb-u, delle S.J. - L. 130 mm.
Wagon for the transport of turnings, type Fb-u, of the S.J. - Length 130 mm.

30 2833

Carro trasporto trucioli, tipo Fby della D.B. - L. 130 mm.
Wagon for the transport of turnings, type Fby, of the D.B. - Length 130 mm.

NEW₈₈

30 3207



Wagon a porte scorrevoli,
 della CFF.
 Wagon with sliding doors, ty-
 pe of the CFF.



W88

Wagon a porte scorrevoli, a 2 assi,
 della ÖBB - L. 160 mm.
 Wagon with sliding doors, type Hbis
 ÖBB - Length 160 mm.



30 3565

Wagon a porte scorrevoli, tipo
 della D.B. - L. 160 mm.
 Wagon with sliding doors, ty-
 pe of the D.B. - Length 160



30 3566

Wagon a porte scorrevoli, tipo
 della FS - L. 242 mm.
 Wagon with sliding doors, ty-
 pe of the FS - Length 242

Wagon a porte scorrevoli, tipo
 della S.N.C.F. - L. 242 mm.
 Wagon with sliding doors, ty-
 pe of the S.N.C.F. - Length

30 3205



30 3198



30 3198
Carro chiuso a porte scorrevoli tipo Habis, «Franprix» - L. 242 mm.
Closed wagon "Franprix" with sliding doors, type Habis - Length 242 mm.

30 3200
Come articolo 30 3198 ma con scritte «EVS».
As item 30 3198 but with "EVS" inscriptions.

30 9049



NEW₈₈

30 9049
Carro articolato per trasporto ghisa - L. 220 mm.
Articulated foundry wagon - Length 220 mm.

CARRI PER TRASPORTI SPECIALI
TROLLEY WAGONS

Sono carri pianali a due assi a bilico serie L, oppure carri serie U con piano di carico ribassato, dotati di due, quattro, fino a quattordici assi. La portata varia da 30 a 183 tonnellate; in quest'ultimo caso si tratta di carri atti a carichi eccezionali per ingombro e peso. La lunghezza massima fuori respingenti arriva a 32,4 metri.

They are articulated wagons belonging to the international L Class or to the U Class with lowered loading platform, fitted with two to fourteen axles. The payload varies from 30 to 183 tons and the overall length ranges up to 106 feet. They are sometimes used for exceptionally cumbersome and heavy load transportation.



... delle S.N.C.F. - L.
... stakes, type Roos, for
... of timber, of the
... length 227 mm.

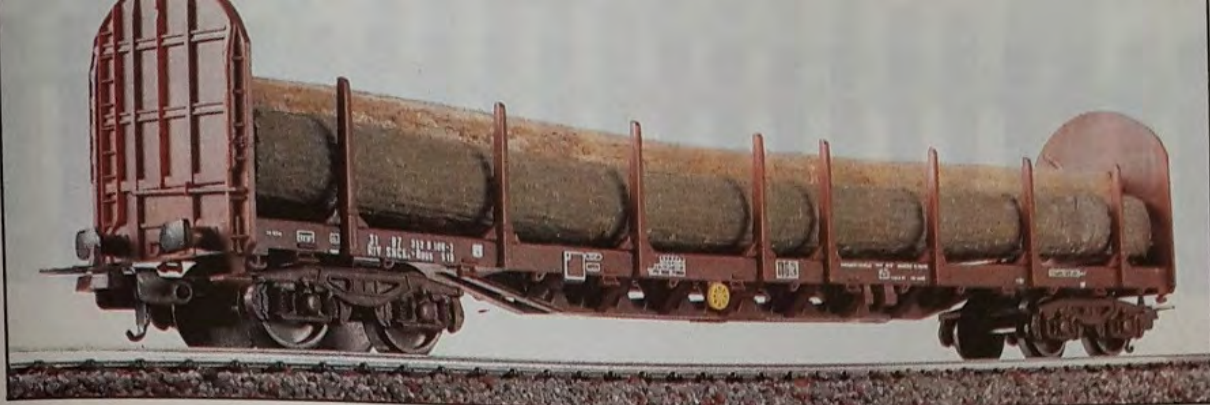

... ribassato delle D.B. -
... lowered flat, of the
... 230 mm.



30 9080

... composto da carro-gru e
... di appoggio delle
... mm.
... crane with open wa-
... D.B. - Length 260 mm.



30 9059

NEW⁸⁸

CONFEZIONI COMPLEMENTARI ADDITIONAL TRACK LAYOUTS

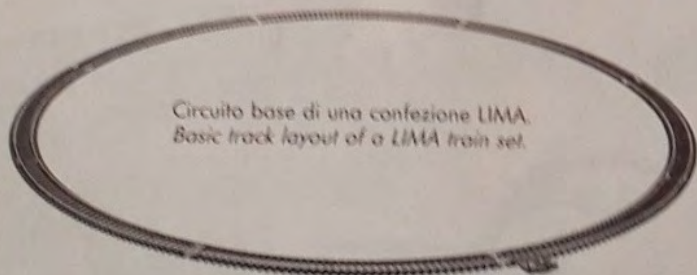

Circuito base di una confezione LIMA.
Basic track layout of a LIMA train set.

Le confezioni dei binari LIMA sono predisposte in modo da consentire fin dall'inizio la posa in opera di un tracciato elementare e, attraverso l'impiego delle scatole complementari, di proseguire per stadi successivi fino alla composizione di tracciati ferroviari sempre più complessi. È questa la fase in cui viene richiesto al modellista il maggior grado di creatività, in funzione dello spazio disponibile e delle preferenze di ognuno. LIMA interviene appunto con le sue confezioni di binari e scambi per facilitare il compito e per valorizzare lo spirito di inventiva di quanti si accingono a costruire un tracciato o un plastico ferroviario completo. Il sistema LIMA di confezioni complementari è costituito di serie di binari dritti e curvi nonché di scambi e incroci, che si integrano a vicenda affinché da un tracciato base si possa passare a circuiti composti, sui quali possa marciare quindi non soltanto un treno ma più convogli, come nella realtà.

LIMA track extension sets are designed to add to the construction of the first basic circular layout and with further track extension sets, a more complex railway layout. This stage requires a very high level of creativity, according to the available space and to the various needs of the modeller. This is the reason why LIMA offer different sets composed of track sections and points in order to make the modeller's task easier and to better exploit their imagination. The LIMA system of track extension sets consists of various progressive combinations of straight and curved track, points and crossing, through which a basic layout can be expanded into a complete layout allowing, as in real life, the simultaneous running of more than one train.

A+B

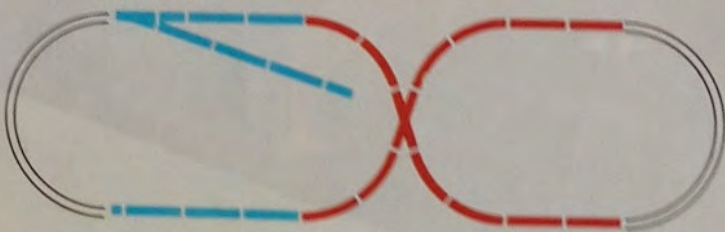

A+C



B+C



LA FUNZIONAMENTO MANUALE / HAND OPERATING POINTS

di binari e di scambi a funzionamento
 predisposte per procedere a stadi succes-
 sivamente, alla fine, di poter posare un cir-
 cuito modellistico. Tutti i circuiti comple-
 ti sono compatibili, fino a formare trac-
 ciate complesse e di grandi dimensioni.
 extension sets, consisting of track sec-
 tion operating points, are designed to allow
 the construction of a railway layout, up to
 a large system. Each LIMA track extension set
 is compatible with the others to form an integrated sy-
 stem of realistic model railway.

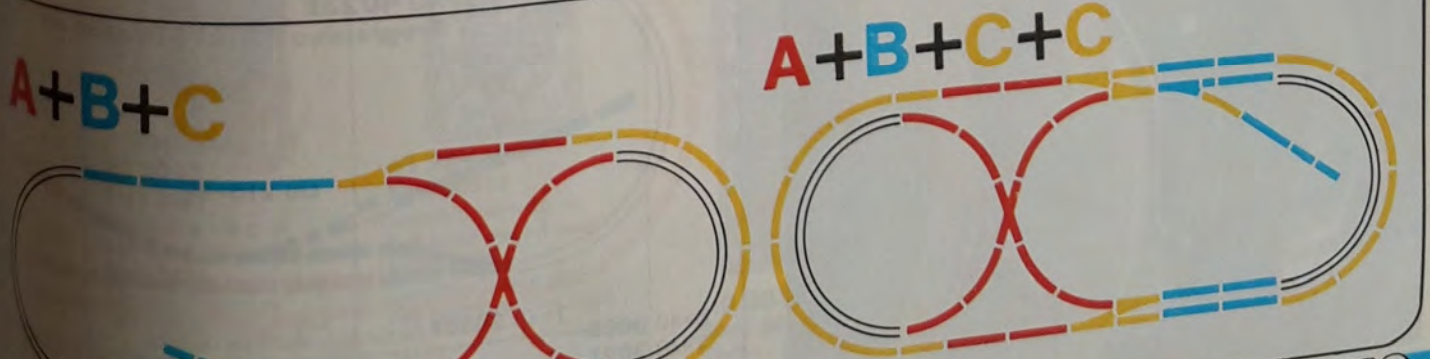
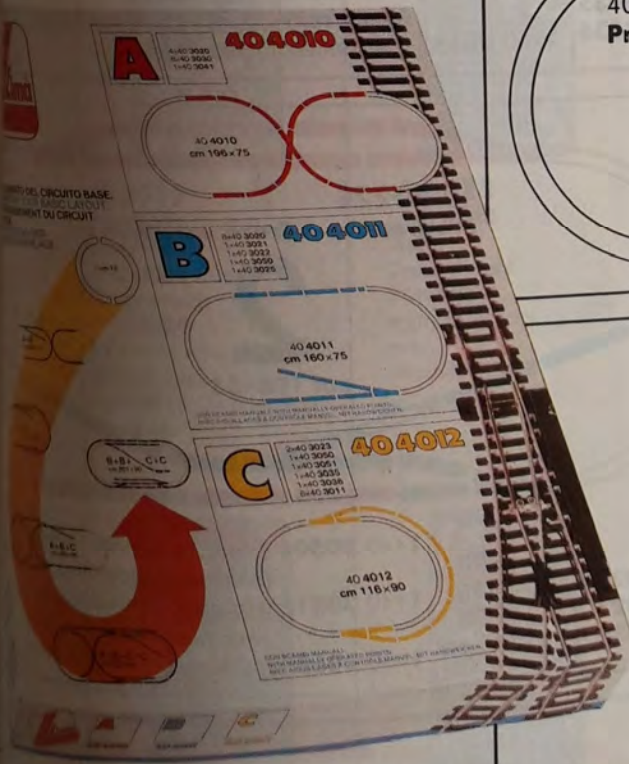
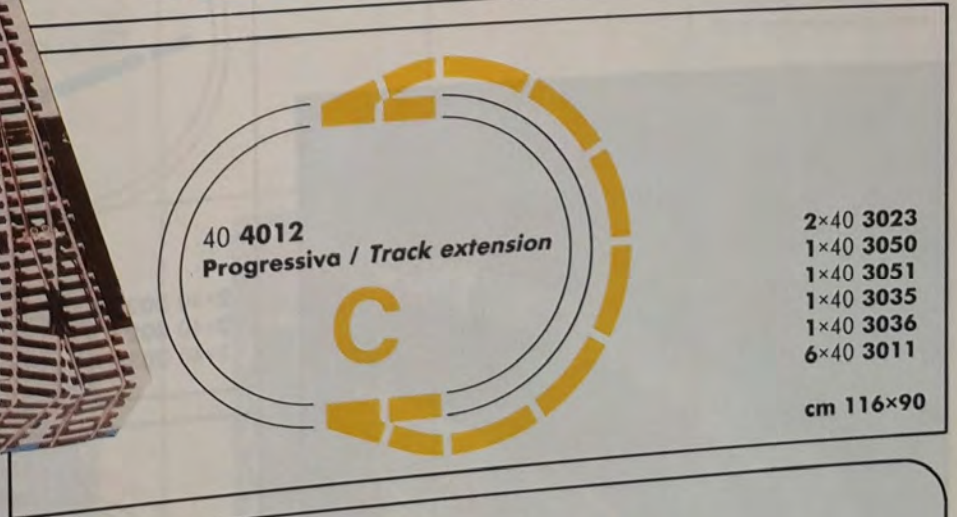
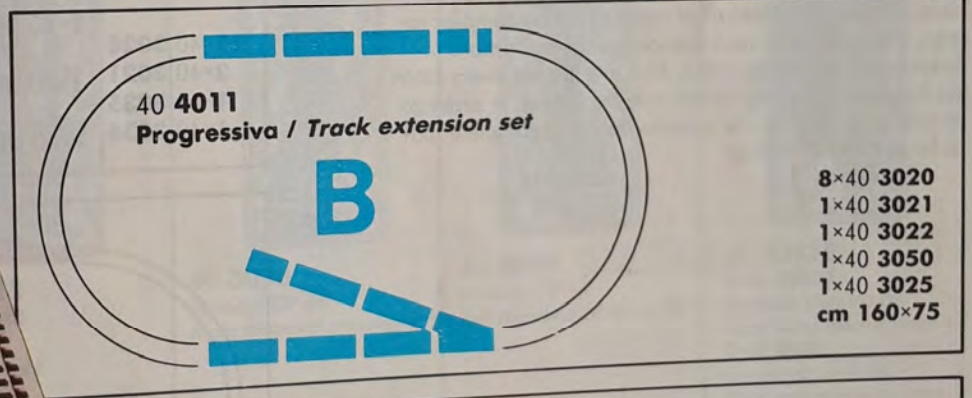
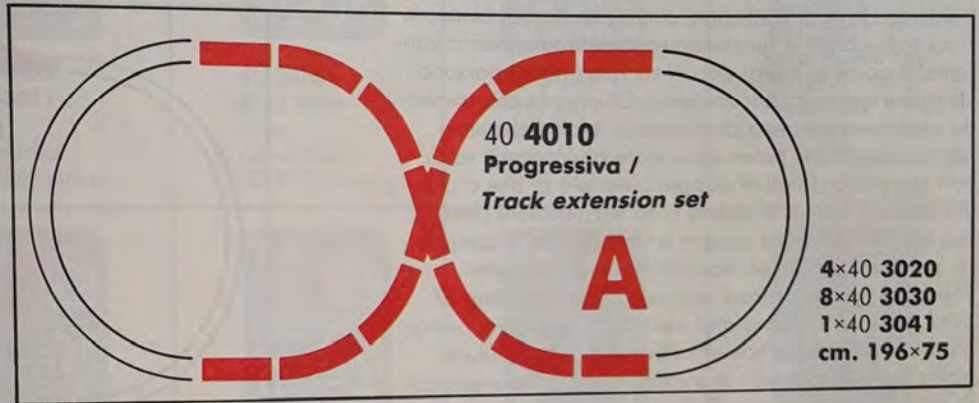

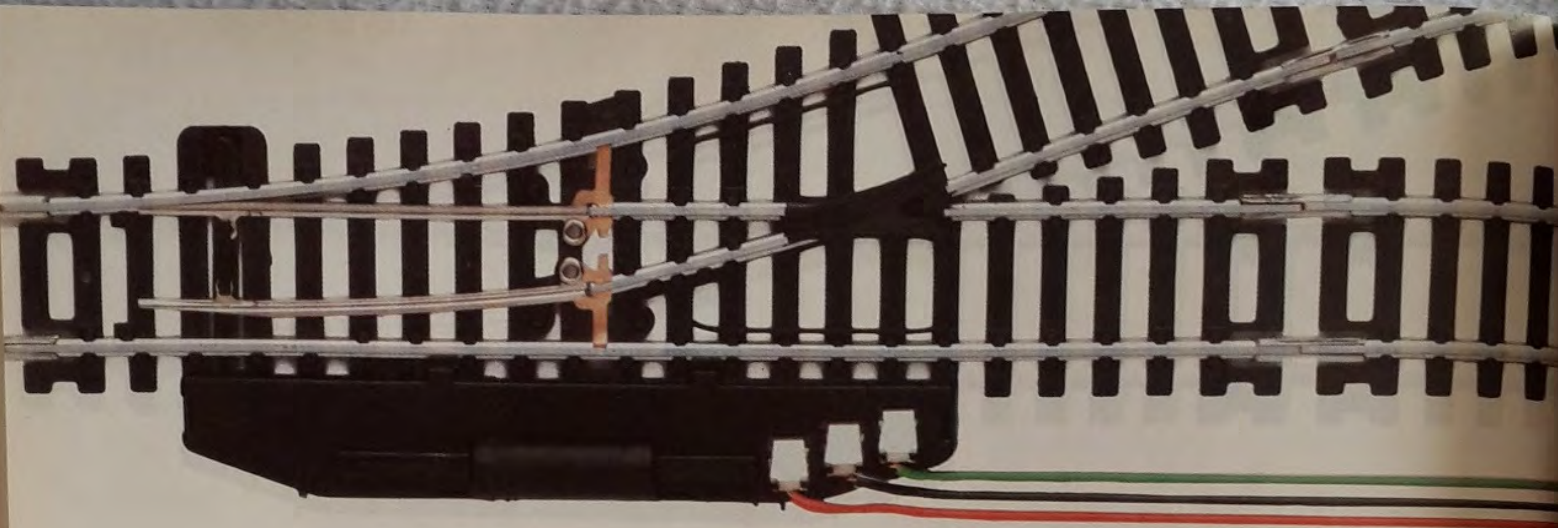

SCAMBI A FUNZIONAMENTO ELETTRICO / ELECTRICALLY OPERATING POINTS

Il sistema LIMA di confezioni complementari di binari, incroci e di scambi a funzionamento elettromagnetico consente di porre in opera circuiti sui quali i treni possono viaggiare con maggior realismo. Gli scambi con comando elettrico a distanza costituiscono infatti l'elemento fondamentale per poter manovrare più convogli su circuiti complessi dotati di doppio binario e di due o più intersezioni. Anche in questo caso le confezioni LIMA con scambi elettrici si integra a vicenda fino a comporre, per stadi successivi, tracciati ferroviari completi.

The LIMA system of track extension sets, consisting of track sections, crossing and electrically-operating points, enables the construction of railway layouts on which trains can operate with a greater realism. The electrically-operating points actually represent the basic components allowing the control of more trains on complex layouts where double track sections and two or more intersections are configured. Also in this case every LIMA set is designed to fully match with the others, in order to ensure, step by step, the construction of a complete modular miniature railway.

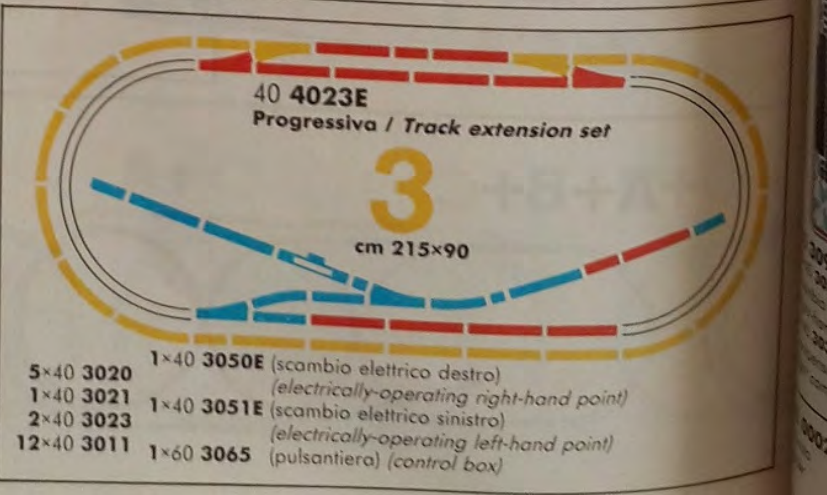
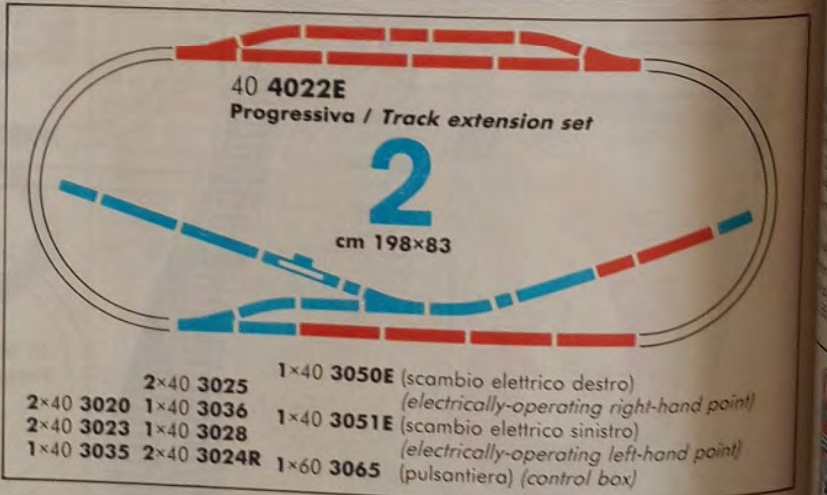
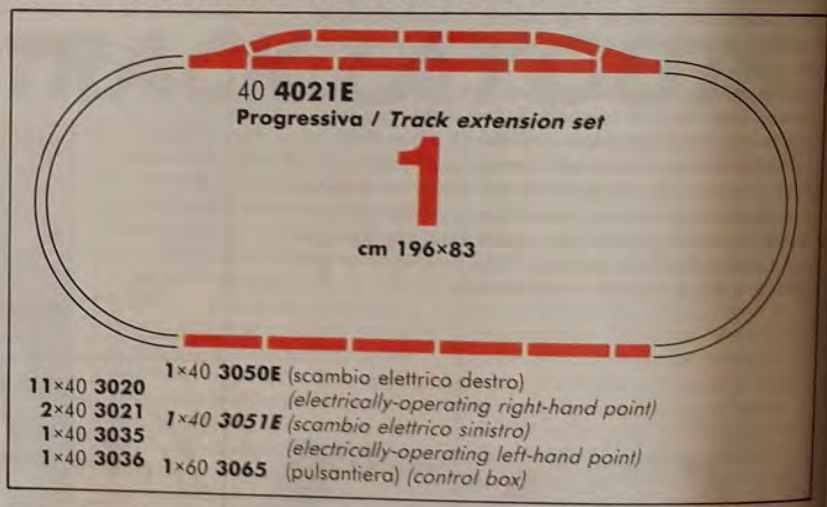

BINARI - TRACK



40 3072
6x40 3023
 diritto
 straight track
 L. 166,5 mm



40 3086
6x40 3011
 curvo
 curved track
 30° Ø862 mm.



40 3084
6x40 3034
 curvo
 curved track
 30° Ø 720 mm.



40 3087
6x40 3012
 curvo
 curved track
 22° Ø 862 mm.



40 3085
4x40 3031
 curvo curved track
 18° Ø 720 mm.
4x40 3032
 curvo curved track
 9° Ø 720 mm.



40 3089
4x40 3021 Diritto
 Straight-track
2x40 3022 Diritto
 Straight-track
1x40 3024
 Diritto con attacco corrente
 Straight-track
1x60 0015 Giunti isolati
 Power clip



40 3078
1x40 3020
 Diritto
 Straight track
1x40 3028
 Sgancia vagoni - L. 222
 mm.
 Uncoupler



40 3098
 Incrocio 18° dx.
 Right diamond crossing 18°



40 3099
 Incrocio 18° sx.
 Left diamond crossing 18°



40 3092E
1x40 3050E
 Scambio elettrico dx.
 Right hand electric point.
1x40 3035
 Compensazione dx.
 Right compensating track.



40 3093
1x40 3051
 Scambio a mano sx.
 Left-hand manual point
1x40 3036
 Compensazione sx.
 Left compensating track



40 3093E
1x40 3051E
 Scambio elettrico dx.
 Left hand electric point
1x40 3036
 Compensazione dx.
 Left compensating track



40 3073
6x40 3027
 Diritto - L. 333 mm.



40 3083
6x40 3017
 Curvo 45° Ø 862 mm.
 Curved track



40 3088
6x40 3029
 Curvo 45° Ø 720 mm.
 Curved track

GEOMETRIA GEOMETRY

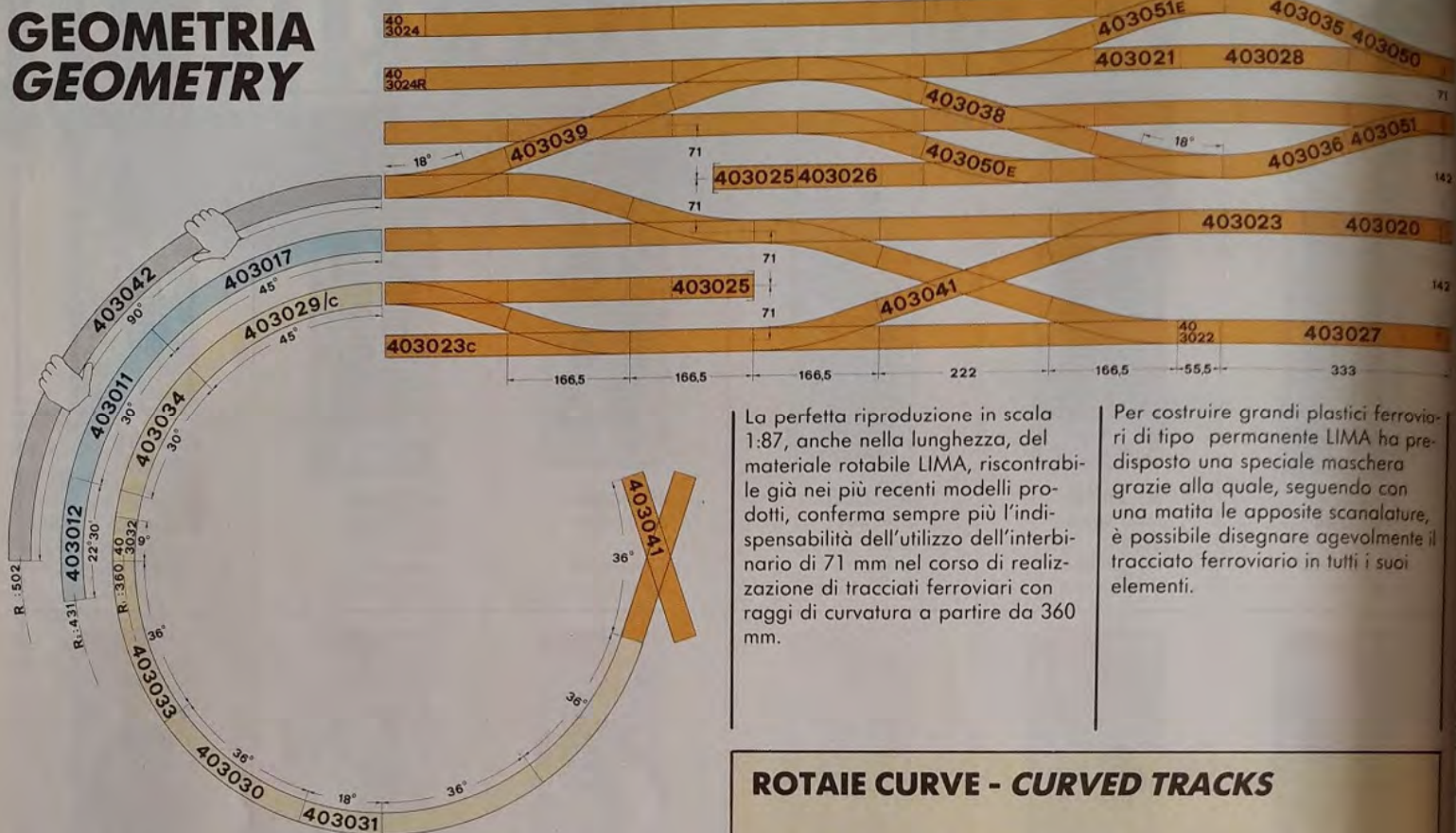

La perfetta riproduzione in scala 1:87, anche nella lunghezza, del materiale rotabile LIMA, riscontrabile già nei più recenti modelli prodotti, conferma sempre più l'indispensabilità dell'utilizzo dell'interbinario di 71 mm nel corso di realizzazione di tracciati ferroviari con raggi di curvatura a partire da 360 mm.

Per costruire grandi plastici ferroviari di tipo permanente LIMA ha predisposto una speciale maschera grazie alla quale, seguendo con una matita le apposite scanalature, è possibile disegnare agevolmente il tracciato ferroviario in tutti i suoi elementi.

BINARI DIRITTI / STRAIGHT TRACKS

40 3027
Diritto L. 333 mm - Conf. 12 pz.
Straight L. 333 mm. - box 12 pcs.

40 3020
Diritto L. 222 mm - Conf. 12 pz.
Straight L. 222 mm. - Box 12 pcs.

40 3023
Diritto L. 166,5 mm - Conf. 12 pz.
Straight L. 166,5 mm - Box 12 pcs.

40 3023C
Diritto con attacco corrente L. 166,5 mm - Conf. 12 pz.
Straight with power clip L. 166,5 mm. - Box 12 pcs.

40 3021
Diritto L. 111 mm - Conf. 12 pz.
Straight L. 111 mm. - Box 12 pcs.

40 3025
Terminale L. 111 mm - Conf. 6 pz.
Buffer stop L. 111 mm. - Box 6 pcs.

40 3024
Diritto con attacco corrente L. 55,5 mm - Conf. 12 pz.
Straight with power clip L. 55,5 mm - Box 12 pcs

40 3024R
Diritto con interruzione unipolare e contatto L. 55,5 mm - Conf. 12 pz.
Straight isolating L. 55,5 mm - Box 12 pcs.

40 3022
Diritto L. 55,5 mm - Conf. 12 pz.
Straight L. 55,5 mm - Box 12 pcs.

ROTAIE CURVE - CURVED TRACKS

40 3029
Curvo Ø 720 mm 45° - Conf. 12 pz.
Curved Ø 720 mm 45° - Box 12 pcs.

40 3029C
Curvo Ø 720 mm 45° con attacco di corrente. Conf. 12 pz.
Curved Ø 720 mm 45° with power clip - Box 12 pcs.

40 3030
Curvo Ø 720 mm 36° - Conf. 12 pz.
Curved Ø 720 mm 36° - Box 12 pcs.

40 3034
Curvo Ø 720 mm. 30° - Conf. 12 pz.
Curved Ø 720 mm 30° - Box 12 pcs.

40 3031
Curvo Ø 720 mm 18° - Conf. 12 pz.
Curved Ø 720 mm 18° - Box 12 pcs.

40 3032
Curvo Ø 720 mm 9° - Conf. 12 pz.
Curved Ø 720 mm 9° - Box 12 pcs.

40 3012
Curvo Ø 862 mm 22° - Conf. 12 pz.
Curved Ø 862 mm 22° - Box 12 pcs.

40 3011
Curvo Ø 862 mm 30° - Conf. 12 pz.
Curved Ø 862 mm 30° - Box 12 pcs.

40 3017
Curvo Ø 862 mm 45° - Conf. 12 pz.
Curved Ø 862 mm 45° - Box 12 pcs.

youis, LIMA manufactured a special track planning stencil and, by following the grooves with a pencil, you can easily plan all aspects of your intended railway track.

one dello scambio. With the new LIMA isolated point, one may easily isolate section of the layout. The traction current is fed to

SCAMBI ISOLATI ISOLATED POINTS

Con il nuovo scambio isolato LIMA, ottenibile sezionando i contatti posti al di sotto dello stesso come in figu-



DA 100 PEZZI OF 100 PCS

40 3067

curvo \varnothing 720 mm 36°
(100x40 3030)
curved \varnothing 720 mm 36°

40 3058

Curvo \varnothing 720 mm
30°
(100x40 3034)
Curved \varnothing 720 mm
30°

40 3068

Diritto L. 166,5
mm.
(100x40 3023)
Straight L. 166,5
mm.

40 3060

Diritto L. 222 mm
(100x40 3020)
Straight L. 222
mm.

40 3057

Diritto L. 333
mm
(100x40 3027)
Straight L. 333
mm

INCROCI - CROSSINGS

40 3041

Incrocio a 36° - Conf. 2 pz.
Diamond crossing 36° - Box 2 pcs.

40 3038

Incrocio dx a 18° - Conf. 2 pz.
Right diamond crossing 18° - Box 2 pcs.

40 3039

Incrocio sx a 18° - Conf. 2 pz.
Left diamond crossing 18° - Box 2 pcs.

RICAMBI SPECIALI - SPECIAL TRACK

40 3033

Rerailer \varnothing 720 mm 36° - Conf. 12 pz.
Rerailer \varnothing 720 mm 36° - Box 12 pcs.

40 3028

Sgancia vagoni - L. 222 mm. - Conf. 6 pezzi.
Uncoupler L. 222 mm. - Box 6 pcs.

40 3026

Allungabile da 111 a 166,5 mm - Conf. 6 pz.
Extensible L. 111 to 166.5 mm - Box 6 pcs.

SCAMBI - POINTS



40 3050

Scambio a mano dx - Conf. 2 pz.
Right-hand manual point - Box 2 pcs.



40 3051

Scambio a mano sx - Conf. 2 pz.
Left-hand manual point - Box 2 pcs.



40 3050E

Scambio elettrico dx. - Conf. 2 pz.
Right-hand electric point - Box 2 pcs.



40 3051E

Scambio elettrico sx. - Conf. 2 pz.
Left-hand electric point - Box 2 pcs.

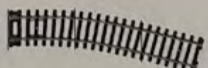

40 3035

Compensazione dx. dello scambio -
Conf. 12 pz.
Right compensating point - Box 12 pcs.



40 3036

Compensazione sx. dello scambio - Conf.
12 pz.
Left compensating point - Box 12 pcs.

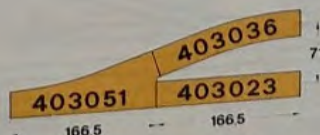

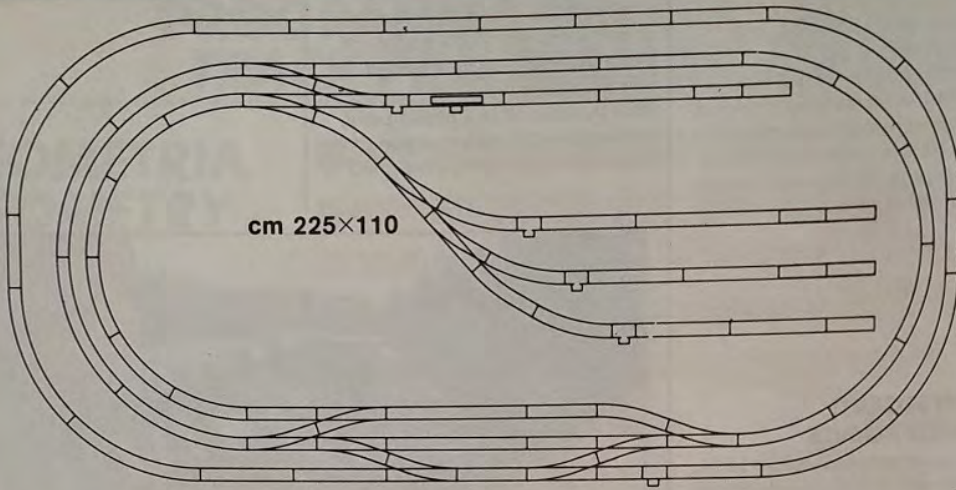

cm 225×110

1×40 3073
2×40 3070
4×40 3076
1×40 3078

2×40 3084
1×40 3086
2×40 3083
1×40 3089

6×40 3092
6×40 3093
1×60 3065
1×40 3072

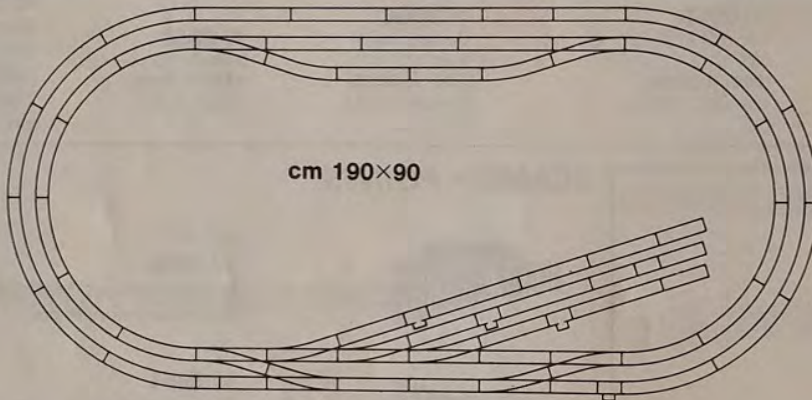

cm 190×90

3×40 3076
3×40 3092
1×40 3089

1×40 3070
2×40 3072

2×40 3086
2×40 3084

6×40 3093
1×40 3065

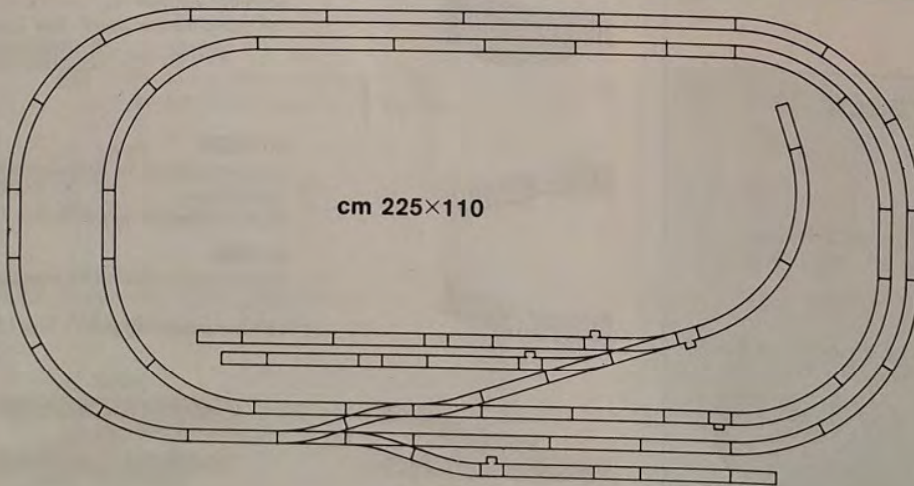

cm 225×110

2×40 3086
2×40 3088
1×40 3072

1×40 3089
3×40 3093
1×60 3065

1×40 3073
3×40 3092

4×40 3076
2×40 3070



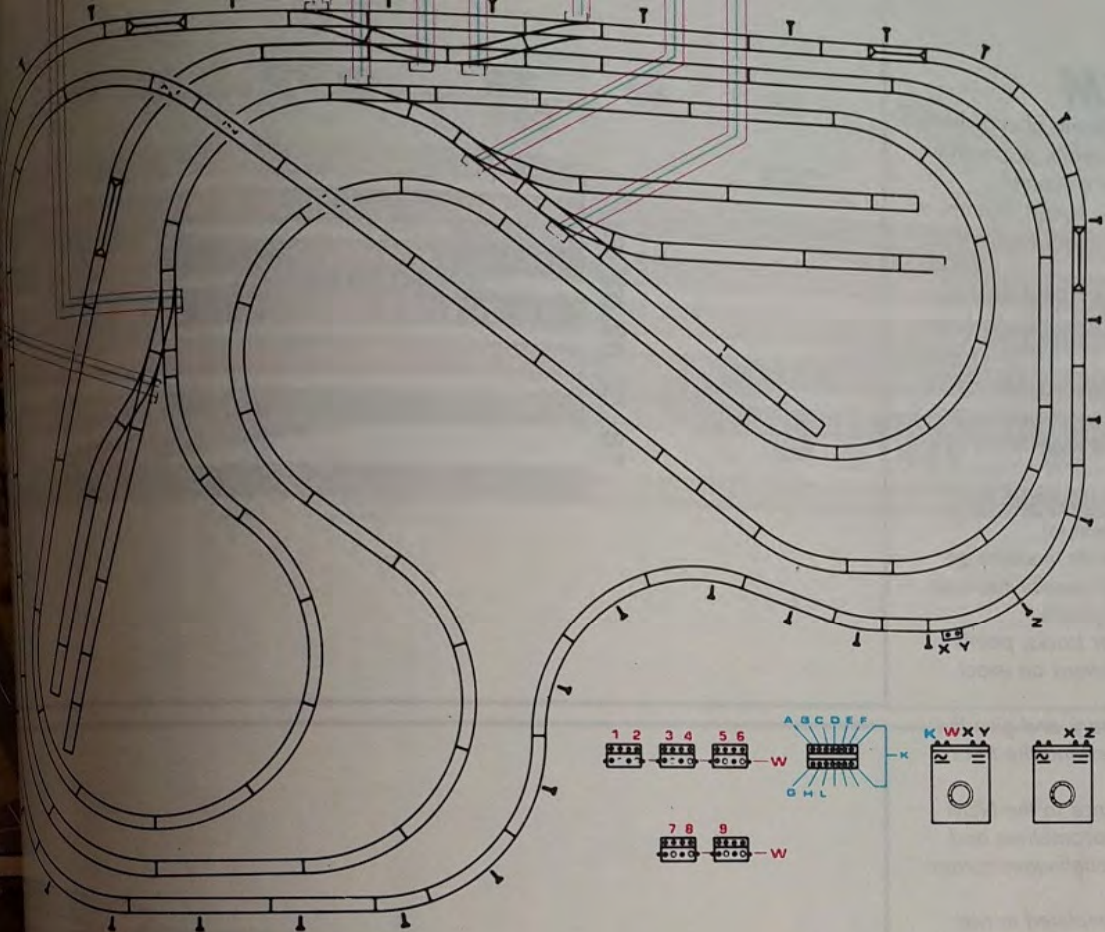

- 5×40 3021
- 4×40 3022
- 5×40 3023
- 5×40 3025
- 4×40 3026
- 25×40 3027
- 6×40 3017
- 42×40 3030
- 1×40 3030C
- 12×40 3031
- 1×40 3033
- 1×40 3035
- 4×40 3050
- 4×40 3051
- 1×60 2952
- 16×60 2950
- 17×60 2951
- 24×60 2961
- 7×60 2960
- 3×60 2962
- 5×60 3065
- 1×60 3066
- 2×60 2060

cm 200×275

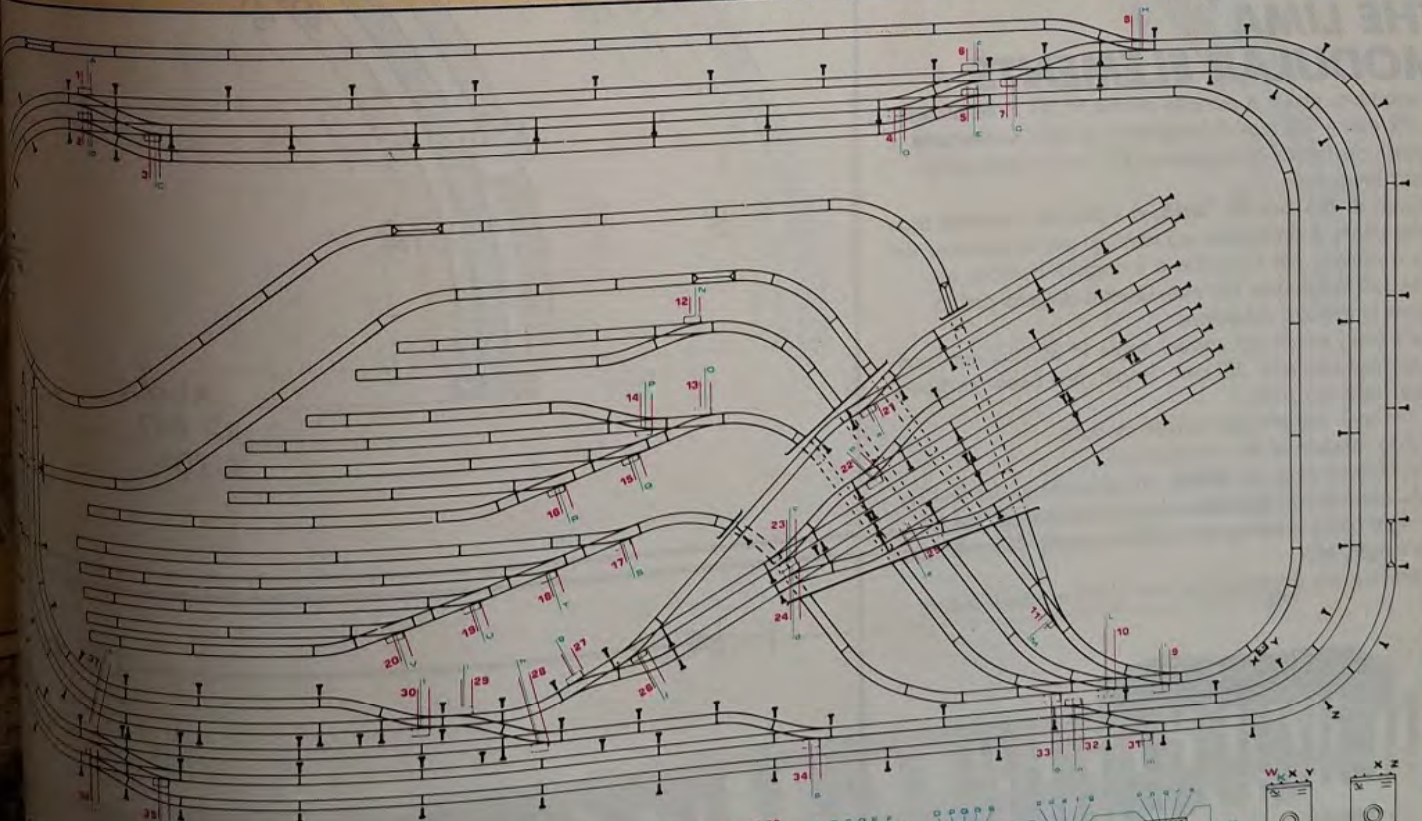

440×190

- 1 2
- 3 4
- 5 6
- 7 8
- 9 10
- 11 12
- 13 14
- 15 16
- 17 18
- 19 20
- 21 22
- 23 24
- 25 26
- 27 28
- 29 30
- 31 32
- 33 34
- 35 36
- 37 38
- 39 40

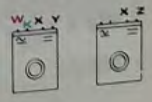
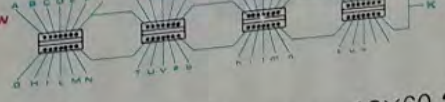

- 121×40 3027
- 18×40 3017
- 9×40 3035
- 9×40 3036
- 28×40 3050
- 2051E
- 4×60 3066
- 2×60 2060
- 78×60 2950
- 18×60 2951
- 12×60 2953
- 10×60 2954
- 1×60 2952
- 88×60 2962
- 40×60 2961
- 58×60 2960

IL NUOVO SISTEMA MODULARE LIMA

THE NEW LIMA MODULAR SYSTEM

Il nuovo programma di binari LIMA, grazie al suo sistema modulare, offre un numero incalcolabile di possibilità di combinazioni individuali di binari e scambi.

Con un sistema completo di moduli per binari, scambi e incroci, si possono costruire stazioni in scala esatta e in poco spazio.

Gli elementi dei moduli sono complementari e offrono la possibilità in ogni momento di modificare e ingrandire il circuito dei binari.

Gli elementi modulari sono conformi alle norme NEM e permettono la circolazione di tutte le locomotive e carrozze in scala 1:87 nel sistema corrente continua a 2 rotaie.

Il nuovo sistema di binari LIMA sarà completato in 2 anni e avrà ulteriori aggiunte nel frattempo.

The new LIMA track program, through its modular system, offers an incalculable number of possibilities and individual combinations of tracks and points.

With a complete system of modules for tracks, points and crossings it is possible to build stations on exact scale and minimum space.

The module elements are complementary and give the possibility at any time to modify and extend the track circuit.

The modular elements are in accordance with the NEM rules and allow the circulation of all locomotives and coaches on scale 1:87 in the two rail continuous current system.

The new LIMA track system will be completed in two years and in the meantime will have further additions.

GLI ELEMENTI MODULARI LIMA

THE LIMA MODULAR ELEMENTS

Lo scambio, che è a perfette norme 9° 30', interbinario da 52 mm e 310 mm di lunghezza, è stato **sezionato** in 2 parti: deviatore di lunghezza 155 mm - cuore della stessa lunghezza.

Il cuore di 155 mm, 40 3845, che diventa il **primo modulo** LIMA, è simmetrico ed identico per lo scambio destro o sinistro, per l'incrocio o il doppio incrocio, anch'essi di lunghezza 155 mm. Questa diventa così la nuova lunghezza modulare.

The point, which are correct angle 9° 30', 52 mm scale six-foot way and 310 mm length, has been "sectionalized" into two parts:

- 155 mm length point blade module
- frog module of the same length

The 155 mm frog, 40 3845, which becomes the first LIMA "module", is symmetrical and identical for the left or right point, crossing or double crossing 155 mm. Same length, too.

Therefore this becomes the new LIMA modular length.



40 3830E



40 3845

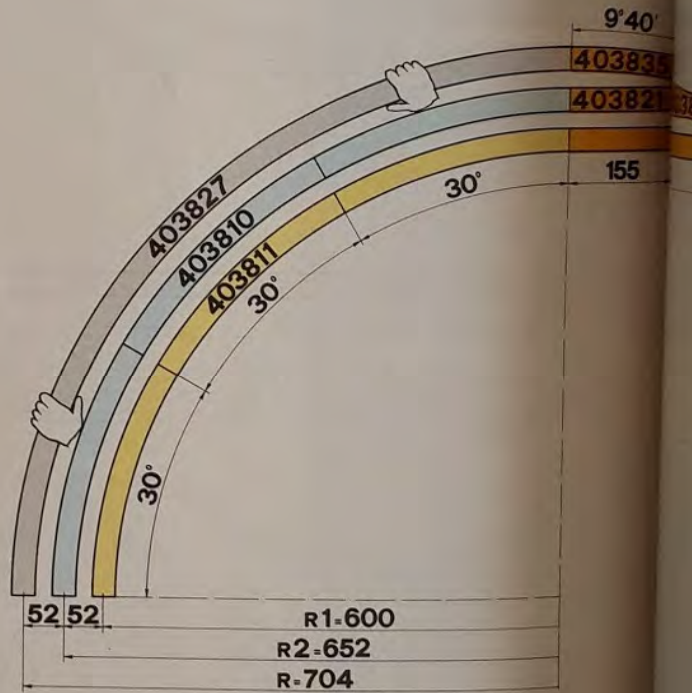
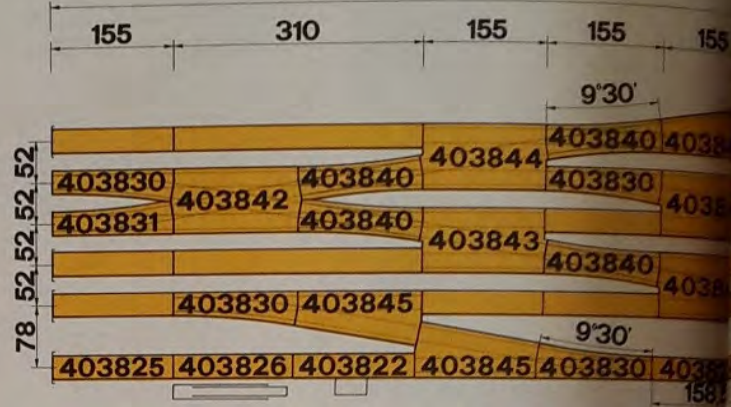

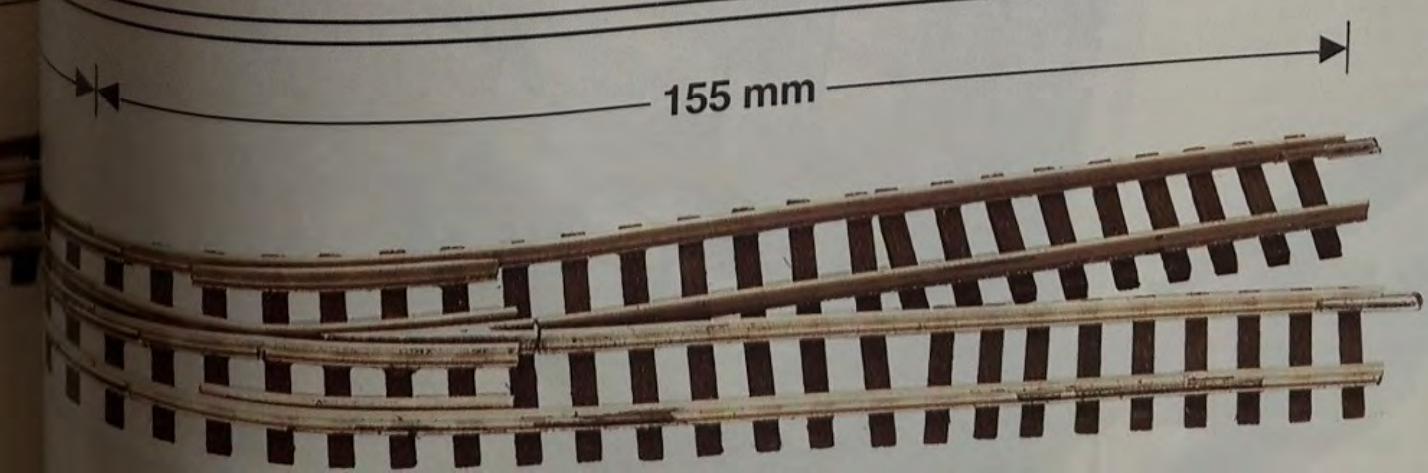
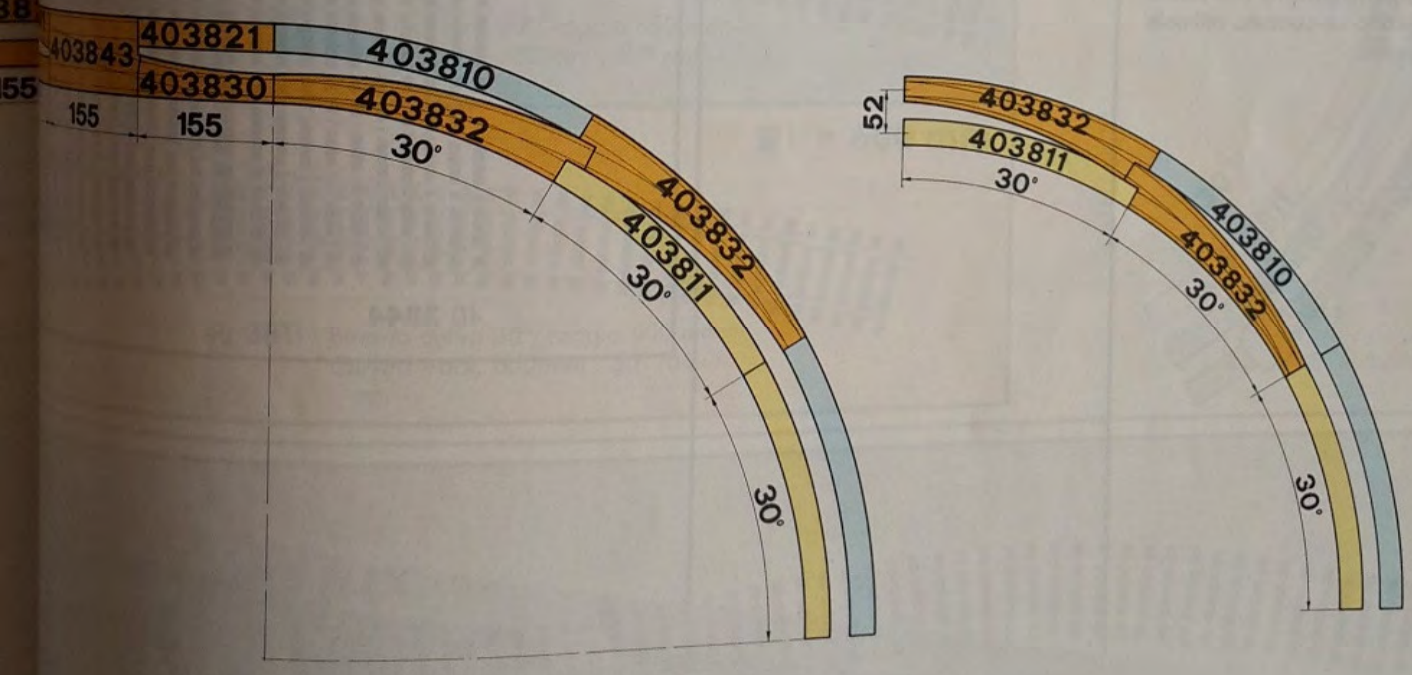
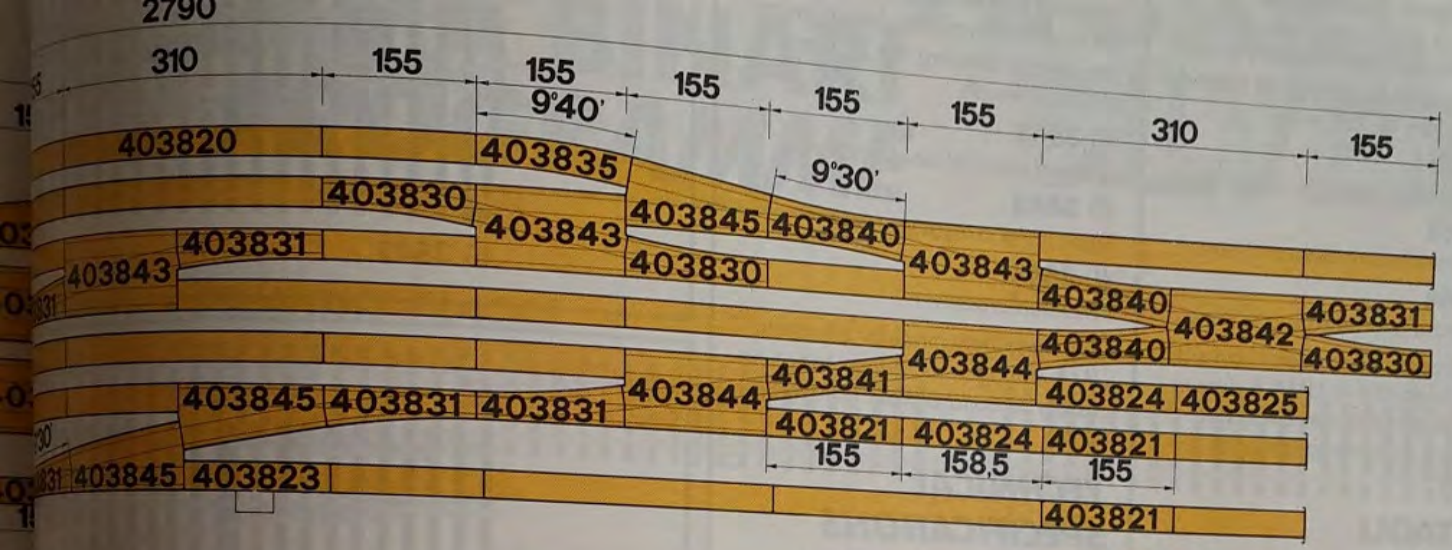

L'introduzione di **3 nuovi elementi modulari** fondamentali per i tracciati ferroviari abbinati agli elementi scambio e incroci permettono di realizzare tracciati ferroviari a norme, mantenendo sempre la lunghezza modulare di 155 mm.

40 3842

Tratto doppio parallelo incrociato.

40 3843

Tratto parallelo deviato a destra.

40 3844

Tratto parallelo deviato a sinistra.

Ed è appunto con questi nuovi sistemi modulari che la LIMA è riuscita a ridurre gli spazi necessari per realizzare un corretto tracciato ferroviario.

DETTAGLI TECNICI

Gli elementi modulari hanno una **lunghezza di 155 mm, l'interbentario di 52 mm.**

Questa lunghezza di deviazione permette, mediante l'utilizzazione degli elementi modulari del sistema, la costruzione di tracciati e la combinazione di scambi in uno spazio estremamente ridotto.

Il cuore degli scambi è in metallo. Le lame dei deviatori, fresate, si appoggiano perfettamente alle rotaie e garantiscono un contatto ottimale e permanente.

The introduction of 3 new modular elements, fundamental for railway layouts coupled with switch and crossing elements, gives the possibility to build a railway layout on rules, always keeping the 155 mm modular length.

40 3842

Crossed parallel double scissors.

40 3843

Right hand crossover.

40 3844

Left hand crossover.

With these new modular elements, LIMA managed to reduce space necessary to build a scale railway layout.

TECHNICAL SPECIFICATIONS

The modular elements have a length of 155 mm, scale six-foot way of 52 mm.

This deviation length allows to build, through the utilization of the system modular elements, layouts and switch combinations in an extremely reduced space.

The frog is in metal.

The point blades, milled, adhere perfectly to the tracks and produce a permanent optimum contact.

NEW⁸⁸



40 3842

NEW⁸⁸



40 3843

NEW⁸⁸



40 3844



PROGRAMMA BINARI TRACK PROGRAMME

NICKEL SILVER

NEW 88

BINARI DIRITTI - STRAIGHT TRACKS



Binario 310 mm.
straight track.

NEW 88



40 3821
Binario diritto 155 mm.
155 mm straight track.

BINARI CURVI - CURVED TRACKS

NEW 88



40 3810 Binario curvo 30°, raggio 652 mm.
Curved track, 652 mm, 30° radius.

R2 = 652 mm

NEW 88

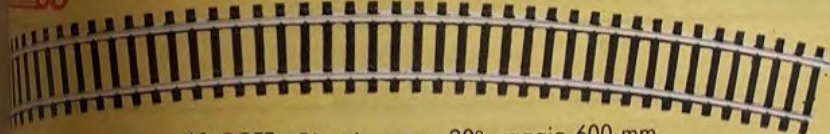

40 3811 Binario curvo 30°, raggio 600 mm.
Curved track, 600 mm, 30° radius.

R1 = 600 mm

R-704
R2-652
R1-600
52 52

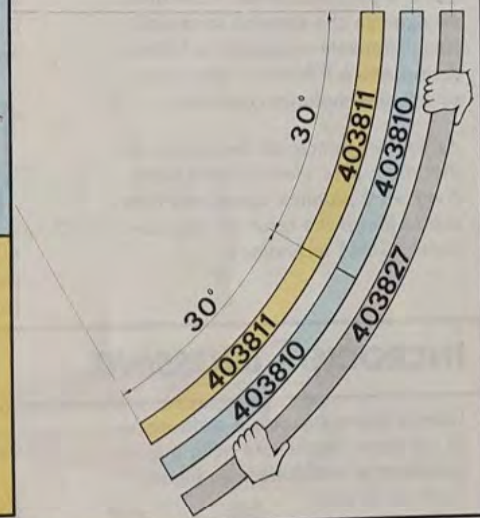

NEW 88

BLOCCAFLEX LIMA - THE LIMA FLEX



407
Inseparabile. Lunghezza 900 Flexible track. Length 900 mm.

BLOCCAFLEX

È un accessorio appositamente studiato dalla LIMA, mai esistito fino ad oggi, che permette, nell'utilizzo dei binari flessibili, di posizionarli correttamente e nella forma desiderata, senza ricorrere a tutti i dispositivi e particolari accorgimenti necessari per evitare che la traversina si sfilino dalla sede, creando grossi problemi di manutenzione e nella stessa posa del binario. Il Bloccaflex è inoltre munito di un sistema di bloccaggio che permette di posizionare i binari in modo stabile, mantenendo sempre lo stesso intervallo tra di loro.

FLEX-BLOCK

The "flex-block" is a particular accessory, expressly designed by LIMA (produced by no other manufacturer before), which allows, when using flexible track, the correct scaled position and shape.

That happens without having to resort to all those devices which are necessary actually to avoid tracks or sleepers being drawn out from their seat, creating in this way problems for the correct setting.

The "flex-block", in addition, is equipped with a rod which allows the flexible track to be laid in position with a constant scale six-foot way.

NEW 88

60 0068
Bloccaflex - Flex-block.



I DEVIATORI - POINTS BLADE MODULE

NEW⁸⁸

DEVIATORI MANUALI MANUAL POINTS

Nella nuova geometria modulare ogni deviatore è composto di un binario diritto della lunghezza di 155 mm ed una deviatrice di raggio di curvatura di 941 mm, 9° 30'.

In the new modular geometry every point is composed of a frog module length 155 mm and a blade module of 155 mm length with radius of 941 mm at 9° 30'.



40 3830
Deviatore destro 9° 30'. Lunghezza 155 mm.
Right 9° 30' point blade module. Length 155 mm.



40 3831
Deviatore sinistro 9° 30'. Lunghezza 155 mm.
Left 9° 30' point blade module. Length 155 mm.

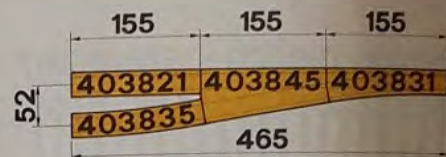

DEVIATORI ELETTRICITÀ ELECTROMAGNETIC POINTS

Come si può notare, tutti i deviatori, sia manuali che elettrici, sono stati completamente ridisegnati e la loro costruzione è il frutto di una avanzatissima tecnologia costruttiva.

As you will notice, all the points, either manual or electric, have been completely planned again and their production is the result of very advanced LIMA technology.



40 3830E
Deviatore elettromagnetico destro 9° 30'. Lunghezza 155 mm.
Right electromagnetic 9° 30' point blade module. Length 155 mm.



40 3831E
Deviatore elettromagnetico sinistro 9° 30'. Lunghezza 155 mm.
Left electromagnetic 9° 30' point blade module. Length 155 mm.

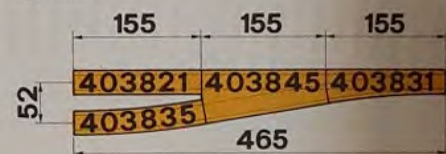
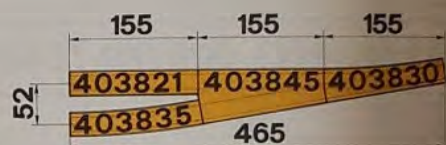

INCROCIO - CROSSING

Questo nuovo incrocio è stato ideato per poter mantenere nella nuova geometria modulare un interbinario di 52 mm.

This new crossing has been conceived in order to keep a 52 mm scale six-foot way in the new LIMA modular geometry.

NEW⁸⁸



40 3841
Incrocio 9° 30'. Lunghezza 155 mm. 9° 30' crossing. Length 155 mm.

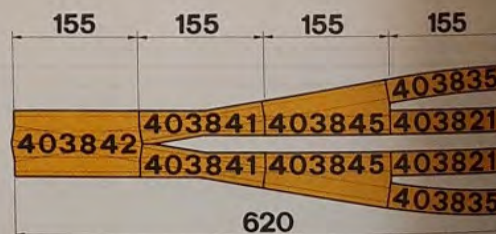

CUORE - FROG MODULE

È l'elemento base di tutto il Sistema Modulare di binari LIMA.

Accoppiato indifferentemente all'elemento deviatore destro o sinistro, realizza lo scambio sia destro che sinistro.

Accoppiato all'incrocio o al doppio scambio inglese, realizza l'intersezione tra due vie di corsa.

This is the basic element for all the LIMA track modular system. Coupled either to the right or left point blade module, it carries out either the right or the left switch.

Coupled to the crossing or double crossing, it carries out the intersection between two running tracks.

NEW⁸⁸



40 3845
Cuore a 9° 30' per tutti gli scambi ed incroci. Lunghezza 155 mm.
9° 30' frog section for all points and crossings. Length 155 mm.

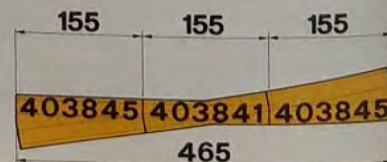
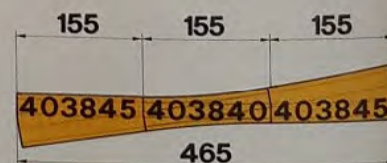

NEW⁸⁸

40 **3842**

Tratto doppio parallelo incrociato 9° 30'. Lunghezza 155 mm.
9° 30' *crossed parallel double section. Length 155 mm.*

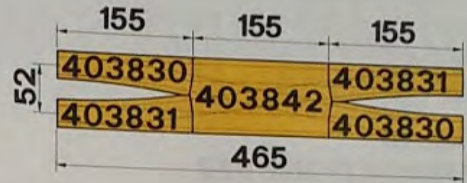
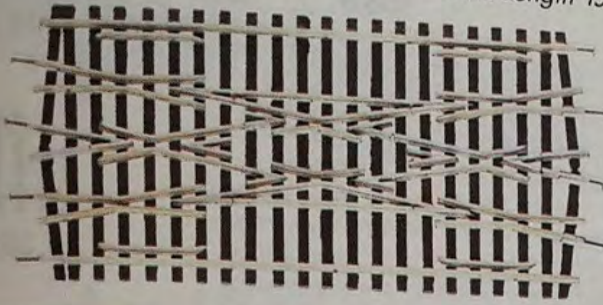

INGLESE - DOUBLE SLIP

NEW⁸⁸



40 **3840E**

Doppio scambio inglese elettromagnetico 9° 30'. Lunghezza 155 mm.
9° 30' *electromagnetic double slip, length 155 mm.*

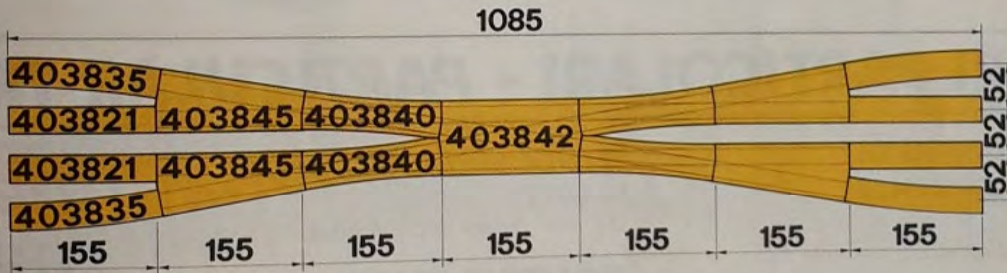

**ELETTROMAGNETICHE MOBILI
MOTOR POINTS**

NEW⁸⁸



60 **0881**

Scatola elettromagnetica mobile sinistra per deviatori e scambi inglesi.
Point motor to electrically control left points.

NEW⁸⁸



60 **0880**

Scatola elettromagnetica mobile destra per deviatori e scambi inglesi.

BINARIO TRASVERSALE

40 3824

Binario diritto mm 158,5 trasversale.

Questo tratto di binario è necessario per compensare gli elementi di binario diritti quando, anziché impiegare gli elementi di binario a tratti paralleli devianti, si usino due cuori, ottenendo così un interbinario di 78 mm necessario per collocare pensiline, marciapiedi ed altri impianti fissi di stazione.

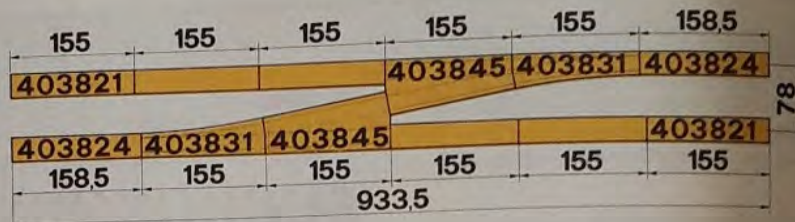

This track section is necessary to compensate the straight track elements when, instead of using the track element at diverted parallel sections, two frogs are utilized. In this way you can get a 78 mm scale nine-foot way necessary to place platforms and other station fixed equipment.



40 3824

BINARI DI COMPENSAZIONE PER SCAMBI

40 3835

Binario di compensazione per scambi.

Pur essendo la deviata dello scambio con il cuore composta da un binario curvo di R = 941, 9° 30' ed un binario diritto di mm 155, la compensazione è unica, costituita da un binario curvo 9° 40' R = 941.

Con questo si è evitato di utilizzare due binari di compensazione destro o sinistro per scambi ed incroci, a tutto vantaggio di un maggior realismo e minori problemi di realizzazione dei tracciati (molto semplificati).

COMPENSATING TRACK FOR POINTS

40 3835

Compensating track for points.

Even if the point blade of the switch with the frog is composed by a curved track of radius 941, 9° 30' and a straight track of 155 mm, the compensation is only one and consists of a 9° 40' curved track, radius 941.

In this way it can be avoided to use two left or right compensating tracks for switches and crossings and the most important advantages of that is more realism and less problems of layout building (much simplified).



40 3835

COMPENSATING TRACK

40 3824 158,5 mm straight compensating track.

BINARI PARTICOLARI - PARTICULAR TRACKS

BINARIO DIRITTO DI PRESA DI CORRENTE

40 3822

Binario diritto di presa di corrente 155 mm.

BINARIO DI INTERRUZIONE DEL CONTATTO CORRENTE

40 3823

Binario con interruzione del contatto di corrente mm 155.

È un binario sezionato solo su una delle due rotaie, usato principalmente per binari tronchi (interruzione di un polo passante da un interruttore o pedale di contatto), per i sezionamenti sotto tensione e per binari d'arresto in prossimità di segnali.

BINARIO TERMINALE DIRITTO

40 3825

Binario terminale diritto mm 155.

BINARIO ALLUNGABILE

40 3826

Binario allungabile.

È un binario speciale allungabile da 111 mm a 165,5 mm, necessario se si vuole aumentare l'interbinario soprattutto nei piazzali di stazione per eventuali esigenze di spazio nella posizionatura di opere fisse pensiline, marciapiedi, ecc.

FEEDER STRAIGHT TRACK

40 3822

155 mm feeder straight track.

ISOLATING TRACK

40 3823

155 mm track with current contact interruption.

It is a track which is sectionalized only on one of the two rails, used mainly for sidings (interruption of one pole passing through a switch or contact relay), under tension sectionings, stop tracks for signals.

STRAIGHT TERMINAL TRACK

40 3825

155 mm straight terminal track.

EXTENDABLE TRACK

40 3826

Extendable track.

This is a special track extendable from 111 mm to 165,5 mm in length, necessary if you want to increase the six-foot way for platforms in station area.

NEW⁸⁸



40 3822

NEW⁸⁸



40 3823

NEW⁸⁸

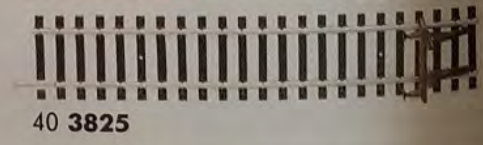

40 3825

NEW⁸⁸



40 3826

in curva LIMA sono realizzati
 in un arco di 30° (R1 = 600
 mm) e un binario
 40 3811, e un binario
 sempre a 30° pari ad un
 ottenendo così, con
 coppia di scambi, un interbi-
 corrispondente alla
metria modulare LIMA,
 all'ausilio di altri ele-
 L'angolo al centro otte-

ed points are carried out
 track (R1 = 600 mm as
 and a 30° track (R2 =
 track 40 3810).
 with only one
 a 52 mm scale six-foot
 correspondent to the new
 geometry, without having
 other track elements.

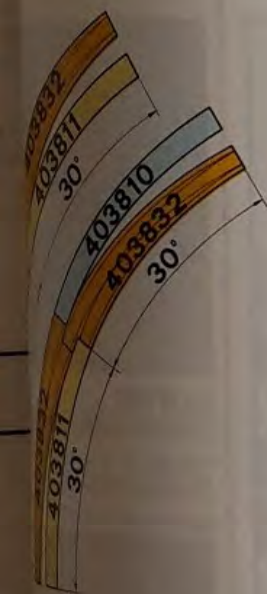

**PARALLELO
 A DESTRA**
 accoppiato a due de-
 il passaggio da un
 ottenendo un'intervio di
 nuovo **Sistema**
 LIMA e alla norma NEM

**PARALLELO
 A SINISTRA**

caratteristiche del trat-
 precedente ma ac-
 deviatori sinistri, per-
 inverso dal prece-

sopra descritti rea-
 di un convoglio da
 contenendo la lun-
 cambi in 465 mm pari a
 nuovo **Sistema Modu-**
 che l'angolo di
 30° che permet-
 dagli scambi

SCAMBI IN CURVA MANUALI MANUAL CURVED POINTS

40 3832
 Coppia di scambi in curva raggio 600 e 652 mm, 60°.
 Pair of curved points, 600 and 652 mm, radius 60°.

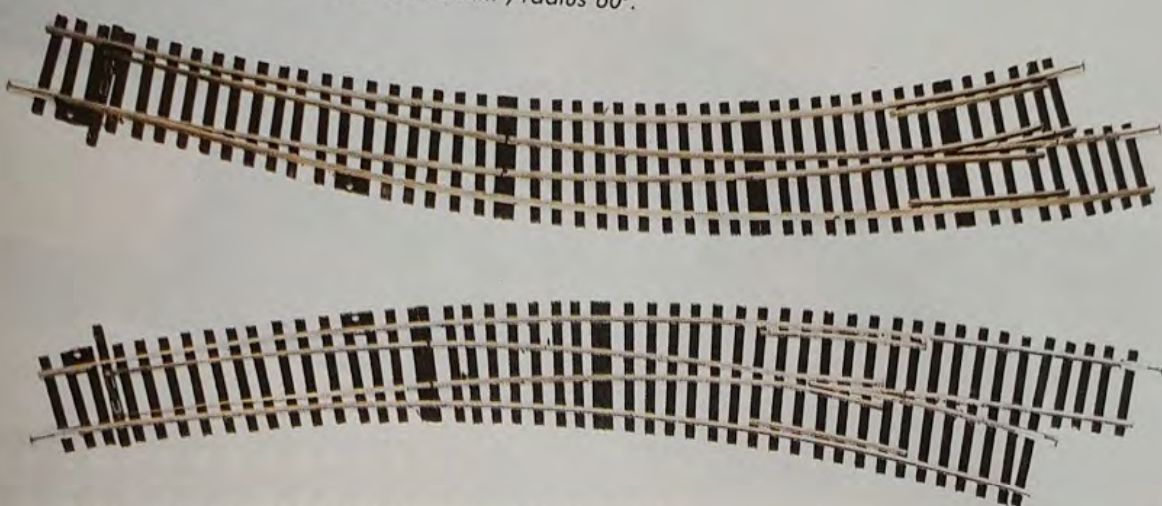

SCAMBI IN CURVA ELETTROMAGNETICI ELECTROMAGNETIC CURVED POINTS

40 3832E
 Coppia di scambi elettromagnetici in curva raggio 600 e 652 mm, 60°.
 Pair of electromagnetic curved points 600 and 652 mm, radius 60°.

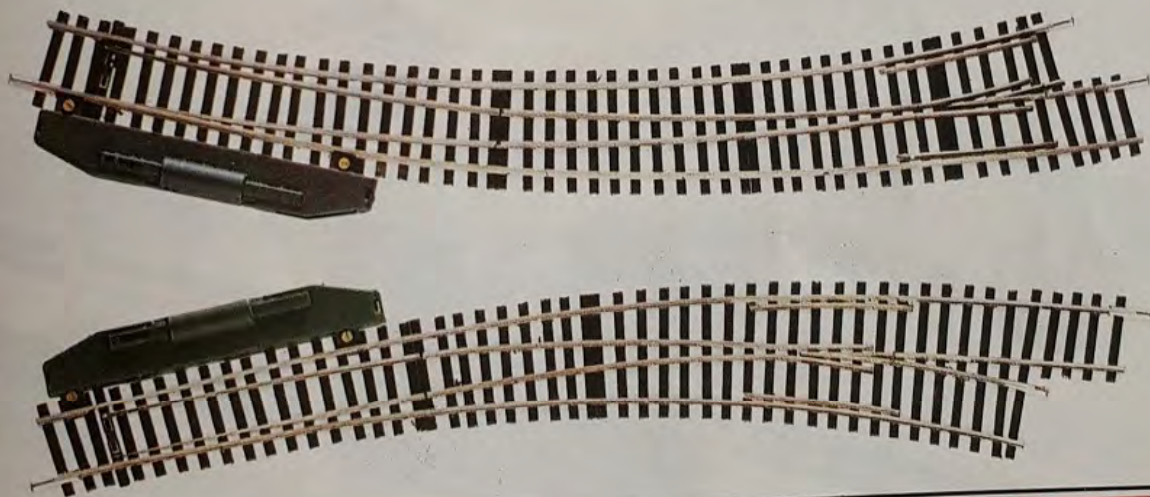

NEW₈₉

RIGHT HAND CROSSOVER

40 3843
 This is the element which, coupled with two right point blade modules, carries out the passage from one track to another.

In this way you can get a 52 mm scale six-foot way in accordance to the new LIMA modular system and NEM 112-1 rules.

LEFT HAND CROSSOVER

40 3844
 With the same specifications of the previous turned parallel section but coupled to two left point blades. It allows the inverse passage in comparison with the previous one.

Both the above mentioned items carry out the passage of a train from one track to another, keeping the length of the switches to 465 mm, equal to 3 modules of the new LIMA modular system, because the connection angle is only 9° 30'.

This allows the point to be used with absolute safety.

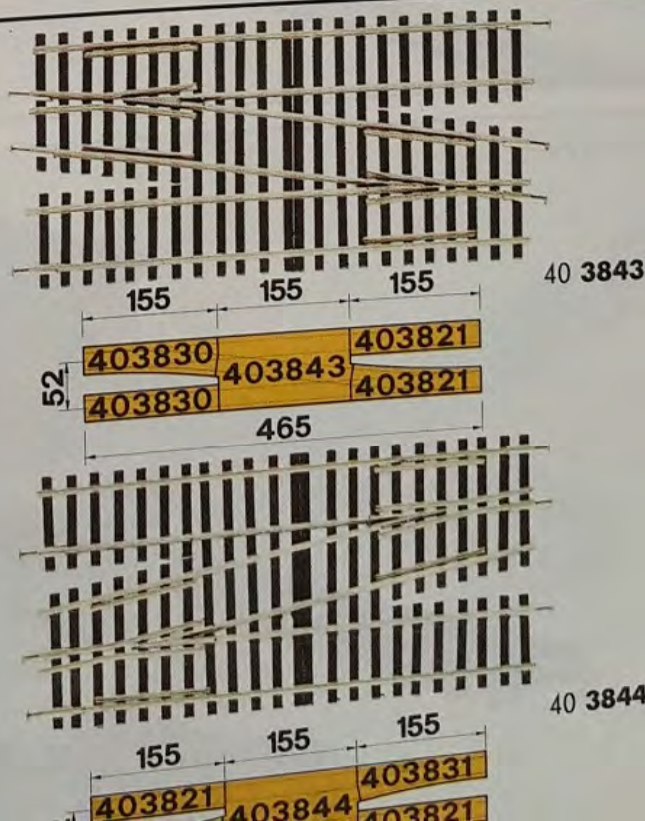

60 0940

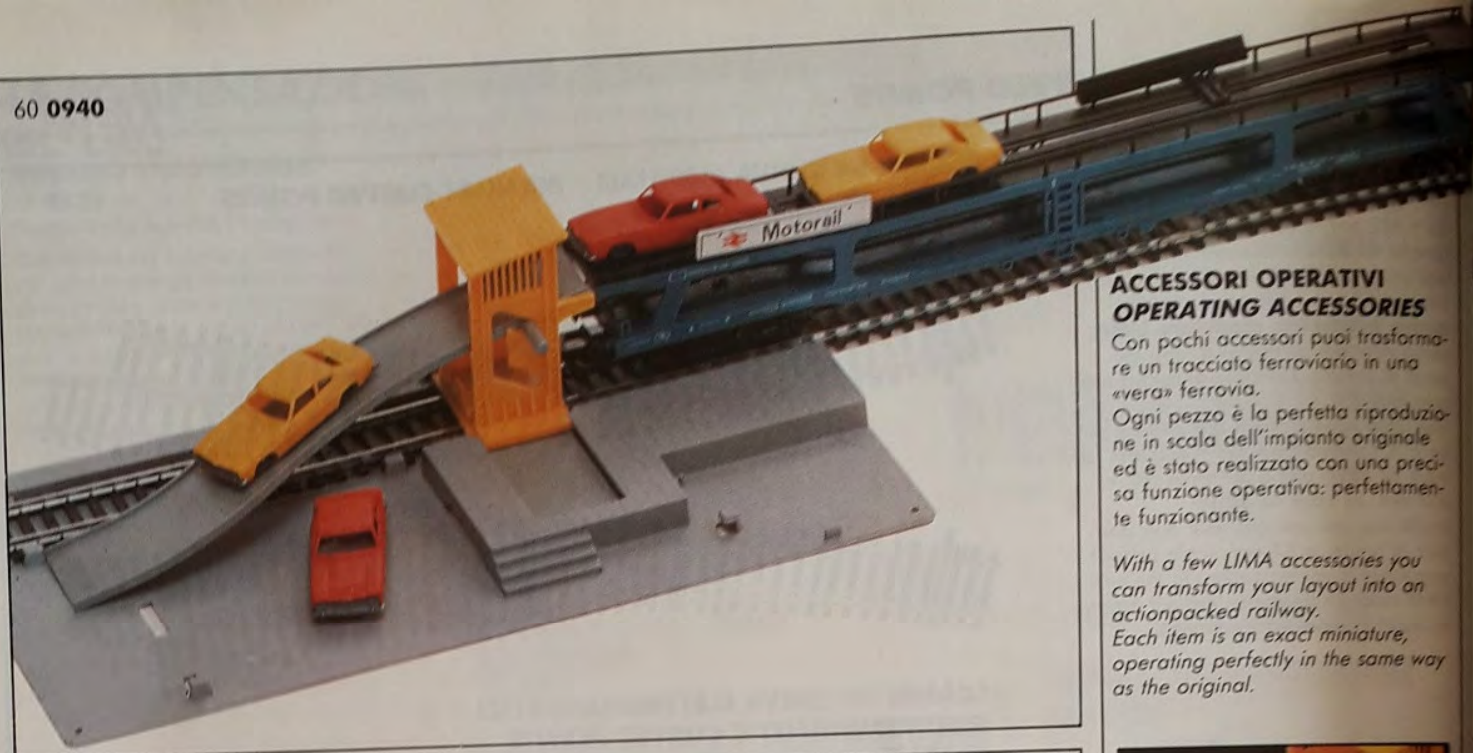

**ACCESSORI OPERATIVI
OPERATING ACCESSORIES**

Con pochi accessori puoi trasformare un tracciato ferroviario in una «vera» ferrovia.

Ogni pezzo è la perfetta riproduzione in scala dell'impianto originale ed è stato realizzato con una precisa funzione operativa: perfettamente funzionante.

With a few LIMA accessories you can transform your layout into an actionpacked railway.

Each item is an exact miniature, operating perfectly in the same way as the original.

60 0960



60 0940

Carro trasporto «Mercedes» e terminal per lo scarico automatico.
Transporter wagon with terminal for automatic unloading of cars.



60 0970

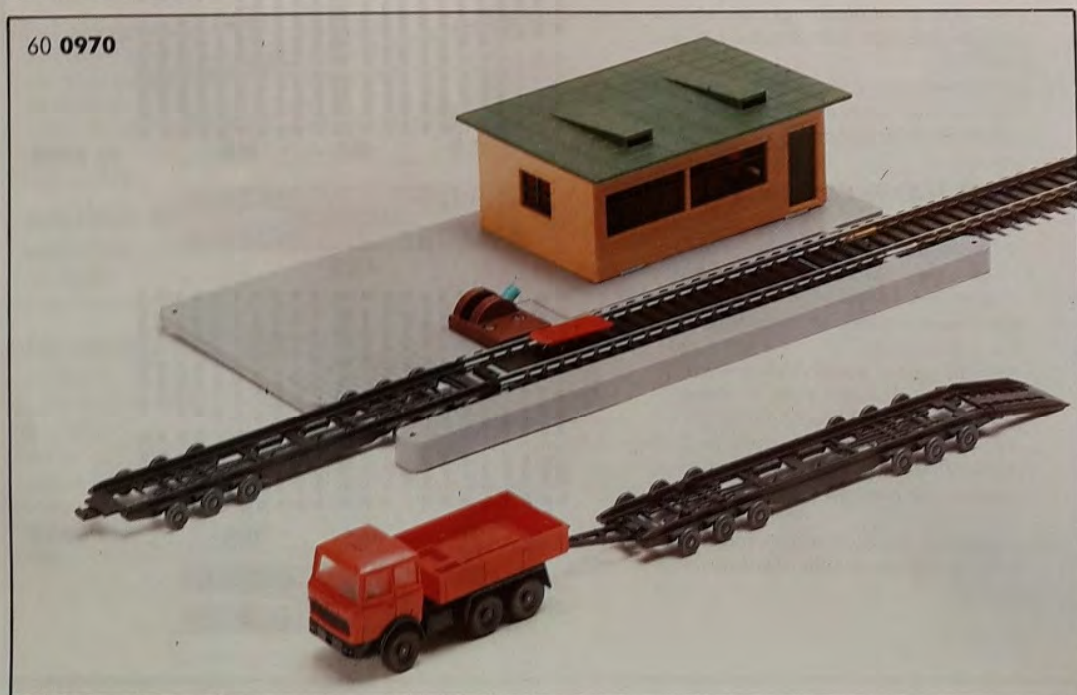

60 0960

Terminal per containers, con 2 containers, carro pianale e camion.
Freightliner terminal with rail transporter and two container lorries.



60 0970

Terminal di scarico e camion con carrello per trasporto stradale di vagoni.
Rolling stock road transporter.

containers.
loading crane.



60 0052

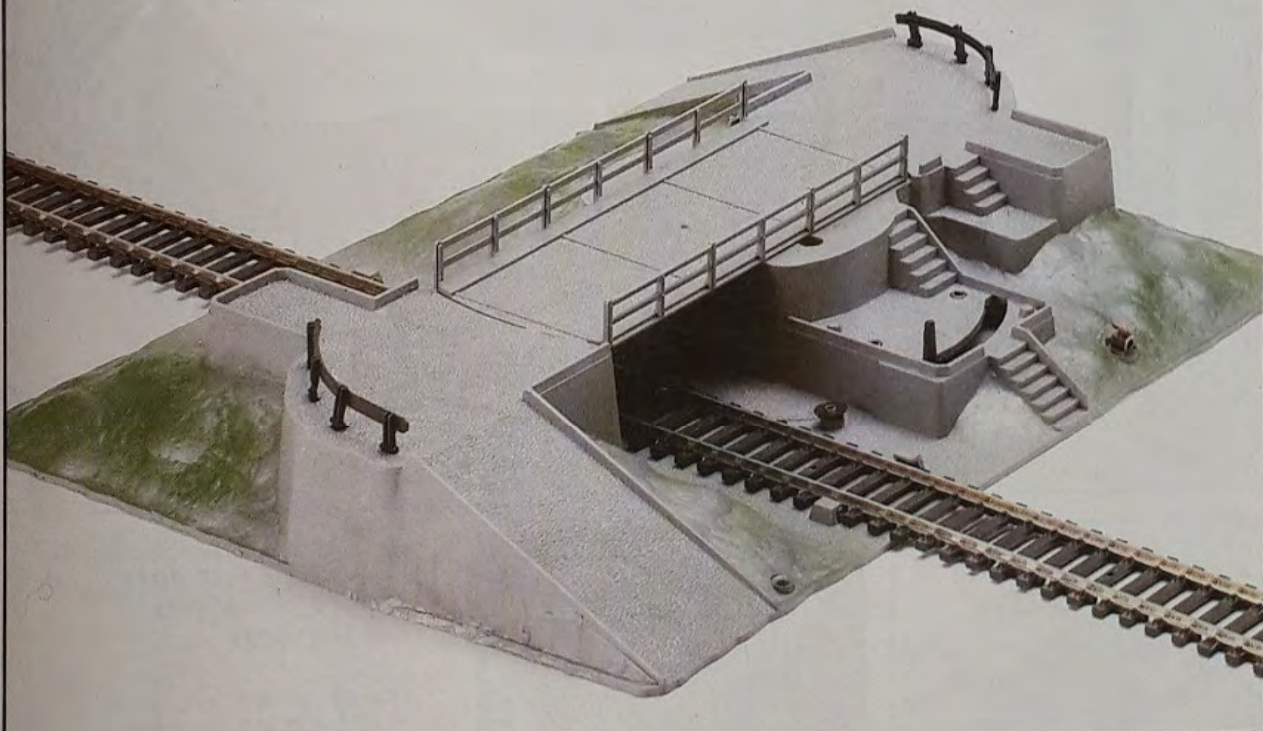

60 0021



con arresto automati-
camente la bridge with auto-
stop.

nello a funzionamento
automatico crossing.

60 0951

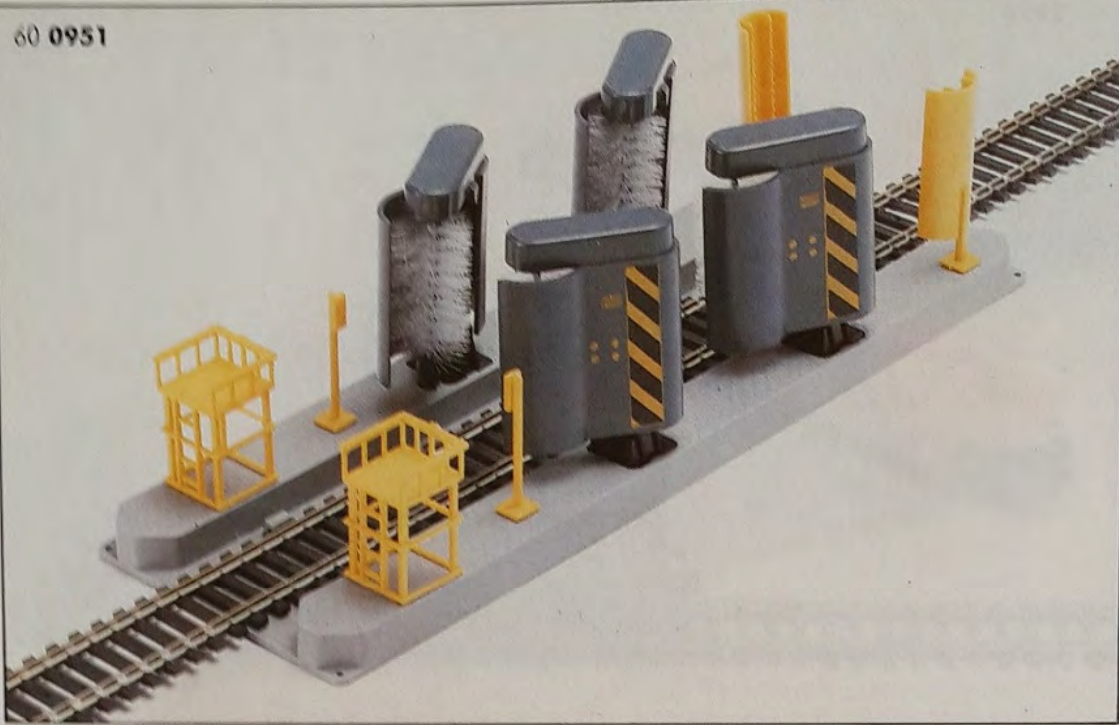

60 0951
 Stazione per lavaggio vagoni.
Automatic coach wash.

**ACCESSORI SCENOGRAFICI
 SCENIC ACCESSORIES**



60 0031

60 0031
 Pensilina per stazione.
Station roof.



Stazione di corsa composta da
 1x60 0033 e 1x60 0031
*Station with 1x60 0033
 and 1x60 0031*

Stazione di testa composta da
 1x60 0033 e 3x60 0031
*Terminal station with 1x60 0033
 and 3x60 0031*

60 0033
 Stazione centrale.
Main station.

60 0033



road and sign.

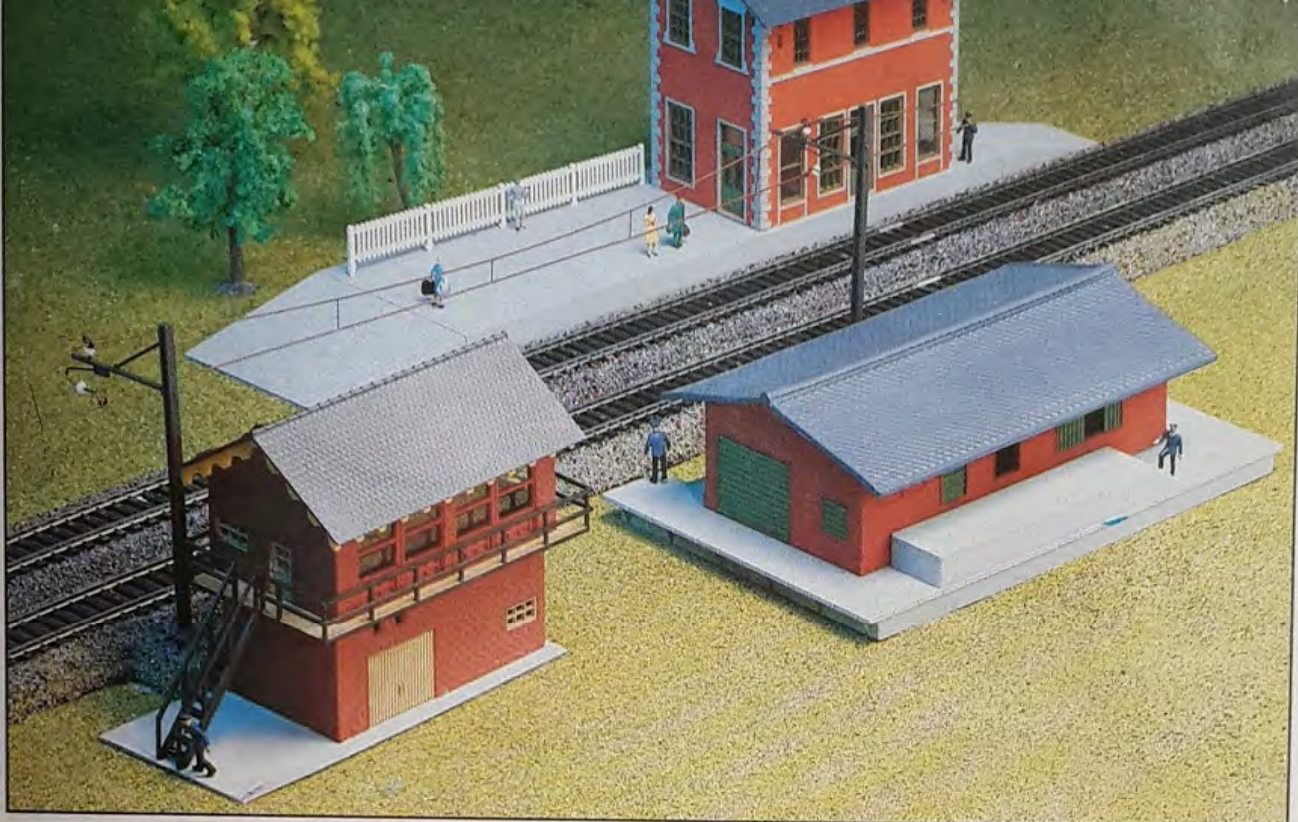

...to da: terminal au-
...rose, un cottage,
...e un camion.
...g of: vehicle tran-
...o houses, a cotta-
...one lorry.





60 0070
 Deposito composto da: ricovero locomotive e posto di blocco.
Engine shed consisting of: engine shed and signal box.



metrico. L'ottimale, è quella di
 la seconda pianta pla-
 naria la prima, a circa
 altezza, collegando i
 binario con salite e

non dimenticare che
 come del resto

non può superare pen-
 elevate. Se la salita è
 le ruote slittano e il
 riesce ad avanzare.
 semplificazione si può
 pendio previsto è del
 di accesso non dovrà
 più di 3 cm. in altezza
 lineare di binario.
 gere quindi un'altezza
 correrà una rampa di-
 metri di binario. Utiliz-
 zando pioli corti, quindi con
 da trainare, è possibile
 o salite ripide del 4,5%
 di ottenere l'altezza
 su soli 2 metri di binario

biggest problems to be
 railway modellers is
 space. One answer is to
 other layout some 8-10
 the first - but it is impor-
 tant to remember that a locomotive
 can't climb certain gradients. If
 the gradient is too steep the driving
 wheels slip and the locomotive
 is unable to reach the top.
 As a rule, if the gradient is
 too steep the ramp must not exceed 3
 percent per meter. Thus, in this
 case the ramp to give a height
 of 9 cm the gradient must be spread
 over 2 meters of track. Where
 a steeper incline is used a
 locomotive up to 4,5% - giving a
 height of 9 cm is desi-

lo-
 e



60 0912



60 0913

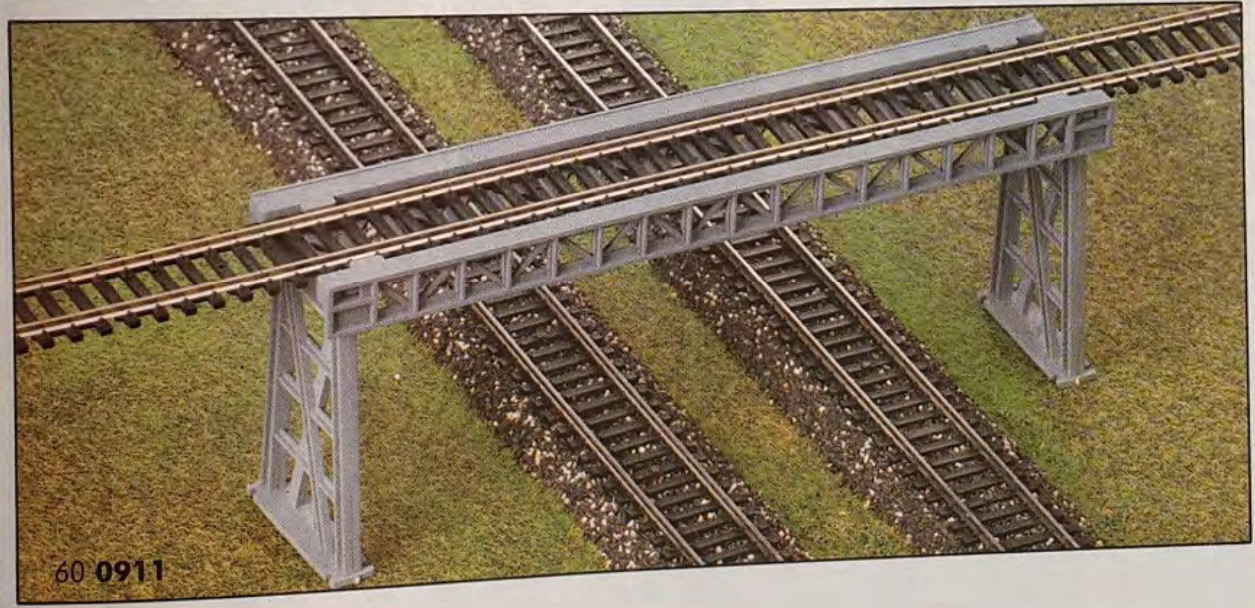

60 0911

elevato su tratto curvo e
 elevato su tratto rettili-
 ggio in a curved stretch
 bridge in a straight

colto a «8» sopraeleva-
 a /a





60 0823

60 0822

60 0823
 Due Fiat 131.
 Fiat 131 (two car pack).
 60 0822
 Due Ford Capri.
 Ford Capri (two car pack).

60 0832
 Containers «RACE»/
 «ACL»/«Safmarine»/«TNT».
 60 0830
 Containers «HAPAG»-
 «LLOYD»/«SEALAND»/
 «D.B.»/«DANZAS»



60 0830



60 0832

60 0803
 Camion aperto.
 Open lorry.
 60 0804
 Autocisterna Shell.
 Shell petrol tanker.
 60 0801
 Camion container «ACL».
 ACL container lorry.
 60 0807
 Camion container «Dunlop».
 Dunlop container lorry.
 60 0805
 Camion container «Sea Train».
 Sea-Train container lorry.



60 0801



60 0805



60 0807



60 0803



60 0804

...a disposizione dei
...che sono disposti
...dei binari. Il lin-
...a rosse e verdi dei
...tatti la marcia dei
...l'andatura,
...l'arresto
...quando due di es-
...stessa linea o so-
...di un'intersezione.
...anche in questo
...serie di segnali con
...anza, che proteggo-
...dei convogli e as-
...priorità del traffico

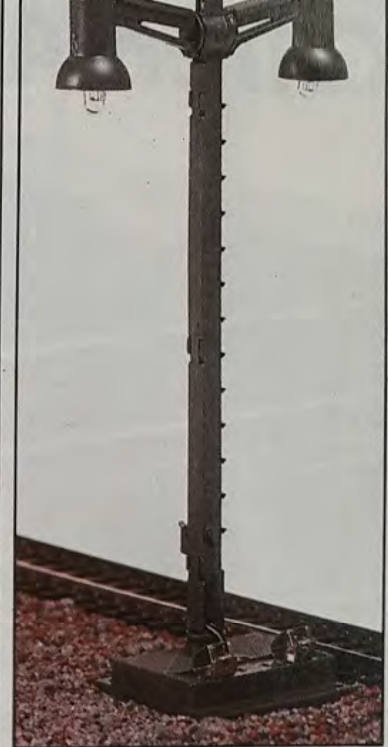

60 0023

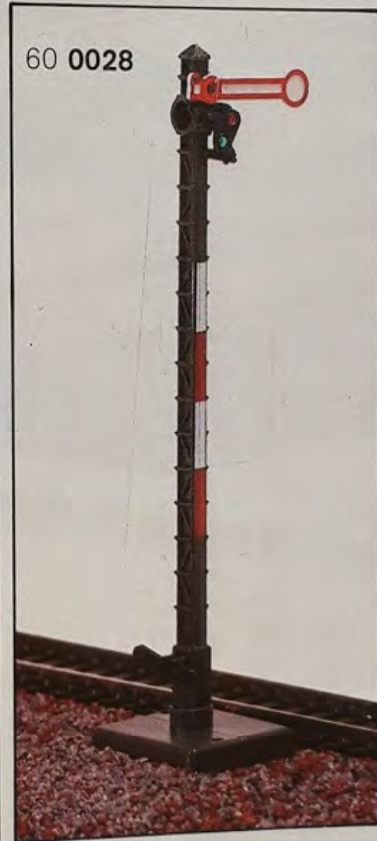

60 0028



60 0026



60 0029

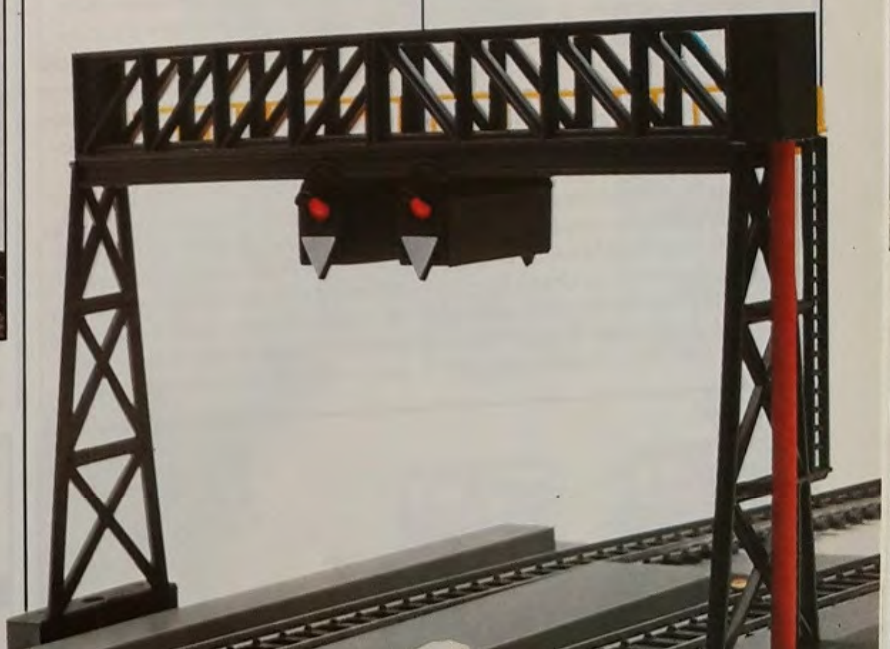

60 0025

appearance of a model
conditioned by either
the location of si-
line. The language
and green variable
the run of trains, it
down, automatically
and resumes speed when
are running on the sa-
approaching an in-
offers a wide choi-
operated signals,
and protect the rail-
...onna, a luce rossa e
...ardo.
...light signal with con-
...onna a 4 luci con
...with control switch
...riera a due posizioni.
...position signal.
...with control switch.
...a portale con
...automatico.
...gantry with level
...train stops when the
...lowering the barriers lo-
...when the train is
...a disco mobile
...with control switch.
...ONE
...baraccia.
...arm.
...baraccia.
...arm.

CATENARIA CATENARY

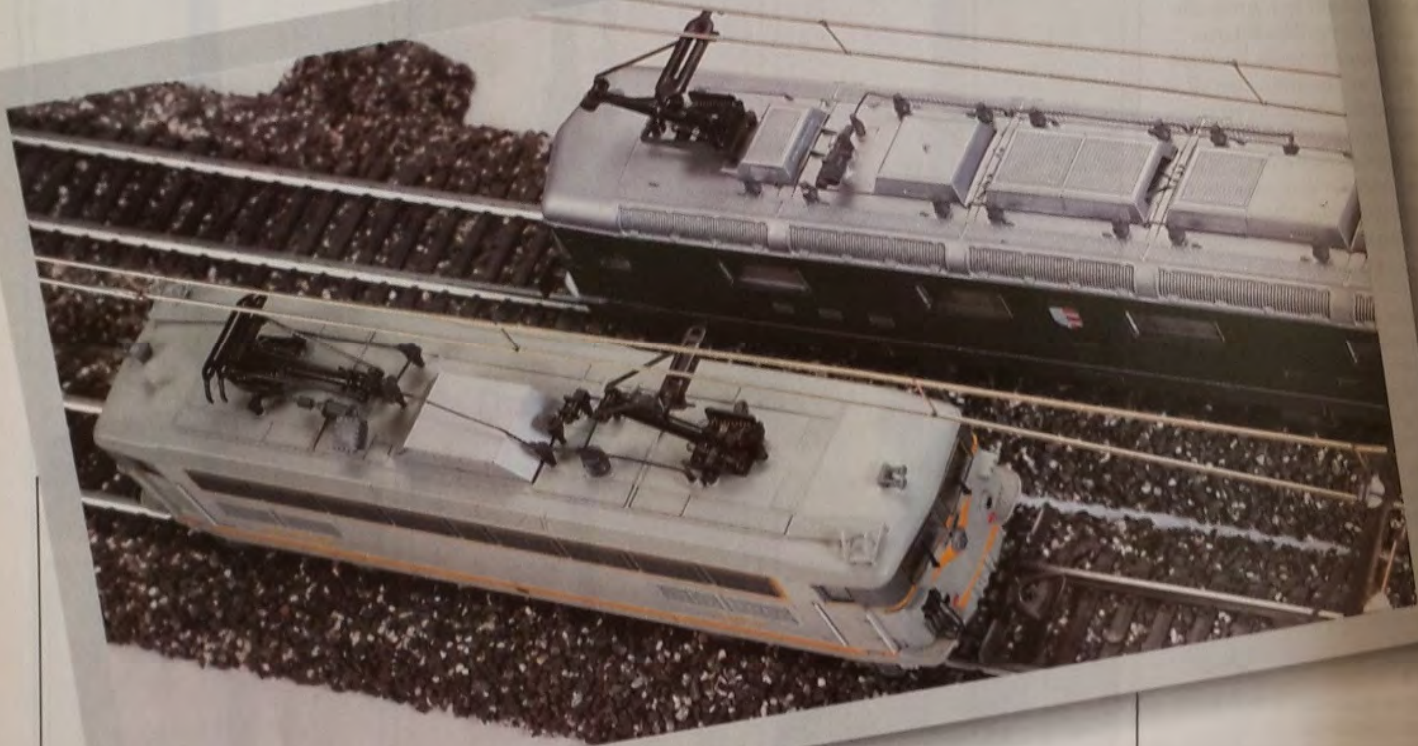

L'ELETTRIFICAZIONE A CATENARIA

Come avviene nella realtà, le locomotive elettriche in miniatura possono ricevere la corrente di alimentazione dal filo aereo a catenaria che si sviluppa, sostenuto da appositi pali, lungo l'intero circuito dei binari; un polo della corrente passa dal filo al motore della locomotiva attraverso il pantografo — che funge da contatto strisciante — mentre l'altro polo percorre una delle due rotaie e giunge al motore attraverso le ruote. Si consegue così non solo un effetto di estrema fedeltà alla ferrovia reale ma anche il vantaggio di poter far circolare sulla stessa linea (e indipen-

dentemente una dall'altra) due locomotive, una che viene alimentata solo dal binario, l'altra che riceve corrente da una delle due rotaie e dalla linea aerea. Bisognerà ovviamente che le ruote di presa corrente delle due locomotive siano tutte disposte sulla rotaia alimentata in comune dai due trasformatori; in tal caso il senso di marcia e la velocità delle due motrici potranno essere regolati in modo indipendente.

Nelle illustrazioni figurano alcuni esempi di linea aerea a catenaria su trati rettilinei, a doppio binario e in prossimità di scambi. Si noti come i pali siano disposti sempre dallo stesso lato del binario e come essi siano muniti di supporti alternati lunghi e corti, affinché — come nella realtà —

la linea aerea segua un percorso a zig-zag. Ciò consente un migliore contatto fra il filo aereo e il pantografo ed evita che quest'ultimo si usuri in un solo punto. Il sistema a catenarie LIMA, al pari del sistema di binari LIMA, è concepito in modo da assicurare la massima modularità e compatibilità al binario.

Sono disponibili 4 diversi tipi di pali di sostegno per catenaria:

- 60 2950 - a mensola corta
- 60 2951 - a mensola lunga
- 60 2952 - per attacco corrente
- 60 2954 - di testa.

Esiste inoltre una mensola a prolunga (art. 60 2953) da impiegarsi in corrispondenza degli scambi.

Gli elementi di catenaria LIMA, che vengono posti fra un palo e l'altro, sono di diverse lunghezze e vengono variamente impiegati a seconda del-

le caratteristiche del tracciato.

60 2960 - elemento lungo mm 333.

60 2961 - elemento lungo mm 222.

60 2962 - elemento lungo mm 166,5.

CATENARY ELECTRIFICATION AND INSTALLATION

As with real electric locomotives, electric current is collected from overhead wires fed from catenary supported on a series of insulated posts positioned along side the track, the power passes from the overhead wires to the motor of the locomotive via the pantograph.

The other contact is from one of the two rails and completes the circuit to the motor through the locomotive wheels.

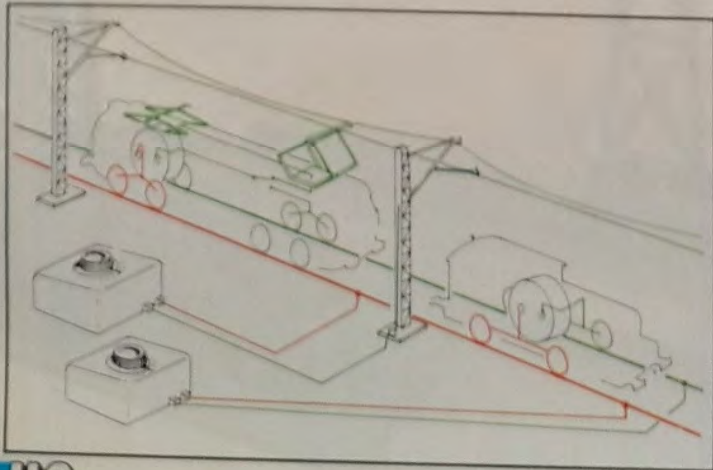

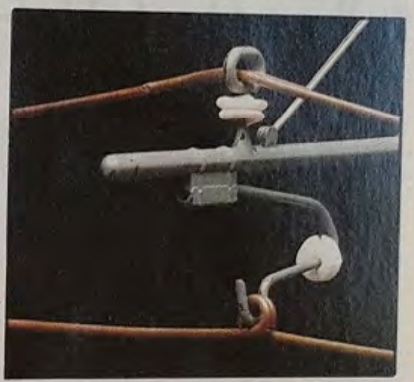
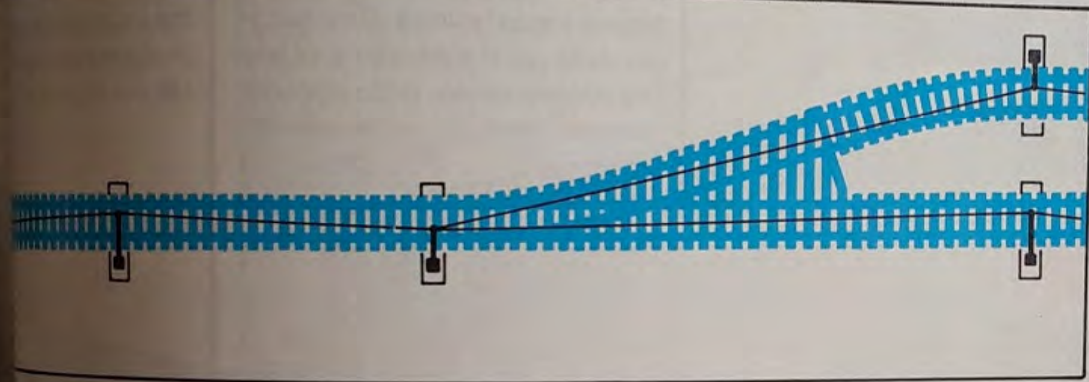
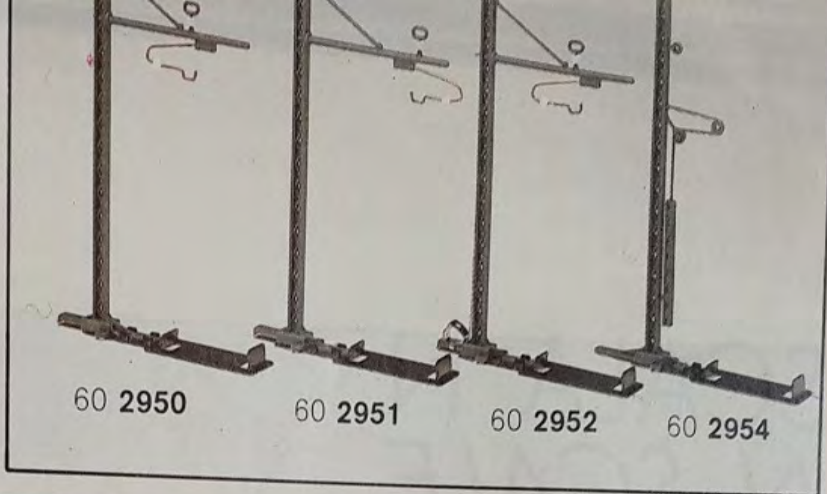
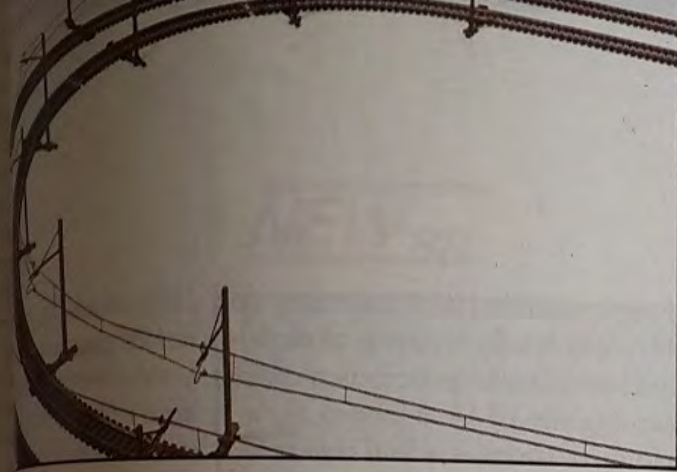

PER «ELETTRIFICARE» LA LOCOMOTIVA

Per predisporre le locomotive elettriche LIMA all'alimentazione mediante linea aerea è necessario avvalersi di una speciale confezione LIMA, nella quale sono compresi: un deviatore, il cavo elettrico necessario alla conversione, due pantografi, oltre ad un foglio dettagliato di istruzioni. Esistono tre diversi tipi di pantografi, variamente adattabili a seconda dei modelli di locomotiva. Rapida ed agevole è la trasformazione per «elettrificare» la locomotiva.

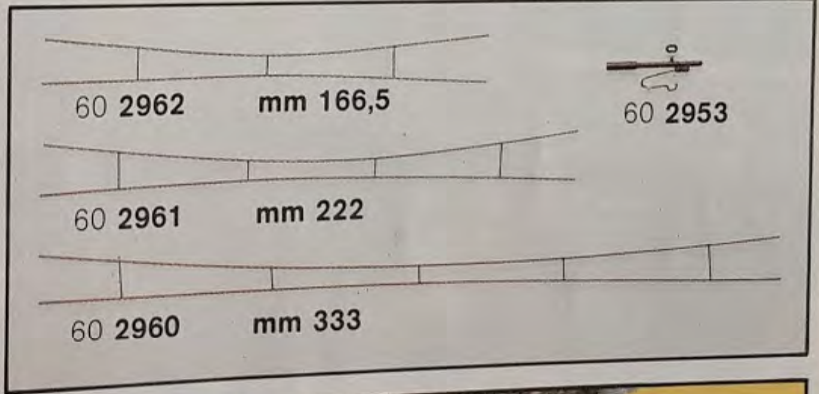

ELECTRIFICATION OF YOUR LOCOMOTIVE

If you wish to convert your LIMA electric locomotives to operate with overhead catenary in an easy way, you may purchase the special LIMA conversion kit which includes an adaptor, electric cable, pantograph and a detailed instruction sheet. There are three types of pantograph which are adaptable for different locomotives.



ing modern railway
is an additional ad-
ing able to have two
ing on the same line
operated, one collec-
from a rail whilst the
collect its current from
ires.
ed wheels of the two
t be on a common
transformers (see
ection and the speed
otives may be con-
sidently.
ary system is fully
the LIMA track sy-
a variable length
(60 2953) for posi-
e points. Examples
ad catenary wires on
es, are illustrated.
ous posts are al-
to the same side of
g long and short sup-
at, as with mo-
e, the overhead
g zig pattern, which
contact between the
and the pantograph,
ifferent types of
post:
ort support brac-
ing support brackets
ectrical terminals
catenary support.
y sections, which
e between catenary
ing lengths and
ording to the ne-

SCALA N N SCALE

I treni modello LIMA scartamento N (scala 1:160) esaltano al massimo l'alto livello tecnologico della produzione LIMA. Il lavoro di miniaturizzazione è infatti così spinto da non lasciare margine ad alcuna imperfezione di montaggio delle parti elettriche o al benché minimo errore nella riproduzione dal vero del materiale rotabile.

LIMA Model Trains in international 'N' gauge (scale 1:160) clearly show the high technical standard of LIMA at its best. The precise engineering of the locomotive is so sophisticated that both the locomotive's appearance and performance are truly remarkable.



NEW 88

...ico gruppo E424
...ava livrea per treni
...ocere, rosso fuoco e
...ezza fuori respingenti
...ways (FS) locomoti-
...in the new dust-grey,
...ange livery for com-
...Overall length mm 95.



22 0230

...ico Gruppo E444
...le FS; livrea grigio-
...ezza fuori respin-
...e Class E444 «Tar-
...s grey-blue-red live-
...mm 104.



32 0206

...ggeni UIC a comparti
...a colorazione rosso/
...ve italiane F.S. - L.
... UIC with 1st class
...ge A; in the red/
... Italian Railways F.S.



32 0852

...a UIC, nella colo-
...o delle Ferrovie
...5 mm.
... UIC, type D, in the
... Italian Railways



32 0349



FRANCIA-FRANCE

16 3901

TGV

Confezione «Micromodels» contenente un elettrotreno TGV delle SNCF nella livrea arancio-bianco-grigio; composto di quattro elementi:

22 0120L - motrice di testa, tipo M1. 22 0121 - rimorchiata mista, 1° classe R1. 22 0122 - rimorchiata mista, 2° classe R8. 22 0123 - motrice di coda, tipo M2, senza motore.

Il convoglio può essere inoltre integrato da uno o più elementi 22 0126, 22 0124 e 22 0125, acquistabili separatamente.

TGV

“Micromodels” set of TGV electric train of SNCF in its original orange-white-grey livery. Consisting of four units:

22 0120L - powered front-end car Class M1, 22 0121 - composite-luggage/first class coach, 22 0122 - restaurant/second class coach, 22 0123 - dummy rear-end car Class M2, without motor.

The train can also be enlarged by one or more additional units, separately available: 22 0126, 22 0124, 22 0125.



22 0126 - Rimorchiata intermedia di 1° classe R2-R3
First class TGV coach.



16 3906

«AUBRAC»

Confezione «Micromodels» contenente un convoglio passeggeri delle Ferrovie Francesi S.N.C.F., composto di quattro elementi:

22 0296 - locomotiva elettrica BB9468, livrea grigio chiaro - grigio scuro - giallo.

32 0324 - carrozza passeggeri «Corail» di 2° classe B¹¹tu, livrea grigio-arancio.

32 0325 - carrozza passeggeri «Corail» di 1° classe A¹⁰tu, livrea grigio-arancio.

32 0326 - carrozza mista «Corail» di 2° classe e bar B⁵rtux, livrea grigio-arancio.

«AUBRAC»

“Micromodels” composed with 4 elements.

22 0296 - electric locomotive of the S.N.C.F. in the set grey-brown-orange livery.

32 0324 - 2nd class Corail coach B¹¹ tu

32 0325 - 1st class Corail coach A¹⁰tu

32 0326 - combined 2nd class and Bar B⁵rtux Corail coach.



22 0228

22 0228

Locomotiva elettrica serie BB9400 (tipo BB9515) delle SNCF, livrea verde-bianco.

Electric locomotive Class BB9400 (type BB9515) of SNCF. Green-white livery.



rimorchiata intermedia di 2° classe e bar R4
bar TGV coach.

22 0124 - rimorchiata intermedia di 2° classe R5-R6-R7
Second class TGV coach.



22 0296



...merica serie BB9400
...nova livrea grigio chia-
...giallo.
...ive Class BB9400 of
...grey dark-grey live-

...LE DE L'ANNEE
1995

22 0203



Locomotiva diesel-elettrica serie BB67000 delle SNCF, livrea azzurro-bianco. Lunghezza fuori respingenti mm 105.
Diesel-electric locomotive Class BB67000 of SNCF in its blue-white livery. Overall length mm 105.

32 0883



NEW₈₈

32 0883
Carrozza passeggeri a comparti di 1° classe, tipo DEV A⁸, nella nuova colorazione verde-grigio, delle Ferrovie Francesi S.N.C.F. - L. 147 mm.
Passenger coach, with 1st class compartments, type A⁸, for International trains of the French Railways S.N.C.F. Green-grey livery - Length 147 mm.

32 0884



NEW₈₈

32 0884
Carrozza passeggeri a comparti di 2° classe, tipo B⁸, nella nuova colorazione verde/grigio delle Ferrovie Francesi S.N.C.F. - L. 147 mm.
Passenger coach with 2nd class compartments, type B⁸ for International trains of the French Railways S.N.C.F. New green-grey livery - Length 147 mm.

32 0878



NEW₈₈

32 0878
Carrozza passeggeri a comparti di 1° e 2° classe DEV nei colori d'origine delle S.N.C.F.
Passenger coach with 1st and 2nd class compartments, in original French State Railways (S.N.C.F.) livery.

32 0895



Coach DEV B° C°, bluegrey.

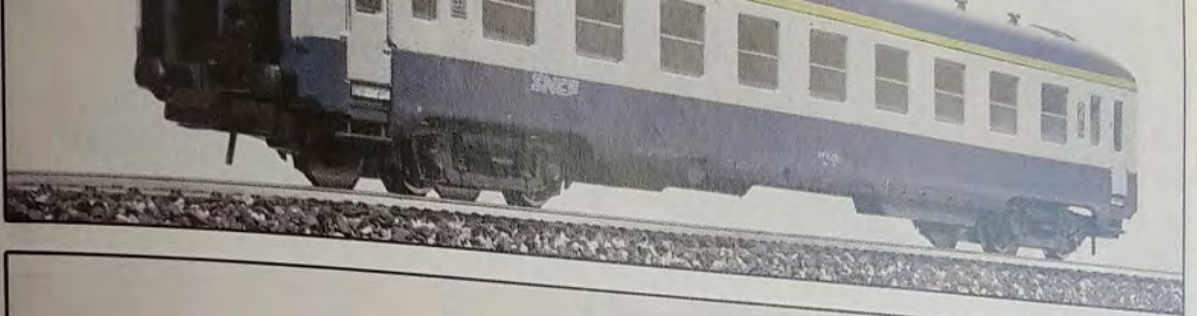

W88

...cette DEV B° C° nella livrea
...coach DEV B° C° in original

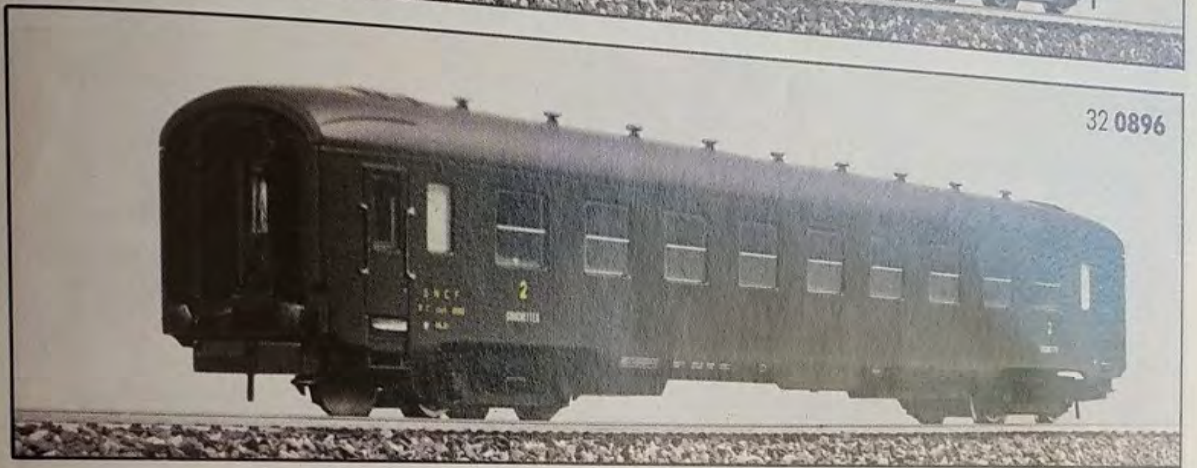

32 0896

W88

...bagagliaio, tipo Dd2, nella
...verde-grigio delle Ferro-
...S.N.C.F.
...coach, type Dd2, for inter-
...trains, of the S.N.C.F. Green-
...ry.



32 0322

...passenger compartments
...classe DEV A° nei colori
...SNCF.
...coach with 1st class com-
...DEV A° in French State
...S.N.C.F.) original livery.

...passenger compartments
...DEV tipo B° nei colori d'ori-
...SNCF.
...coach with 2nd class com-
...type DEV B°, in original
...Railways (SNCF) livery.

32 0894



32 0320



CORAIL

NEW₈₈

32 0320

Carrozza passeggeri Corail di 2° classe B¹¹tu nella livrea arancione «C1».

2nd class Corail coach B¹¹tu in the orange "C1" livery.

32 0321

**NEW₈₈**

32 0321

Carrozza passeggeri Corail di 2° classe nella livrea regionale «Midi-Pyrénées».

2nd Class Corail coach B¹¹tu in the regional "Midi-Pyrénées" livery.

32 0323

**NEW₈₈**

32 0323

Bagagliaio Corail, nella colorazione bianco-grigio-arancio, serie Dd2 delle Ferrovie Francesi (S.N.C.F.).

Luggage car Class Dd2 Corail of S.N.C.F. White-grey-orange livery.

32 0324



32 0324

Carrozza passeggeri «Corail» di 2° classe, nella colorazione grigio-arancio, tipo B¹¹tu, delle Ferrovie Francesi S.N.C.F.

Passenger coach, 2nd class, type B¹¹tu Corail, of the French Railways S.N.C.F. Grey-orange livery.

32 0325

Carrozza passeggeri «Corail» di 1° classe, nella colorazione grigio-arancio, tipo A¹⁰tu, delle Ferrovie Francesi S.N.C.F.

Passenger coach, 1st class, type A¹⁰tu Corail, of the French Railways S.N.C.F. Grey-orange livery.

32 0326

Carrozza passeggeri «Corail» di 2° classe e bar, nella colorazione grigio-arancio, tipo B⁵rtux, delle Ferrovie Francesi S.N.C.F.

Composite coach, 2nd class/bar, type B⁵rtux Corail, of the French Railways S.N.C.F. Grey-orange livery.



32 0325



NEW 88



32 0876

NEW 88

NEW 88



32 0875



32 0877



32 0326



SVIZZERA-SWITZERLAND

NEW₈₈

Nell'intento di rendere più attraente e rapido il traffico regionale, le CFF mettono in circolazione dei nuovi treni navetta. Essi si compongono di una automotrice RBDe4/4 (n. 2100-2103) e di un vagone pilota Bt (n. 900-903). La potenza sviluppata è di 1680 kW e la velocità raggiunge i 140 km/h. I convogli possono essere completati con delle vetture intermedie del tipo EW1/VU1.

I treni NPZ (chiamati Colibri) sono in servizio dal 1985 in Svizzera occidentale e nel nord-ovest.

Shuttle service is made more attractive by the Swiss SBB. Each of the four new NPZ "Colibri" prototypes RBDe 4/4 2100-2103 have different liveries and can be coupled with passenger coaches of the EW-1 unified types in green or matching colors.

Engine power is 1680 kW and maximum speed is 140 km/h. In service since 1985, they are seen in the West and Northwest areas of Switzerland.

22 0221

Convoglio pendolare NPZ delle SBB/FFS svizzere, prototipo RBDe4/4 «Colibri», con vagone pilota Bt 900, livrea verde chiaro/scuro. Altre versioni sono in preparazione.

Swiss Shuttle Service Train "Colibri" of SBB/CFF, prototype RBDe4/4 version in green, with dummy. Other colors and type-versions are released at a later date.



16 3911

CONVOGLIO PENDOLARE NPZ

Confezione «Micromodels» contenente un convoglio pendolare NPZ «Colibri» delle SBB; composto di quattro elementi:

- 22 0221 - carrozza pilota
- 32 0332 - carrozza centrale di 2^a classe
- 32 0332 - carrozza centrale di 2^a classe
- 22 0221D - carrozza pilota di coda, senza motore.

NEW₈₈

SHUTTLE SERVICE TRAIN

"Micromodels" set of NPZ "Colibri" train of SBB; consisting of four units:

- 22 0221 - powered front-end coach
- 32 0332 - 2nd class coach
- 32 0332 - 2nd class coach
- 22 0221D - dummy rear-end coach, with motor.



32 0328



32 0329



32 0880



...geri di 1ª classe,
...ederali Svizzere SBB-
...mm.
...ger coach, type A, of
...Railways SBB-CFF-
...mm.

...geri di 2ª classe,
...ederali Svizzere SBB-
...mm.
...ger coach, type B,
...Railways SBB-
...148 mm.

...geri con sopralzo
...ADum Trans-Eu-
...L. 165 mm.
...with observation
...rans-Europ "Pano-
...45 mm.



GERMANIA-GERMANY



22 0131

Carrozza centrale di 1°/2° classe. *First/second class coach.*

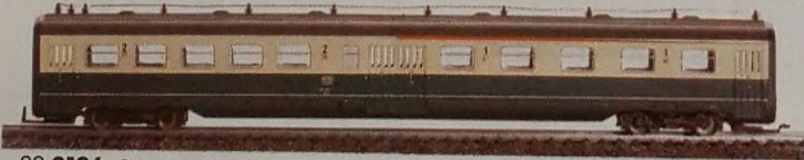

22 0136 Carrozza centrale di 1°/2° classe. *First/second class coach.*



22 0111

Carrozza centrale di 1° classe. *First class coach.*

22 0112

Carrozza centrale ristorante. *Restaurant coach.*



16 3907

ET 30

Confezione «Micromodels» contenente un elettrotreno serie ET 30 delle DB, nella livrea originaria rosso-grigio; composto di tre elementi:

22 **0130L** - carrozza-pilota di 2ª classe

22 **0131** - carrozza centrale di 1ª/2ª classe

22 **0132** - carrozza-pilota di 2ª classe, senza motore.

Il convoglio può essere integrato da uno o più elementi centrali

22 **0131** - acquistabili separatamente.

ET 30

«Micromodels» set of an electric train Class ET 30 of DB, in its original red-grey livery. Consisting of three units;

22 **0130L** - second class powered front-end coach.

22 **0131** - first/second class coach.

22 **0132** - dummy second class rear-end coach, without motor.

The train can be enlarged with one or more additional units 22 **0131**, separately available.



16 3908

Serie 430

Confezione «Micromodels» contenente un elettrotreno serie 430 delle DB, nella livrea turchese-crema; composto di tre elementi:

22 **0135L** - carrozza-pilota di 2ª classe

22 **0136** - carrozza centrale di 1ª/2ª classe

22 **0137** - carrozza-pilota di 2ª classe, senza motore.

Il convoglio può essere integrato da uno o più elementi centrali:

22 **0136**, acquistabili separatamente.

CLASS 430

«Micromodels» set of an electric train Class 430 of DB, in the new ivory-turquoise livery. Consisting of three units:

22 **0135L** - second class powered front-end coach

22 **0136** - first/second class coach

22 **0137** - dummy second class rear-end coach, without motor.

The train can be enlarged with one or more additional units 22 **0136**, separately available.



16 3902

LUFTHANSA AIRPORT EXPRESS

Confezione «Micromodels» contenente un elettrotreno serie ET 403/404 delle DB nell'originale livrea giallo-bianco, composto di quattro elementi:

22 **0110L** - carrozza-pilota. 22 **0111** - carrozza centrale di 1ª classe.

22 **0112** - carrozza centrale ristorante. 22 **0113** - carrozza-pilota, senza motore.

Il convoglio può essere integrato da altri due elementi centrali, 22 **0111** e 22**0112**, acquistabili separatamente.

LUFTHANSA AIRPORT EXPRESS

«Micromodels» set of an electric train Class ET 403/404 of DB in its original yellow-white livery. Consisting of four units:

22 **0110L** - first class powered front-end coach,

22 **0111** - 1st class coach, 22 **0112** - restaurant coach, 22 **0113** - dummy first class rear-end coach, without motor.

The train can be enlarged with two additional units, separately available.

16 3903

INTERCITY ET 403/404

Confezione «Micromodels» contenente un elettrotreno Intercity ET 403/404 delle DB nella tipica livrea bianco-nero-rosso; composto di quattro elementi:

22 0100L - carrozza-pilota di 1° classe. 22 0101 - carrozza centrale di 1° classe. 22 0102 - carrozza centrale ristorante. 22 0103 - carrozza-pilota di 1° classe, senza motore.

Il convoglio può essere integrato da altri due elementi centrali.

22 0101 e 22 0102 acquistabili separatamente.

INTERCITY ET 403/404

«Micromodels» set of an Intercity electric train Class ET 403/404 of DB in its typical white-black-red livery. Consisting of four units:

22 0100L - first class powered front-end coach, 22 0101 - 1st class coach, 22 0102 - restaurant coach, 22 0103 - dummy first class rear-end coach, without motor.

The train can be enlarged with two additional units, separately available: 22 0101 and 22 0102.



22 0102 Carrozza centrale ristorante. Restaurant coach.



32 0871

32 0871

Carrozza passeggeri a comparti di 1° classe tipo Avüm, per treni IC e T.E.E. delle Ferrovie Tedesche D.B. - L. 165 mm.

Passenger coach with 1st class compartments, type Avüm, for IC and TEE trains of the German Railways DB - Length 165 mm.



32 0872

32 0872

Carrozza passeggeri di 1° classe, tipo Apüm, per treni IC e T.E.E. delle Ferrovie Tedesche D.B. - L. 165 mm.

1st class passenger coach, type Apüm, for IC and TEE trains of the German Railways DB - Length 165 mm.



32 0873

32 0873

Carrozza ristorante, tipo Wrüm, per treni IC e T.E.E. delle Ferrovie Tedesche D.B. - L. 165 mm.

1st class dining coach, type Wrüm, for IC and TEE trains of the German Railways DB - Length 165 mm.



32 0874

32 0874

Carrozza passeggeri mista salone e comparti di 1° classe con sopralzo panoramico, tipo ADüm, per treno «Rheingold» delle Ferrovie Tedesche D.B. - L. 165 mm.

Composite passenger coach Pulman/1st class compartments, with observation top, type ADüm, for the Rheingold train of the German Railways DB - Length 165 mm.



0101 Carrozza centrale di 1° classe. *First class coach.*

0887
Carrozza passeggeri a comparti di
1° classe, tipo Avüm, per treni IC e
TEE delle Ferrovie Tedesche D.B. - L.
165 mm.
Passenger coach with 1st class com-
partments, type Avüm, for IC and TEE
trains of the German Railways DB -
Length 165 mm.



32 0887

0888
Carrozza ristorante, tipo Wrüm, per
treni IC e T.E.E. delle D.S.G. - L. 165
mm.
Restaurant coach, type Wrüm, for IC
and T.E.E. trains of the D.S.G. -
Length 165 mm.

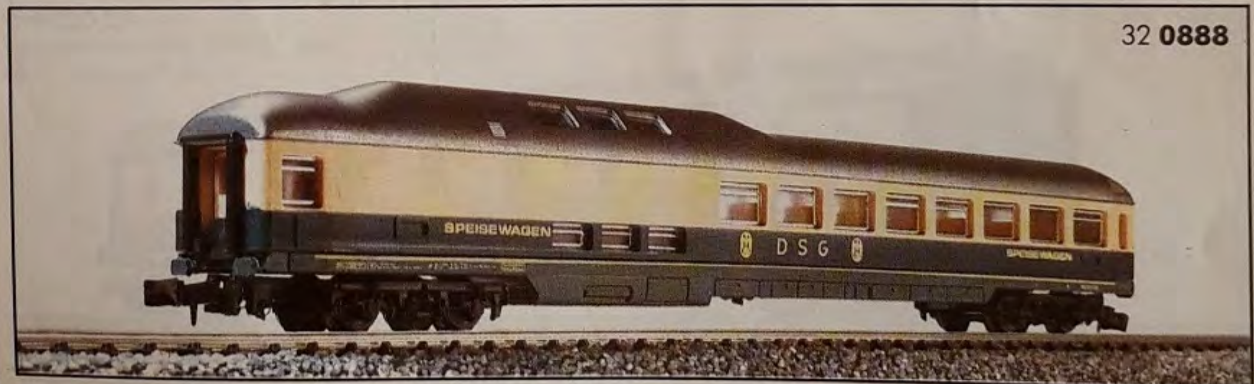

32 0888

0890
Carrozza passeggeri mista salone e
di 1° classe con sopralzo
per il treno «Rhein-
gold» delle D.B. - L. 165 mm.
Mist saloon and 1st class passenger coach Pul-
st class compartments, with
reclining top, type ADüm, for the
old train, of the D.B. - Length
165 mm.



32 0890

0889
Carrozza passeggeri di 1° classe, ti-
po Avüm, per treni IC e T.E.E. delle
Ferrovie Tedesche D.B. - L. 165 mm.
1st class passenger coach of 1st class, type
Avüm, for IC and TEE trains of the
German Railways D.B. - Length 165
mm.



32 0889



32 0303



C.I.W.L.T.

32 0303

Carrozza ristorante della «Compagnie Internationale des Wagons-Lits et du Tourisme» CIWLT, usata nella composizione del treno «Orient-Express» - L. 138 mm.

Dining coach utilized by the "Compagnie Internationale des Wagons-Lits et du Tourisme" (CIWLT) in particular for the train "Orient-Express" - Length 138 mm.

32 0304



32 0304

Carrozza passeggeri, tipo Pullman, usata dalla «Compagnie Internationale des Wagons-Lits et du Tourisme» CIWLT, specialmente nella composizione del treno «Orient-Express» - L. 138 mm.

Passenger coach, type Pullman, utilized by the "Compagnie Internationale des Wagons-Lits et du Tourisme" (CIWLT) in particular for the train "Orient-Express" - Length 138 mm.

32 0335



T.E.N.

32 0335

Carrozza letto, tipo WLAbm, del gruppo T.E.N., appartenente alle Ferrovie Italiane F.S. - L. 165 mm.

Sleeping coach, type WLAbm, of the group T.E.N., belonging to the Italian Railways F.S. - Length 165 mm.

32 0305



32 0305

Carrozza letto, tipo WLAsm, del gruppo T.E.N., appartenente alle Ferrovie Tedesche D.B. - L. 165 mm.

Sleeping coach type WLAsm, of the group T.E.N., belonging to the German Railways DB - Length 165 mm.

Particolarmente spettacolari in un treno merci sono i carri cisterna, predisposti non solo per il trasporto di prodotti petroliferi, ma anche di prodotti chimici, di gas compressi o liquefatti e infine di liquidi alimentari. A fianco dei ben noti carri a due assi, sono entrati in servizio negli ultimi anni anche i vagoni a carrelli di grande capacità.

They are probably the most impressive wagons in a freight train. They are designed to ensure the transportation of oil products, chemicals, compressed or liquified gases as well as alimentary liquids. In addition to the conventional fourwheel wagons, new big-capacity bogie wagons were recently introduced and they can be used to compose an entire freight train, thanks also to the much improved horsepower of the modern locomotives.

32 0451
Carro serbatoio, tipo Uh «ESSO» - L. 65 mm.
Tank wagon «ESSO», type Uh - Length 65 mm.

32 0620
Carro serbatoio tipo Uah, a 4 assi «MOBIL OIL» - L. 87 mm.
4 axle tank wagon «MOBIL OIL», type Uah - Length 87 mm.

32 0621
Carro serbatoio, tipo Uah, a 4 assi «SHELL» - L. 87 mm.
4 axle tank wagon «SHELL», type Uah - Length 87 mm.



32 0734



32 0730



32 0451



32 0620



32 0621



per il trasporto di
granaglie, farina, ce-
menti, sono costituiti da un pia-
nello montati due o
tre verticali intercomunican-
ti dall'alto.
They are used for transpor-
ting homogeneous materials
such as cereals, flour, cement.
On a flat wagon, upon
which vertical bins are

automatico «OMYA»
automatic unloading
length 56 mm.

automatico «EVS» -
automatic unloading
length 56 mm.

automatico delle
-Lits
automatic unloading, of
length 56 mm.

omp
s Lits
icula

nan,
atio-
rism
posi
s» - L

o, util
ation
me"
ain
mm.

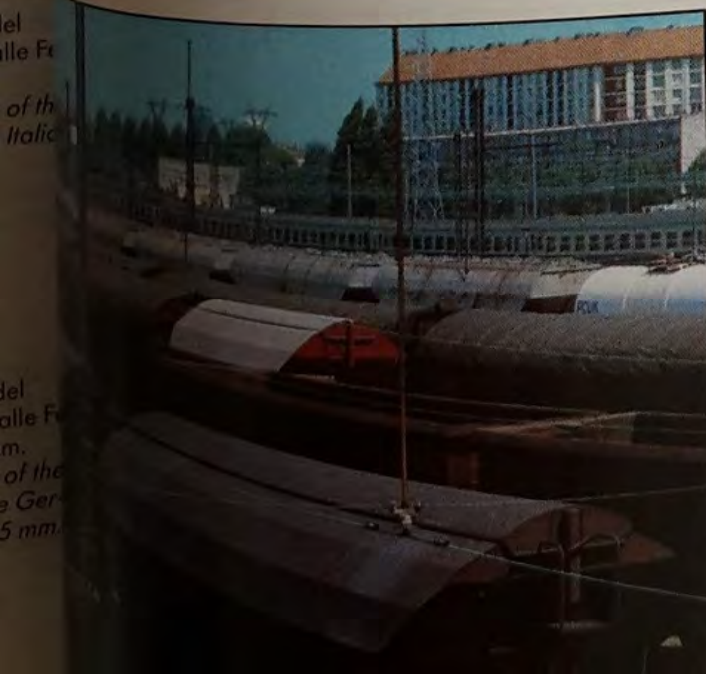

32 0403



32 0404



32 0640



32 0457



32 0403

Carro scoperto a sponde alte tipo Omm, delle F.S. - L. 65 mm.
Open wagon with side boards, type Omm, of the F.S. - Length 65 mm.

32 0404

Carro scoperto a sponde alte tipo Omm, delle F.S. carico di carbone - L. 65 mm.
Open wagon with side boards and with coal, type Omm, of the F.S. - Length 65 mm.

32 0727

Carro scoperto a sponde alte tipo Omm, delle S.N.C.F. - L. 65 mm.
Open wagon with side boards, type Omm, of the S.N.C.F. - Length 65 mm.

32 0640

Carro scoperto a sponde alte tipo Eaos, delle D.B. - L. 85 mm.
Open wagon with side boards, type Eaos, of the D.B. - Length 85 mm.

32 0457

Carro per trasporto sabbia Eaos, E81 - L. 85 mm.
Open wagon with side boards, type Eaos, E81 - Length 85 mm.

32 0642

Carro scoperto a sponde alte tipo Eaos, delle SBB-CFF-FFS - L. 85 mm.
Open wagon with side boards, type Eaos, of the SBB-CFF-FFS - Length 85 mm.

32 0456

Carro refrigerante tipo lbces «STEF» - L. 70 mm.
Refrigerator wagon "STEF", type lbces - Length 70 mm.

32 0464

Carro refrigerante, tipo lbces, «Interfrigo» - L. 70 mm.
Refrigerator wagon "Interfrigo", type lbces - Length 70 mm.

32 0479

Carro refrigerante a 2 assi «Coca-Cola» - L. 70 mm.
2 axle refrigerator wagon "Coca-Cola" - Length 70 mm.

32 0469

Carro refrigerante a 2 assi «Spatenbräu» - L. 70 mm.
2 axle refrigerator wagon "Spatenbräu" - Length 70 mm.

32 0642



32 0456



32 0464



32 0479



32 0469





32 0735



32 0736

WAGONS

po...
mi...
ty...
gh...
... delle
... Z², delle
... 65 mm.
... Z², of the
... 65 mm.

STE...
oe...
... della Compa-
... L. 65 mm.
... of the compa-
... 65 mm.

WAGONS

o", l...
... tipo Fad 167,
... "RAG", type Fad 167

oca...
oca...
... tipo Fad 167,
... "SGW", type Fad 167

spate...
pate...
PORTI

WAGONS

046...
... trasporto conteni-
... HAPAG/LLOYD - L.

... transport of con-
... HAPAG/LLOYD

... con bilico
... L. 136 mm.
... Length 136

2 04...
... due piani, li-
... L. 154 mm.

... trasporti auto-
... type Laes -

... due piani

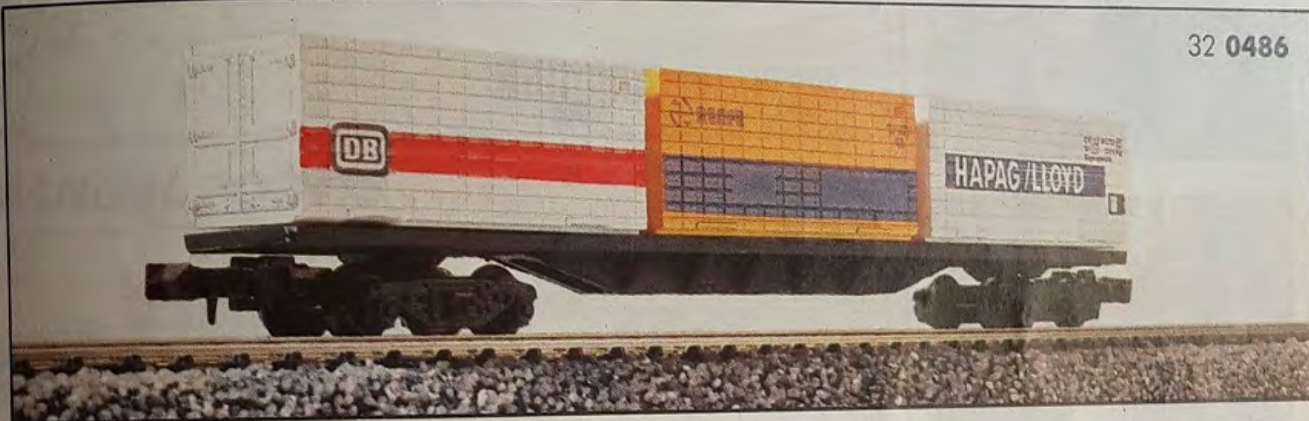

32 0486

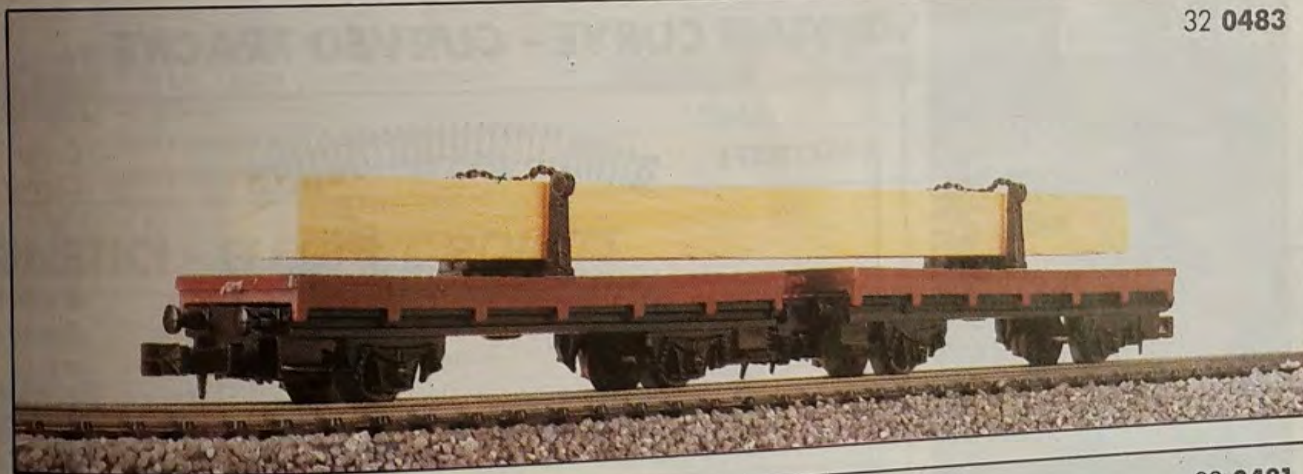

32 0483

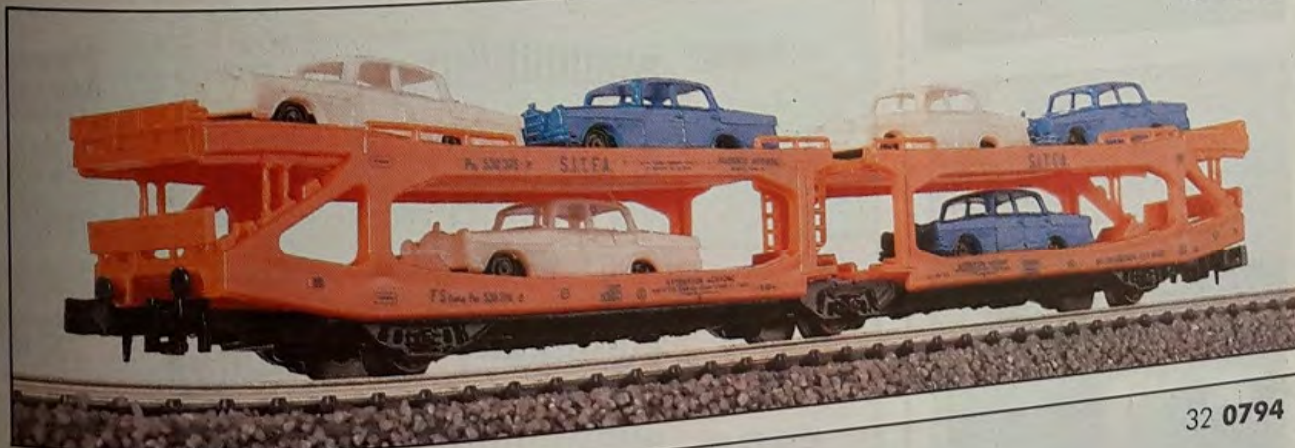

32 0481



32 0794

ROTAIE DIRITTE - STRAIGHT TRACKS

- | | | |
|----------|--|--|
| 42 0560 | | Diritto L. 249 mm. - In scatola da 12 pz.
Straight L. 249 mm. - Box 12 pcs. |
| 42 0561 | | Diritto L. 124 mm - In scatola da 12 pz.
Straight L. 124 mm. - Box 12 pcs. |
| 42 0562 | | Diritto L. 62,25 mm - In scatola da 12 pz.
Straight L. 62,25 mm - Box 12 pcs. |
| 42 0564 | | Diritto con attacco corrente L. 62,25 mm. - In scatola da 12 pz.
Straight with power clip L. 62,25 mm - Box 12 pcs. |
| 42 0564R | | Diritto con interruzione unipolare a contatto L. 62,25 mm. - In scatola da 12 pezzi.
Straight Isolating L. 62,25 mm - Box 12 pcs. |
| 42 0565 | | Terminale L. 62,25 mm - In scatola da 6 pezzi.
Buffer stop 62,25 mm - Box 6 pcs. |
| 42 0563 | | Diritto L. 31,12 mm - In scatola da 12 pezzi.
Straight L. 31,12 mm - Box 12 pcs. |

ROTAIE CURVE - CURVED TRACKS

- | | | |
|----------|--|--|
| 42 0571 | | Curvo Ø 406 mm 45° - In scatola da 12 pz.
Curved Ø 406 mm. 45° - Box 12 pcs. |
| 42 0571C | | Curvo Ø 406 mm 45° con attacco corrente - In scatola da 12 pz.
Curved Ø 406 mm 45° w/power clip. Box 12 pcs. |
| 42 0572 | | Curvo Ø 406 mm 15° - In scatola da 12 pz.
Curved Ø 406 mm 15° - Box 12 pcs. |
| 42 0551 | | Curvo Ø 472 mm 30° - In scatola da 12 pz.
Curved Ø 472 mm. 30° - Box 12 pcs. |
| 42 0552 | | Curvo Ø 472 mm. 15° - In scatola da 12 pz.
Curved Ø 472 mm 15° - Box 12 pcs. |
| 42 0575 | | Curvo Ø 538 mm 45° - In scatola da 12 pz.
Curved Ø 538 mm 45° - Box 12 pcs. |
| 42 0575C | | Curvo Ø 538 mm 45° con attacco di corrente - In scatola da 12 pz.
Curved Ø 538 mm 45° with power clip - Box 12 pcs. |

FLESSIBILE - FLEXIBLE

- | | | |
|---------|--|---|
| 42 0511 | | Flessibile L. 736 mm - In scatola da 12 pz.
Flexible L. 736 mm - Box 12 pcs. |
|---------|--|---|

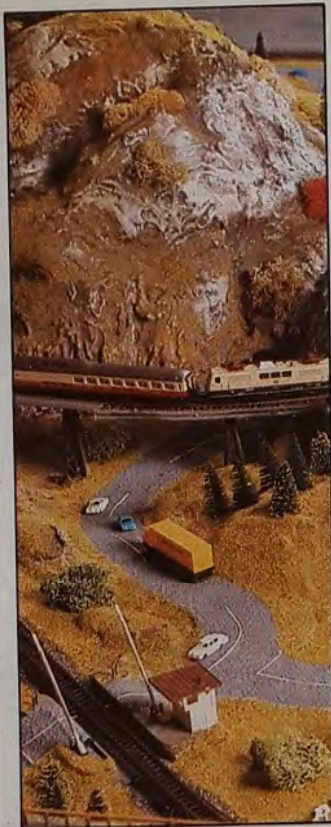



Incrocio destro 15° - In scatola da 2 pz.
Right diamond crossing 15° - Box 2 pcs.

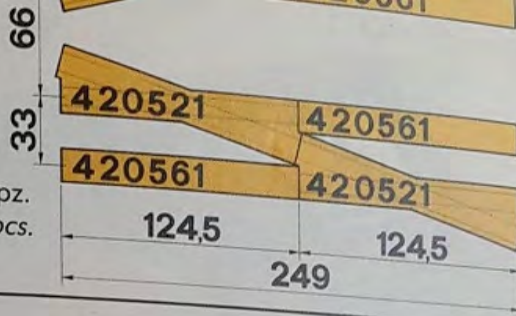

30° - CROSSING 30°



Incrocio a 30° - In scatola da 2 pz.
Diamond crossing 30° - Box 2 pcs.

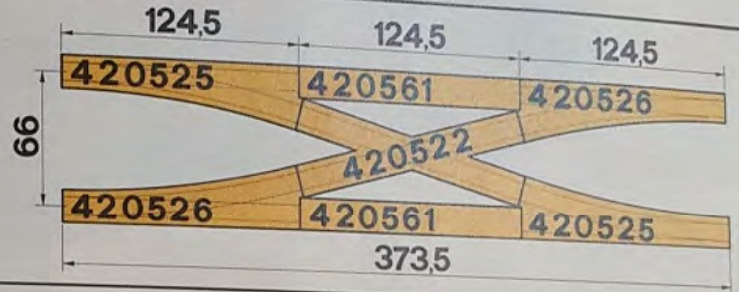

MANUALI - MANUAL POINTS



Scambio a mano destro - In scatola da 2 pz. e compensazione 42 **0553**.
Right manual point - Box 2 pcs + 2 pcs compensating 42 0553

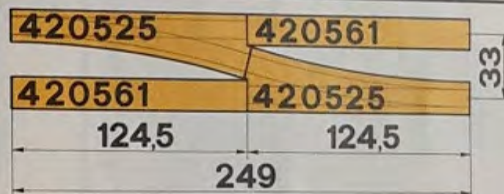

Scambio a mano sinistro - In scatola da 2 pz. + 2 compensazioni 42 **0553**.
Left manual point - Box 2 pcs + 2 pcs compensating track 42 0553

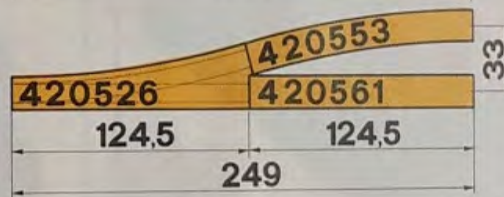

ELETTROMAGNETICI - ELECTRIC POINTS



Scambio elettromagnetico destro - In scatola da 2 pz + 2 compensazioni 42 **0553**.
Right electric point - Box 2 pcs + 2 pcs compensating track 42 0553.

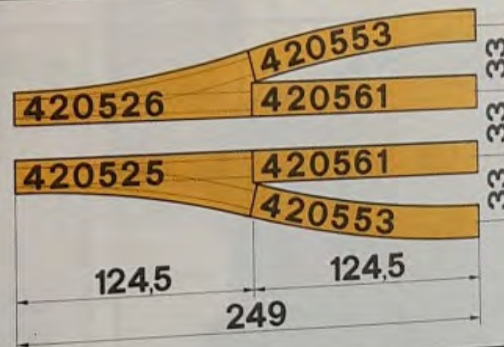

Scambio elettromagnetico sinistro. In scatola da 2 pz + 2 compensazioni 42 **0553**.
Left electric point - Box 2 pcs + 2 pcs compensating track 42 0553.

DI COMPENSAZIONE SATING TRACK



Compensazione dello scambio.
Compensating.

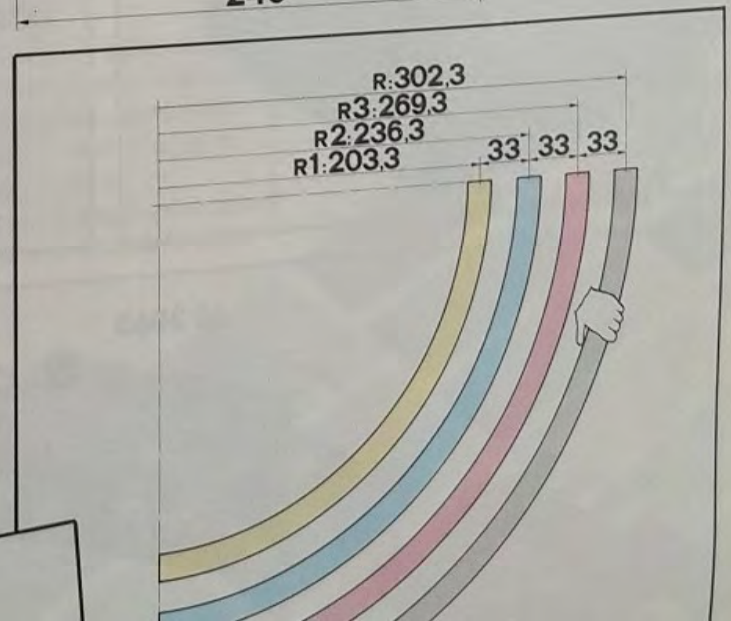

TRASFORMATORI POWER CONTROLLERS

60 2060



60 2060

Trasformatore per due treni e scambi ed accessori elettrici. Alimentazione a 220 V. Tensione disponibile in corrente continua 0-12 V. a 1,2 A. Tensione disponibile in corrente alternata 14 V. a 1,2 A. Protezione contro i corto circuiti a disgiuntore termico.

Transformer for two trains, points and electric accessories. Power 220 V; 50-60 Hz. The tension is controlled electronically for an output in direct current from 0-12 V=7,5 V.A.

Tension available in alternated current 14 V.-12 V.A. Protected against short-circuit by thermal output.

60 2052

Trasformatore. Potenza 3,6 V.A. Tensione d'alimentazione 220 Volt. Tensione disponibile per la trazione 0-12 Volt in corrente continua. Questo trasformatore è stato realizzato per il funzionamento di un treno o per accessori a corrente continua.

Transformer. Power 3,6 V.A. Input 220 V. AC. Output 0-12 V DC. Designed to operate one train or DC accessories.

60 2053

Trasformatore per due treni e scambi ed accessori elettrici. Alimentazione a 220 V. Tensione disponibile in corrente continua 0-12 V. a 0,7 A. Tensione disponibile in corrente alternata 14 V. a 0,5 A.

Transformer for two trains, points and electrical accessories. Input 220 V. Output 0-12 V at 0.7 VA DC. AC output 14 V at 0.5 A.

60 2055

Trasformatore per dispositivi elettromagnetici. Tensione di alimentazione in corrente alternata a 220 V. Uscita 10 Volts alternata. Potenza V.A. 7.

Transformer for electromagnetic devices. Input 220 V 50-60 Hz AC. Output 10 V AC. Power 7 VA.

60 2050F

Cavo di collegamento con morsetti di sicurezza trasformatore-binario.

Connection cable with safety clamps transformer-traks.

60 2052



60 2053



60 2055



60 2050F



60 3065

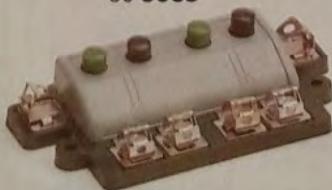

60 3067



60 3066

60 3065

Pulsantiera.
Switch shunter.

60 3066

Scatola di derivazione.
Push-button control box.

60 3067

Interruttore deviatore.
Junction box.

Although built with high-quality standards and strictly maintenance-free, LIMA locomotives can require the replacement of some worn parts during their long operation lifetime. The spare parts catalogue, carefully elaborated on fully updated cards, allows rapid recognition of the item reference number, while special blister-packed boxes ensure that LIMA parts are strictly genuine.



VIA GIOVANNI IMPERIALI 77 - 36100 VICENZA (ITALY)

SCALA HO Confezioni in blister HO SCALE Blister



3x60 0875
Spazzole e molle
per motore.
*Motor springs and
brushes.*



3x60 0876
24 giunti metallici.
*24 metal fish pla-
tes.*



3x60 0874
Clips.



3x60 0870
4 assali
Axles
Ø 11,5 mm.



3x60 0877
Giunti isolanti.
*Insulating fish pla-
tes.*



3x60 0869
4 assali
Axles
Ø 10,3 mm.

SERVICE BOX SERVICE BOX

Gli specialisti LIMA ti garantiscono una completa assistenza. Il service box, in loro dotazione, contiene i principali pezzi di ricambio per le parti di maggior usura.
The service box contains spare parts for repair and is available to LIMA stockist.

SCALA N Confezioni in blister N SCALE Blister



3x62 0718
24 punti in metal-
lo.
*24 metal fish pla-
tes.*



3x62 0704
Spazzole a molle
per motore.
*Motor spring and
brushes.*



3x62 0717
Giunti isolanti.
*Insulating fish pla-
tes..*



3x62 0703
4 assali.
4 axles.

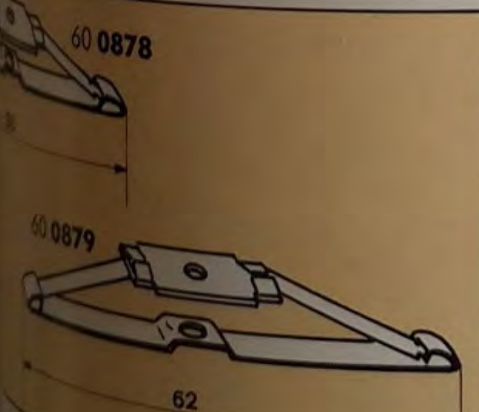
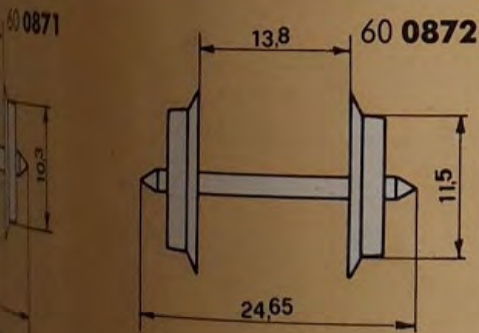

60 0878
Pattino di presa corrente L. 50 mm.
Contact rail shoe. Length 50 mm.





638805

Printed in Italy
Imprimé en Italie