

N SCALE TRACK FACTS

ATLAS N SCALE TRACK – THE WISE CHOICE

With over 30 years experience designing, producing and perfecting N Scale products, Atlas has developed a worldwide reputation as a premier track maker. Our affordable track and switches are made from injection-molded plastic and nickel silver rail to ensure the highest quality, precision, reliability and performance, following the tradition of excellence begun by our founder, Stephen J. Schaffan, Jr. some 60 years ago. His creation and patenting of flexible track, “switch kits” and more set early industry standards, enhancing model railroading for millions and earning him a place of honor in the Model Railroad Industry Hall of Fame.

Every piece of finely engineered Atlas N Scale track continues that legacy. No wonder it's the choice of experts worldwide! From our highly regarded, extensive Code 80 and Code 55 track lines, to our newest innovation in N Scale, Code 65 N True-Track®, the minds of Atlas continue to produce the track model railroaders need and desire to set their layouts apart, and ensure smooth operation time after time.

UNDERSTANDING THE DIFFERENCE BETWEEN CODE 80 AND CODE 55 TRACK

N Scale Code 80 (Black Ties/Solid Nickel Silver Rail)

This time-tested, “traditional” Atlas standard is sturdy, durable and available in an extensive line that includes Snap-Track®, Snap-Switches, Super-Flex® Track, crossings, wyes and more.

N Scale Code 55 (Brown Ties/Solid Nickel Silver Rail)

Termed “tried and true” by industry experts, Code 55 track has a lower rail profile than Code 80, with the same dependable performance and flexibility. Designed for the scale modeler, its prototypical ties and rails will enhance your layout's appearance and operation.

NOTE: Some owners of older rolling stock may experience difficulties with Code 55 track due to wheels that do not comply with modern NMRA standards. This is simply rectified by fitting such cars with a low-profile wheel set, such as Atlas Item #22134.

(See Atlas' new N Scale Code 65 ready-to-run roadbed True-Track® on p. 17)



*(Black ties, nickel silver rail)
Code 80*

BEGINNING YOUR N SCALE LAYOUT

Atlas makes it easy to start and finish with success. Begin by choosing a location, size and shape for your layout. Ideas abound on pages 22-23 and 29-33 in this catalog! Simply choose a layout and you're ready to go! Or you can download our popular RTS layout planning software FREE!

Visit www.atlasrr.com for more details.

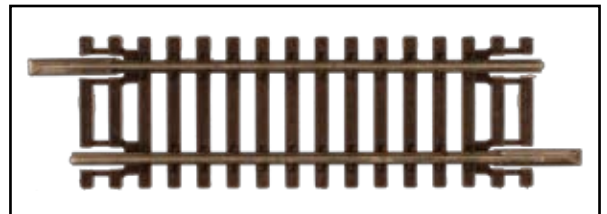

(Brown ties, nickel silver rail) Code 55

Atlas' Right Track Software 8.0 - This convenient and clear-cut layout planning program allows modelers of all experience levels to design a layout using electronic templates of Atlas track, switches, bridges, turntables, buildings and electrical controls – free of charge! Featuring 3-D landscape creation, terrain design techniques, drawing tools, short-circuit detection and information on converting to Flex-Track®, it provides a wealth of information on all phases of layout-building.



Print out your final plan and use it as a blueprint while you build your railroad! The software will record the products you use to make shopping easier, whether at your hobby shop or in our online store.

Download our popular layout planning software **FREE!**
Visit our web site for more details.

HOBBY STORE LOCATOR: [HTTP://LOCATOR.ATLASRR.COM](http://locator.atlasrr.com)

N

N TRUE-TRACK[®]

N TRUE-TRACK[®] READY-TO-RUN ROADBED TRACK

The latest addition to Atlas' highly regarded track line comes with Code 65 rail, which is smaller than similar track currently on the market, enhancing the track's scale look while at the same time allowing equipment to operate flawlessly. Ties are dark brown for a prototypical look and tie spacing matches the US prototype. Experience the unparalleled realism of its simulated ballast roadbed in gray with mottled color highlights. Six items are now available and are sure to please those modelers that appreciate maximum realism on their layout. Find out more information at www.atlasrr.com/trackmisc/ncode65truetrack.htm



Item #2491 - Terminal Rail Joiners

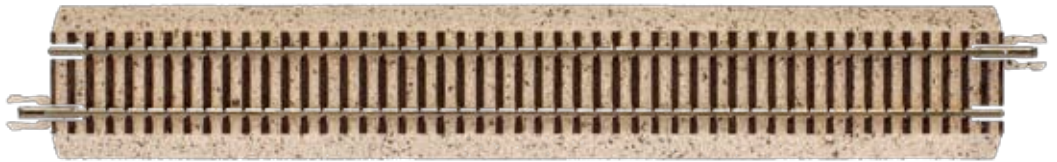

Item #2401 - 6" Straight

6"

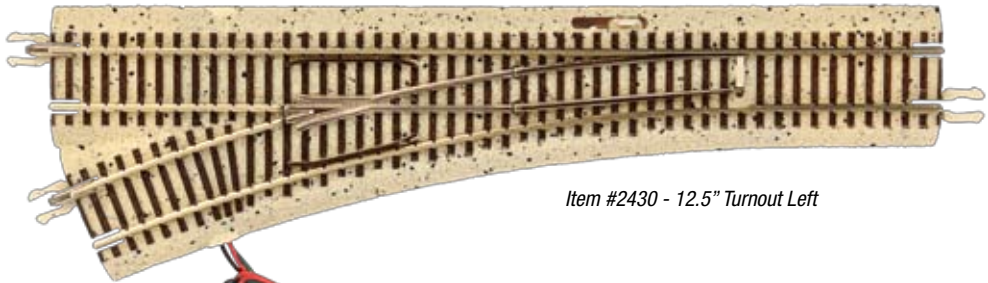

Item #2430 - 12.5" Turnout Left



Item #2492 - Insulated Rail Joiners



Item #2404 - 2" Straight

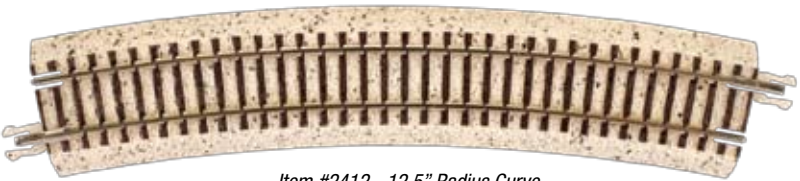

Item #2412 - 12.5" Radius Curve



Item #2490 - Rail Joiners

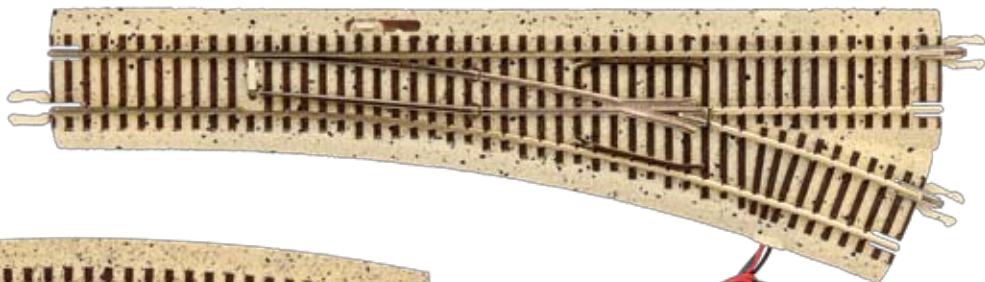

Item #2431 - 12.5" Turnout Right

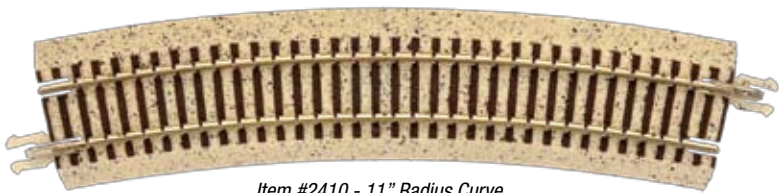

Item #2410 - 11" Radius Curve



NEW!

To order, please find a dealer near you at <http://locator.atlasrr.com>. For more ordering information and pricing, please see the price list inserted in this catalog.

HOBBY STORE LOCATOR: [HTTP://LOCATOR.ATLASRR.COM](http://locator.atlasrr.com)

N CODE 55 TRACK

CODE 55 TRACK – THE “MODELER’S TRACK”

N Scale Code 55 track, with its simulated wood brown ties and smaller solid nickel silver rail, is the choice of discriminating modelers who desire a more prototypical look on their layouts. Using sophisticated technology, Atlas has engineered the ultimate in precision track, praised for its superior design and ease of use. In N Scale, Atlas offers one of the largest selections of sectional track and turnouts on the market today.

“Atlas track uses their tried-and-true approach of one fixed rail and one sliding rail, making it very easy to fit Atlas Flex-Track to nearly any radii...it can be easily straightened...it is nearly self-straightening. There is no doubt that Code 55 is visually closer to prototypical rail...”

Model Railroad News, September 2006

Item #2000 -
Code 55 Super-Flex®
Track

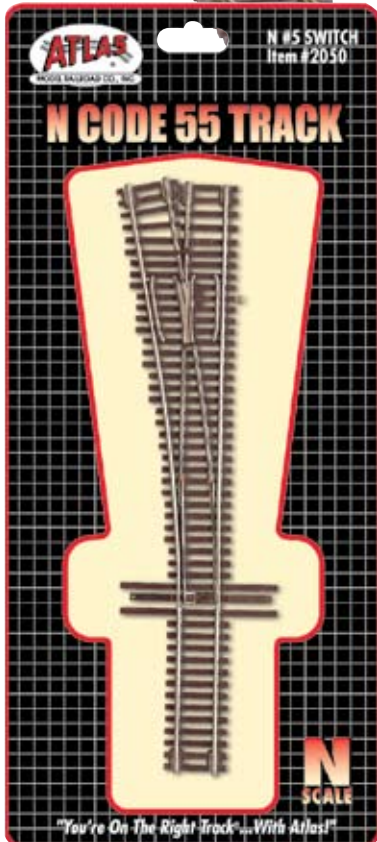

Item #2001 - 6" Rerailer



Item #2003 - 4.25" Straight



Item #2004 - 3" Straight



Item #2005 - 2" Straight



Item #2006 - 1.25" Straight



Item #2007 - 1" Straight



Item #2002 -
6" Straight

Item #2008 - .75" Straight

**“You’re On The
Right Track...With
Atlas!®”**

To order, please find a dealer near you at <http://locator.atlasrr.com>.
For more ordering information and pricing, please see the price list
inserted in this catalog.

HOBBY STORE LOCATOR: [HTTP://LOCATOR.ATLASRR.COM](http://locator.atlasrr.com)

N CODE 55 TRACK

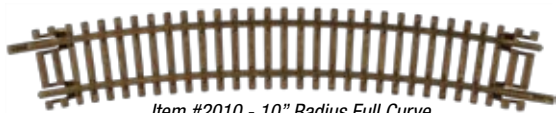

Item #2010 - 10" Radius Full Curve



Item #2029 - 21.25" Radius Half Curve



Item #2012 - 11.25" Radius Full Section



Item #2027 - 20" Radius Half Curve



Item #2014 - 12.5" Radius Full Section



Item #2025 - 18.75" Radius Half Curve



Item #2016 - 13.75" Radius Full Section



Item #2023 - 17.5" Radius Half Curve



Item #2018 - 15" Radius Full Section



Item #2021 - 16.25" Radius Half Curve



Item #2020 - 16.25" Radius Full Section



Item #2019 - 15" Radius Half Curve

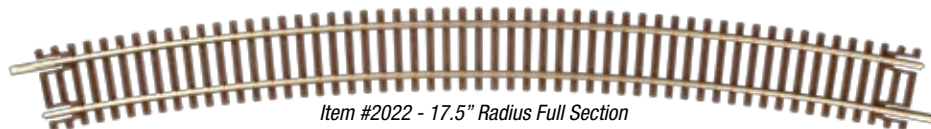

Item #2022 - 17.5" Radius Full Section



Item #2017 - 13.75" Radius Half Curve

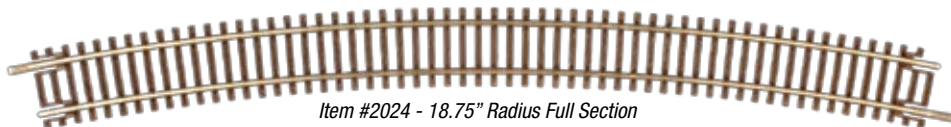

Item #2024 - 18.75" Radius Full Section



Item #2015 - 12.5" Radius Half Curve

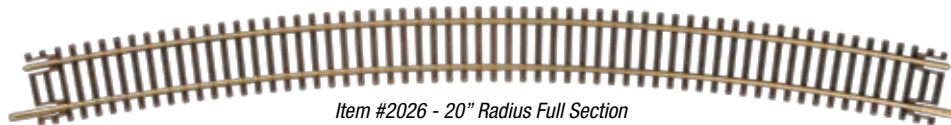

Item #2026 - 20" Radius Full Section



Item #2013 - 11.25" Radius Half Curve



Item #2028 - 21.25" Radius Full Section



Item #2011 - 10" Radius Half Curve

To order, please find a dealer near you at <http://locator.atlasrr.com>. For more ordering information and pricing, please see the price list inserted in this catalog.

HOBBY STORE LOCATOR: [HTTP://LOCATOR.ATLASRR.COM](http://locator.atlasrr.com)

N CODE 55 TRACK



Item #2030 - 30.609" Radius Section



Item #2031 - 71" Radius Curve

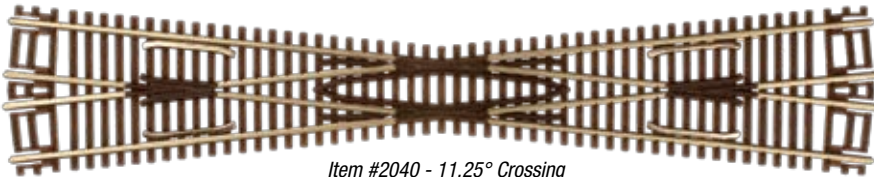

Item #2040 - 11.25° Crossing



Item #2041 - 22.5° Crossing

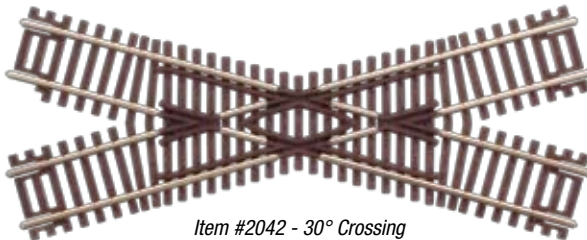

Item #2042 - 30° Crossing



Item #2043 - 45° Crossing

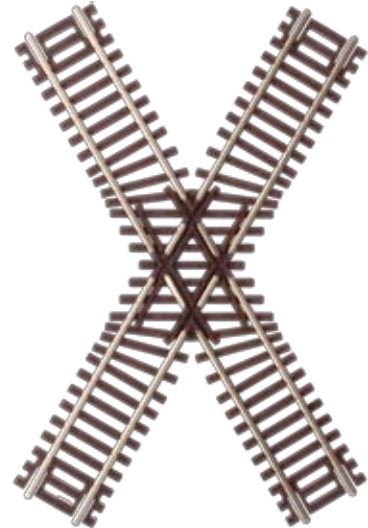

Item #2044 - 60° Crossing

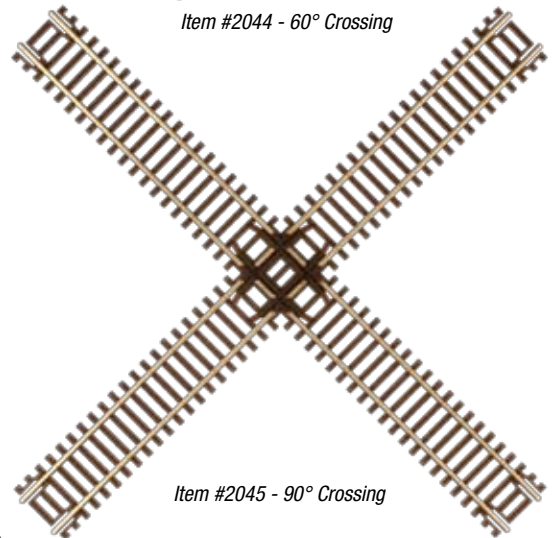

Item #2045 - 90° Crossing

N CODE 55 SWITCH MACHINE

For use with Atlas Code 55 track, this switch machine comes with a double-pole, double-throw relay with actuating mechanism. It can face in either direction for ease of use. Nicely placed beneath your layout so you can throw your switches without being seen.



Item #2065 -
Under-Table Switch Machine

Note: Combined thickness must not exceed 1-5/8".

To order, please find a dealer near you at <http://locator.atlasrr.com>. For more ordering information and pricing, please see the price list inserted in this catalog.

HOBBY STORE LOCATOR: [HTTP://LOCATOR.ATLASRR.COM](http://locator.atlasrr.com)

N CODE 55 TRACK

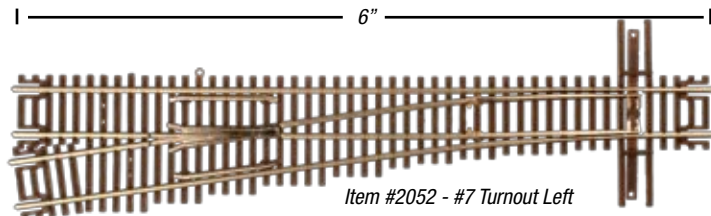
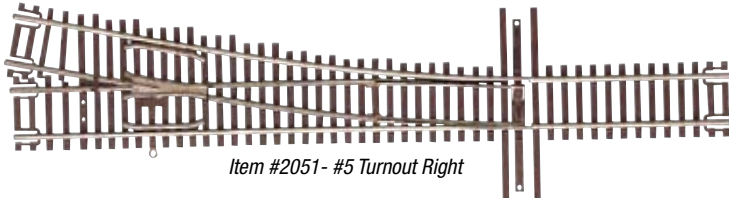
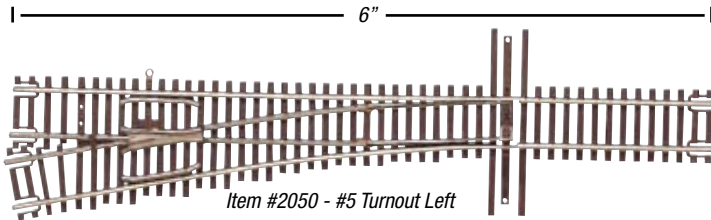

Item #2056 - #2.5 Wye Turnout

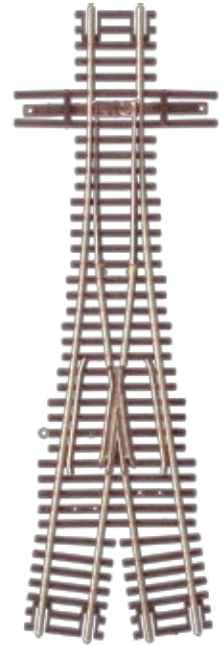

Item #2057 - #3.5 Wye Turnout

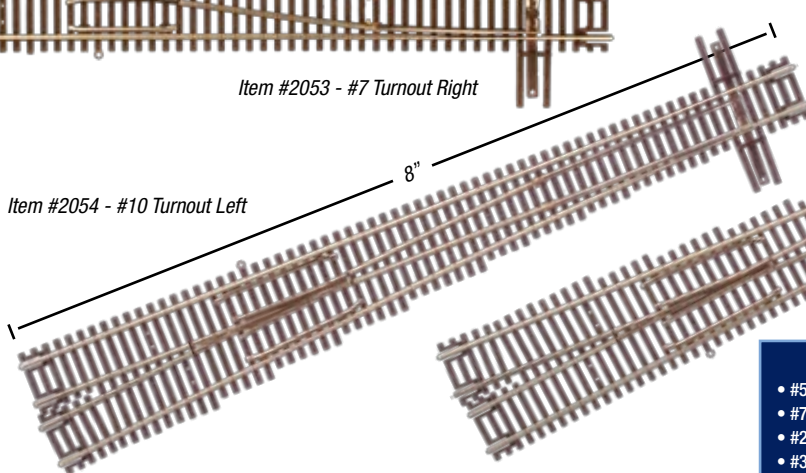

Item #2055 - #10 Turnout Right

Code 55 Turnout Angles

- #5 (Item #2050, 2051) Turnout Angle = 11° 25' (11.42°)
- #7 (Item #2052, 2053) Turnout Angle = 8° 10' (8.17°)
- #2.5 Wye (Item #2056) Turnout Angle = 22° 30' (22.50°)
- #3.5 Wye Turnout (Item #2057) Turnout Angle = 16° 15' (16.26°)
- #10 (Item #2054, 2055) Turnout Angle = 5° 43' (5.72°)



Item #2059 - 21.25" Radius Turnout Right



To order, please find a dealer near you at <http://locator.atlasrr.com>. For more ordering information and pricing, please see the price list inserted in this catalog.

HOBBY STORE LOCATOR: [HTTP://LOCATOR.ATLASRR.COM](http://locator.atlasrr.com)

N CODE 55 TRACK LAYOUTS

CHOOSING A LAYOUT

1. REVIEW THE LAYOUTS

This catalog gives you a basic overview of every railroad plan currently offered by Atlas. Once you have decided which layout fits your scale, skill level, size and price range (see price list inserted into this catalog), you will be ready to purchase the layout. Do not attempt to construct a layout by using this catalog only.

2. OBTAIN YOUR LAYOUT

Each layout can be found on our web site at www.atlasrr.com

3. PURCHASE THE LAYOUT

Atlas products are sold worldwide in hobby shops, as well as on our online store. Developing a relationship with your local hobby shop can enhance and assist your model railroading experience. Utilizing the advanced Atlas International Dealer Locator on our website (below), you can view and download directions to hobby shops in your area. If you choose not to buy all components at once, you could divide the layout into independent sections, then expand your railroad at your discretion.

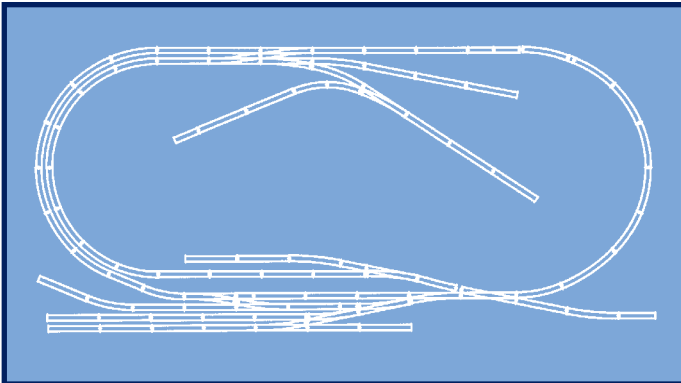

N-501 BREWSTER & MILLSTONE

From web site: www.atlasrr.com

Minimum Table Size Required: 3' x 6'

N Scale Item #N-501

Products Required: Super-Flex® track section, straight sections, radius sections, turnouts, bumpers, insulated joiners, terminal joiners and a Selector

The Brewster & Millstone provides lots of action in a small amount of space. This plan allows you to run through freights, local freights and a switching yard all in a 3' x 6' space! An exceptional layout for the modeler who wants to have it all.

N-502 NEEDHAM JUNCTION

From web site: www.atlasrr.com

Minimum Table Size Required: 18" x 96"

N Scale Item #N-502

Products Required: Straight sections, radius sections, turnouts, a crossing, bumpers, insulated joiners, terminal joiners and a Selector

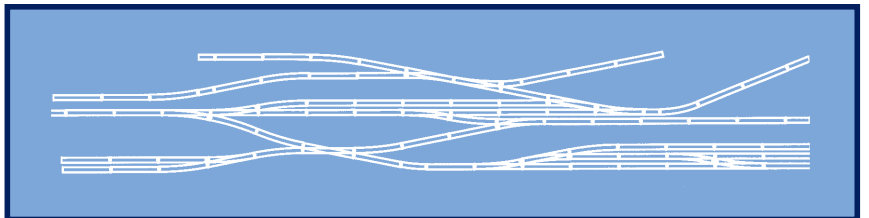

A great layout for the modeler who has a narrow or shelf working space! This 18" x 96" switching layout is a match for someone who likes a challenge in switching operations. The Needham Junction includes an interchange/yard, as well as a small switchback, that is sure to make any operating session an interesting one.

To order, please find a dealer near you at <http://locator.atlasrr.com>. For more ordering information and pricing, please see the price list inserted in this catalog.

HOBBY STORE LOCATOR: [HTTP://LOCATOR.ATLASRR.COM](http://locator.atlasrr.com)

N CODE 55 TRACK LAYOUTS

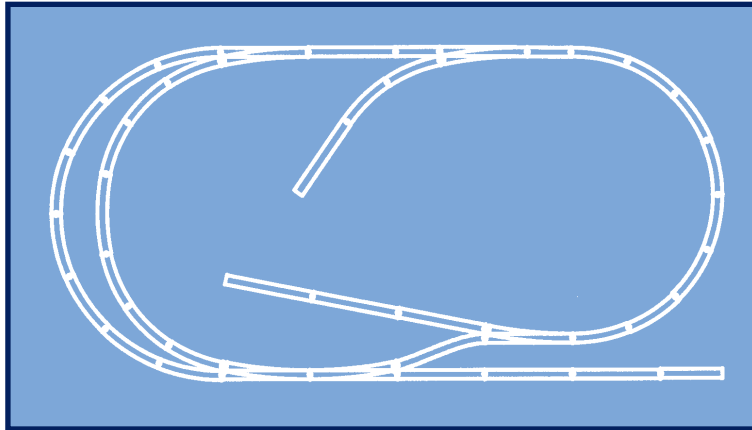

N-503 NARRANGANSETT BAY

From web site: www.atlasrr.com

Minimum Table Size Required: 2' x 4'

N Scale Item #N-503

Products Required: Super-Flex® track section, straight sections, radius sections, turnouts, insulated joiners, terminal joiners, bumpers and a selector

Similar to the Brewster & Millstone, this small but busy layout provides plenty of activity in a minimum amount of space, it is a perfect layout for someone who likes switching and running trains in loops. It has the room for a long train, allowing the modeler to showcase their locomotives and freight car fleet.

N-504 PLATTSBURG PRETZEL

From web site: www.atlasrr.com

Minimum Table Size Required: 2' x 5'

N Scale Item #N-504

Products Required: Straight sections, radius sections, turnouts, a crossing, terminal joiners, bumper and a selector

Take an ordinary oval track, twist one end and you have one of the most popular track plan elements: the Figure 8. The Plattsburg Pretzel is a Figure 8, keeping its operation interesting by making the train appear to reverse its direction as it proceeds. This layout also adds interest by adding a spur for more train enjoyment.

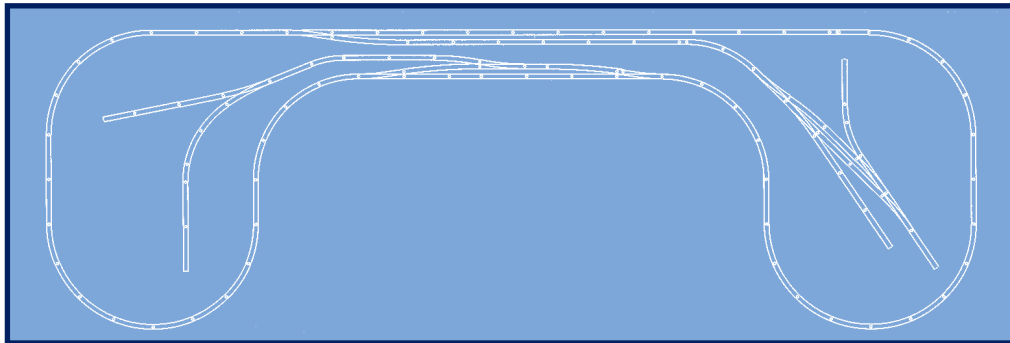
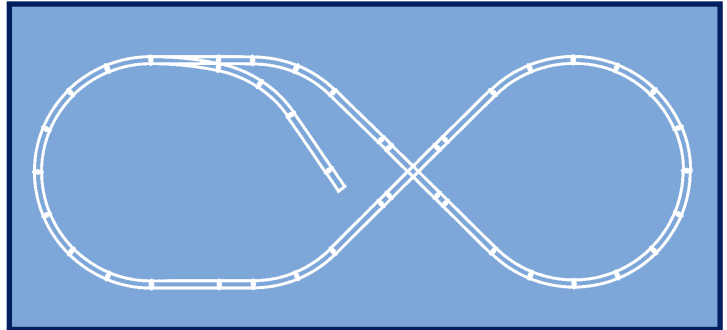

N-505 NAUSET VALLEY RAILWAY

From web site: www.atlasrr.com

Minimum Table Size Required: 11'-6" x 3'-6"

N Scale Item #N-505

Products Required: Super-Flex® track section, straight sections, radius sections, turnouts, a crossing, insulated joiners, terminal joiners, bumpers and a selector

The 11'-6" x 3'-6" Nauset Valley Railway is designed for long main line running along with intricate switching. This "Dog Bone" style layout will provide modelers with plenty of work to do between running long through freights and working the local!

To order, please find a dealer near you at <http://locator.atlasrr.com>. For more ordering information and pricing, please see the price list inserted in this catalog.

HOBBY STORE LOCATOR: [HTTP://LOCATOR.ATLASRR.COM](http://locator.atlasrr.com)

N CODE 80 TRACK

N CODE 80 TRACK - BLACK TIES & NICKEL SILVER RAIL!

Our popular N Scale Code 80 track has been used on thousands of model railroads over the last 30 years. Easy to use and affordable, you will find that Atlas N Scale Code 80 track, with black ties and nickel silver rail, is built to last for ultimate performance.

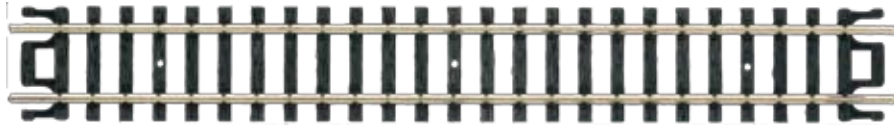

Item #2501 - 5" Straight Snap-Track® Section



Item #2509 - Straight Snap-Track® Assortment

Includes two 2-1/2", four 1-1/4" and four 5/8" sections.
Provides you with an easy way to fill short gaps in sectional track layouts.

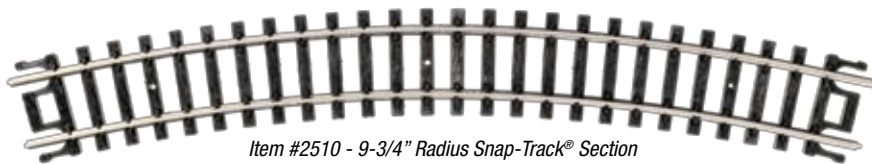

Item #2510 - 9-3/4" Radius Snap-Track® Section

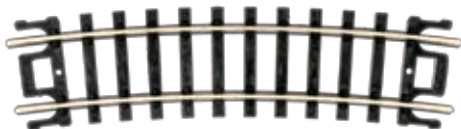

Item #2511 - 1-2-9 3/4" Radius Snap-Track® Section

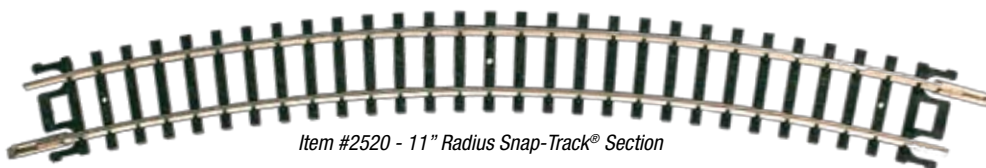

Item #2520 - 11" Radius Snap-Track® Section

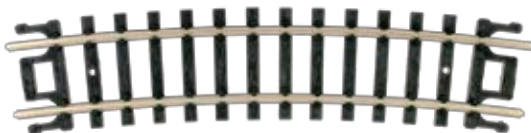

Item #2521 - 1-2-11" Radius Snap-Track® Section

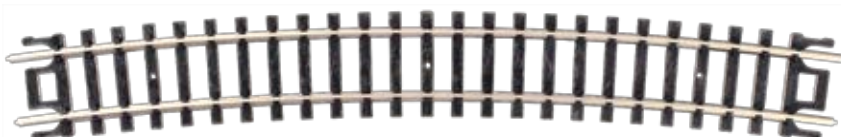

Item #2526 - 19" Radius Snap-Track® Section

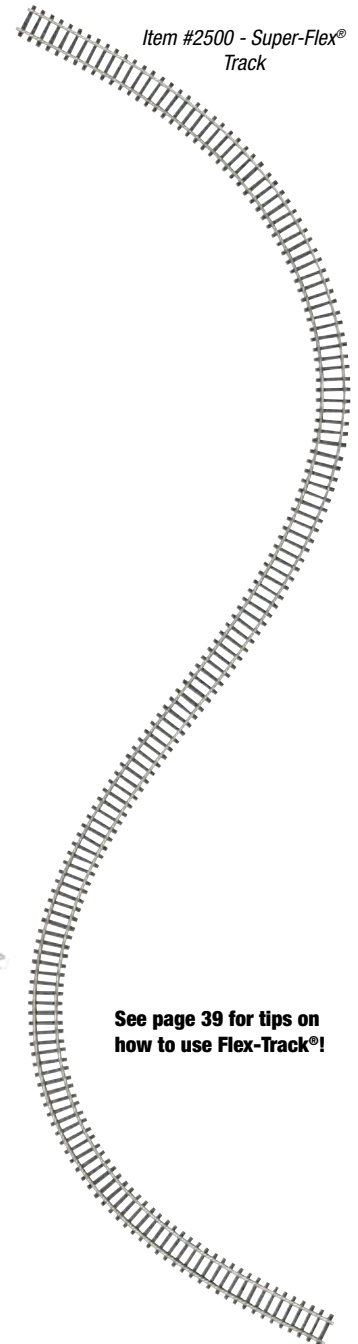

Item #2500 - Super-Flex®
Track

See page 39 for tips on
how to use Flex-Track®!

To order, please find a dealer near you at <http://locator.atlasrr.com>. For more ordering information and pricing, please see the price list inserted in this catalog.

HOBBY STORE LOCATOR: [HTTP://LOCATOR.ATLASRR.COM](http://locator.atlasrr.com)

N CODE 80 TRACK



Item #2532 - Rerailer



Item #2536 - Bumper

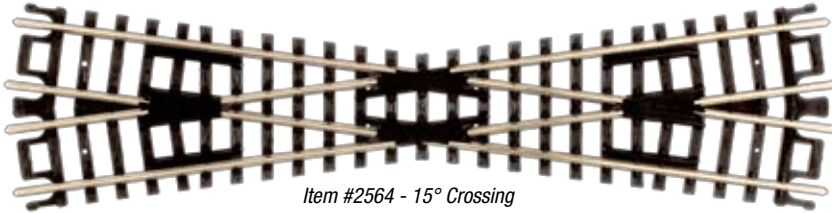

Item #2564 - 15° Crossing

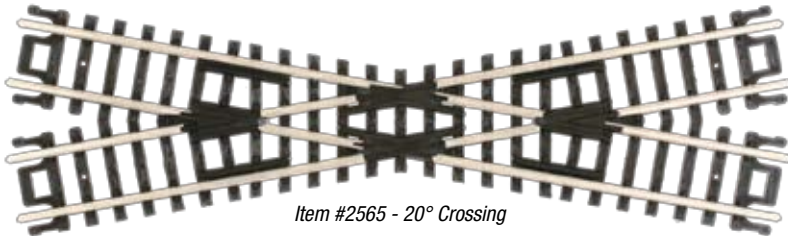

Item #2565 - 20° Crossing



Item #2566 - 30° Crossing

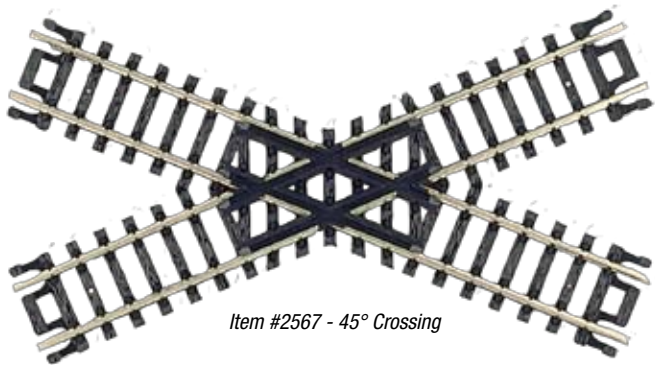

Item #2567 - 45° Crossing

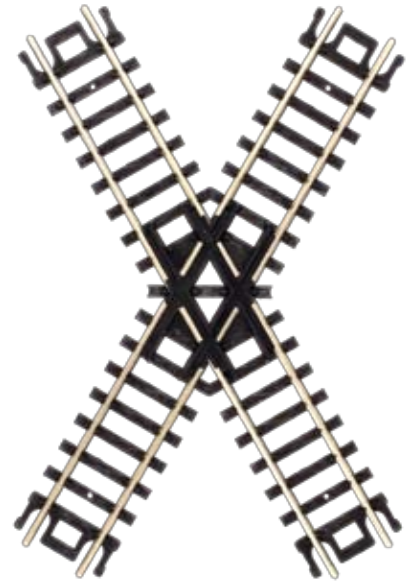

Item #2568 - 60° Crossing

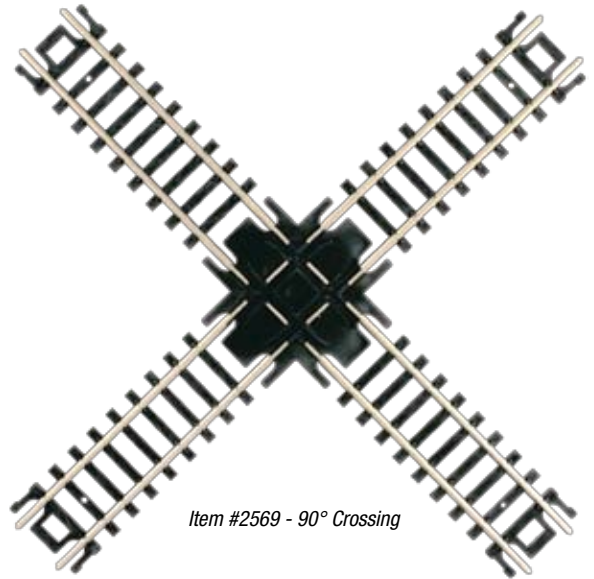

Item #2569 - 90° Crossing

To order, please find a dealer near you at <http://locator.atlasrr.com>. For more ordering information and pricing, please see the price list inserted in this catalog.

HOBBY STORE LOCATOR: [HTTP://LOCATOR.ATLASRR.COM](http://locator.atlasrr.com)

N CODE 80 TRACK

N STANDARD TURNOUTS

Our series of turnout make operating your layout a long lasting pleasure. More **RELIABLE** than ever, Atlas N turnouts feature:

- Refined and narrower flangeways at the frog and guard rails
- Positive mechanical attachment of points
- Better electrical conductivity
- Smaller switch machine for fit into tighter places
- Series of Custom-Line® Turnouts intended for use with Atlas Under-Table Switch Machines (#65 or #66) or ground throws

Code 80 Turnout Angles

- #4 (Item #2700, 2701, 2702, 2703, 2750, 2751)
Turnout Angle = 14° 15' (14.25°)
- #6 (Item #2704, 2705, 2706, 2707, 2752, 2753)
Turnout Angle = 9° 32' (9.53°)

N STANDARD TURNOUTS (REMOTE)

These turnouts have a remote control switch machine attached so you can wire the switch to be "thrown" (changing the direction of the rail), from your control panel rather than from the switch itself. Remote control turnouts include the #56 Switch Control Box and one piece of 19" radius track. *Caution: Do not hold button down for longer than one second.*

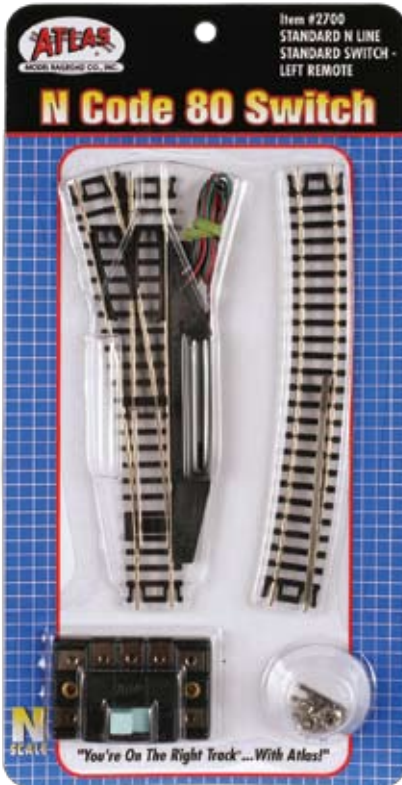

Item #2700 - Standard Remote Turnout, Left Hand
(Replaces a 5" straight)



Item #2701 - Standard Remote Turnout, Right Hand

N STANDARD TURNOUTS (MANUAL)

Manual turnouts can only be "thrown" (changing the direction of the rail) by flipping a lever on the switch by hand. These Standard N Scale manual turnouts can be easily converted to remote control with #2715 (left hand) and #2716 (right hand) switch machines (comes with one piece of 19" radius).



Item #2702 - Standard Manual Turnout, Left Hand



Item #2703 - Standard Manual Turnout, Right Hand

To order, please find a dealer near you at <http://locator.atlasrr.com>. For more ordering information and pricing, please see the price list inserted in this catalog.

HOBBY STORE LOCATOR: [HTTP://LOCATOR.ATLASRR.COM](http://locator.atlasrr.com)

N CODE 80 TRACK

N #6 TURNOUTS (REMOTE)

These turnout have a remote control switch machine attached so you can wire the switch to be "thrown" (changing the direction of the rail), from your control panel rather than from the switch itself. Remote control turnouts include the #56 Switch Control Box.

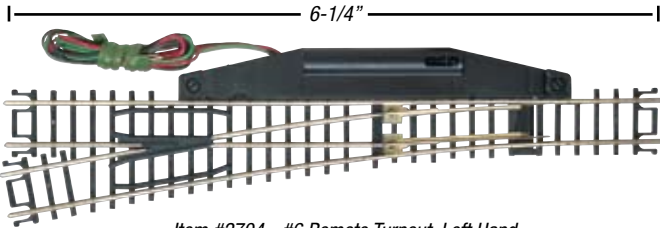

Item #2704 - #6 Remote Turnout, Left Hand

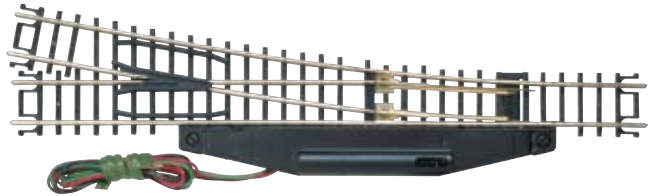

Item #2705 - #6 Remote Turnout, Right Hand

N #6 TURNOUTS (MANUAL)

Manual turnouts can only be "thrown" (changing the direction of the rail) by flipping a lever on the switch by hand. These #6 N Scale manual turnouts can be easily converted to remote control with #2715 (left hand) and #2716 (right hand) switch machines.



Item #2706 - #6 Manual Turnout, Left Hand



Item #2707 - #6 Manual Turnout, Right Hand

WHAT IS THE DIFFERENCE BETWEEN STANDARD AND #6 TURNOUTS?

The difference between the Standard turnout and #6 turnout is the angle at which the curved piece of track splits from the straight piece. The rails of the Standard turnouts split at a sharper angle than the #6 turnouts, creating a sharper curve. Therefore, Standard turnouts work better in smaller spaces.

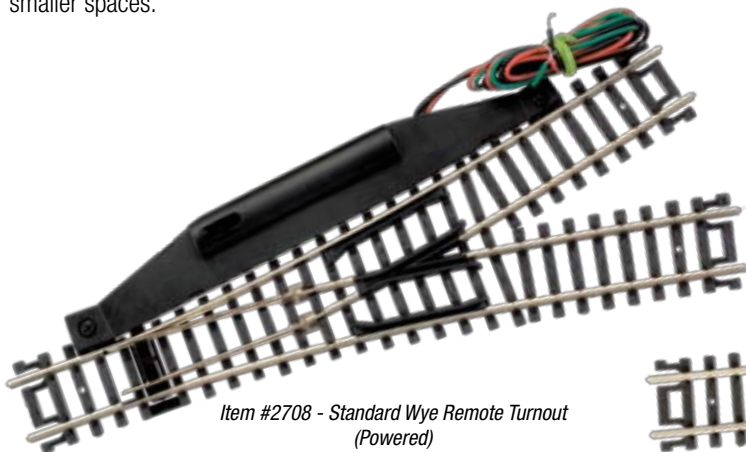

Item #2708 - Standard Wye Remote Turnout (Powered)



Item #2709 - Standard Wye Manual Turnout (Unpowered)

To order, please find a dealer near you at <http://locator.atlasrr.com>. For more ordering information and pricing, please see the price list inserted in this catalog.

HOBBY STORE LOCATOR: [HTTP://LOCATOR.ATLASRR.COM](http://locator.atlasrr.com)

N CODE 80 TRACK

• • • • • N CUSTOM N LINE® STANDARD TURNOUTS • • • • •

Custom N Line® turnout are designed for use with the Atlas Under-Table Switch Machine or an after-market ground throw. Unlike the other N Scale turnouts which have shortened ties to allow for switch machine attachment, Custom N Line® turnouts have full-length ties. A double-ended throw-bar allows you to place your under-table switch machine on either side of the turnout. Comes with one piece of 19" radius track.



Item #2750 - Custom N Line® Standard Turnout, Left Hand

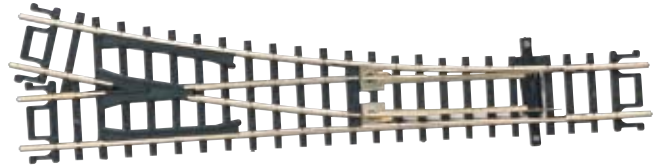

Item #2751 - Custom N Line® Standard Turnout, Right Hand



Item #2752- #6 Custom N Line® Turnout, Left Hand



Item #2753- #6 Custom N Line® Turnout, Right Hand

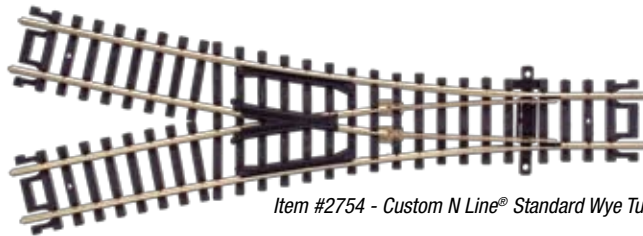

Item #2754 - Custom N Line® Standard Wye Turnout

• • • • • SWITCH MACHINES (REMOTE) • • • • •

Screw-on remote switch machines will quickly and easily convert Atlas Standard or #6 N turnouts to remote control. With a remote control turnout, you can wire the turnout to be "thrown" (changing the direction of the rail) from your control panel, rather than from the turnout itself.



Item #66 - Deluxe Under-Table Switch Machine

Includes a double-pole, double-throw relay with actuating mechanism. Can be used with most Atlas (and many other) HO and N scale switches. Note: Combined thickness must not exceed 1-5/8".



Item #65 - Under-Table Switch Machine

This switch machine positions nicely beneath your layout so you can throw your switches without it being seen. Can be used with most Atlas (and many other) HO and N scale switches. Note: Combined thickness must not exceed 1".



Item #2715 - Remote Switch Machine, Left Hand



Item #2716 - Remote Switch Machine, Right Hand

To order, please find a dealer near you at <http://locator.atlasrr.com>. For more ordering information and pricing, please see the price list inserted in this catalog.

HOBBY STORE LOCATOR: [HTTP://LOCATOR.ATLASRR.COM](http://locator.atlasrr.com)

N CODE 80 TRACK LAYOUTS

CHOOSING A LAYOUT

1. SELECTING YOUR LAYOUT

Each of the following layouts depicts a larger plan contained in an Atlas instruction book. The layouts in this catalog provide a basic overview of plans currently published by Atlas. After choosing a layout that fits your skill level, available space and budget, you'll find all the necessary information to construct it in the Atlas book listed. (Do not attempt to construct a layout based solely on the data in this catalog.) A product list is included with each layout in the appropriate Atlas instruction book.

2. OBTAIN YOUR LAYOUT BOOK

Each layout is detailed in one of the Atlas layout books. You will find the name and number of the book you'll need next to the sketch of your chosen layout. See page 7 for more details on Atlas layout books.

3. PURCHASE THE LAYOUT

Atlas products are sold worldwide in hobby shops, as well as on our online store. Developing a relationship with your local hobby shop can enhance and assist your model railroading experience. Utilizing the advanced Atlas International Dealer Locator on our website (below), you can view and download directions to hobby shops in your area. If you choose not to buy all components at once, you could divide the layout into independent sections, then expand your railroad at your discretion.

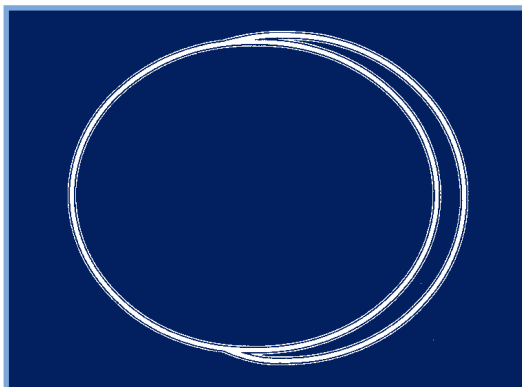

N-1 MINIMUM SIZE LOOP WITH PASSING TRACK

From Book #6: *Introduction to N Scale Model Railroading*

Minimum Table Size Required: 24" x 27"

N Scale Item #11001

Products Required: Straight sections, radius sections, turnouts, a crossing, insulated joiners and terminal joiners, necessary electrical components

The N1 is an introduction to the basic operation of all single-track railroading - the meeting of two trains at a "double-ended" siding long enough for one to pass the other. A nice thing about this layout is that it can be built on a small piece of plywood, so it only takes up a minimum amount of space.

N-2 LOOP WITH PASSING TRACK AND SIDINGS

From Book #6: *Introduction to N Scale Model Railroading*

Minimum Table Size Required: 24" x 40"

N Scale Item #11002

Products Required: Straight sections, radius sections, turnouts, a crossing, bumpers, insulated joiners and terminal joiners, necessary electrical components

On the N2, the passing track at the left end allows for a second more subtle maneuver when a single "local freight" is running on the line with cars to be delivered to both spur tracks. The locomotive can use the passing track to run around its train and get in position to shove cars into the spur which faces the "wrong way" for whichever direction it is traveling.

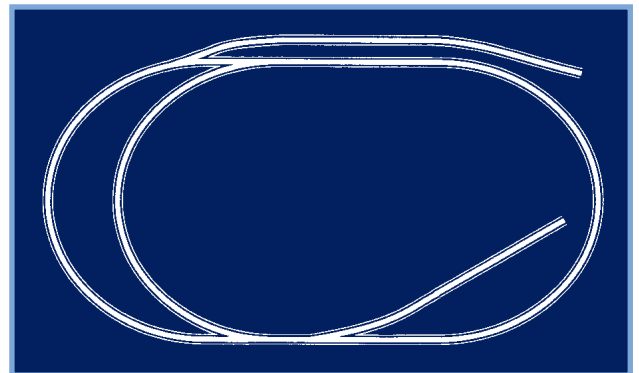

To order, please find a dealer near you at <http://locator.atlasrr.com>. For more ordering information and pricing, please see the price list inserted in this catalog.

HOBBY STORE LOCATOR: [HTTP://LOCATOR.ATLASRR.COM](http://locator.atlasrr.com)

N CODE 80 TRACK LAYOUTS

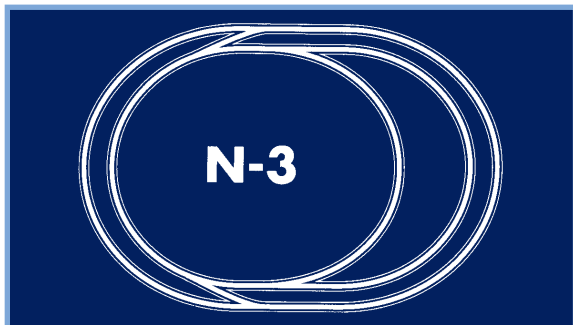

N-3 DOUBLE TRACK LOOP

From Book #6: *Introduction to N Scale Model Railroading*

N-3 Minimum Table Size Required: 24" x 27"

N Scale Item #11003

Products Required: Straight sections, radius sections, turnouts, a crossing, insulated joiners and terminal joiners, necessary electrical components

Layout N3 allows two trains to run continuously on the double-track main line. It also allows them to cross over to the other main and has a siding where a string of cars can be left for interchange.

N-4 DOUBLE TRACK LOOP

From Book #6: *Introduction to N Scale Model Railroading*

N-4 Minimum Table Size Required: 24" x 38"

N Scale Item #11004

Products Required: Straight sections, radius sections, turnouts, a crossing, bumpers, insulated joiners and terminal joiners, necessary electrical components

Layout N4 also features a double-track main line with cross-overs. For switching interest, this layout has a switchback siding.

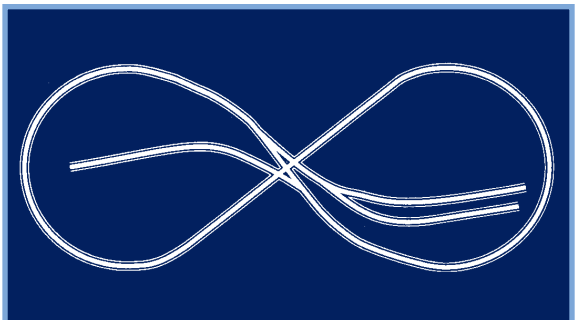

N-5 "UP AND OVER" FIGURE 8

From Book #6: *Introduction to N Scale Model Railroading*

Minimum Table Size Required: 22" x 53"

N Scale Item #11005

Products Required: Straight sections, radius sections, turnouts, a crossing, bumpers, insulated joiners and terminal joiners, necessary electrical components

Take an ordinary oval of track, twist one end and you have a figure 8 plan. The tracks can cross at grade or you can bridge one over the other using an Atlas Pier Set to achieve the required elevation.

N-6 EXPANDED DOUBLE TRACK LOOP

From Book #6: *Introduction to N Scale Model Railroading*

Minimum Table Size Required: 27" x 50"

N Scale Item #11006

Products Required: Straight sections, radius sections, turnouts, a crossing, bumpers, insulated joiners and terminal joiners, necessary electrical components

On the N6, two long trains can be run in opposite directions. In addition, two single ended spurs and the switchback siding allow for a wider variety of switching moves.

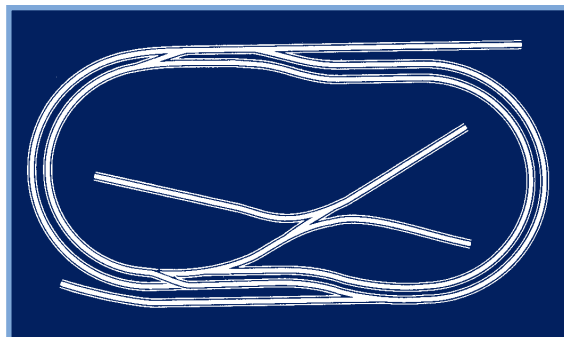

To order, please find a dealer near you at <http://locator.atlasrr.com>. For more ordering information and pricing, please see the price list inserted in this catalog.

HOBBY STORE LOCATOR: [HTTP://LOCATOR.ATLASRR.COM](http://locator.atlasrr.com)

N CODE 80 TRACK LAYOUTS

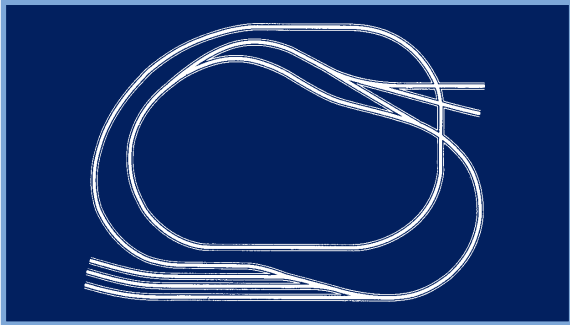

N-7 TWICE AROUND VIA "UP AND OVER"

From Book #6: *Introduction to N Scale Model Railroad*

Minimum Table Size Required: 32" x 45"

N Scale Item #11007

Products Required: Straight sections, radius sections, turnouts, a crossing, bumpers, insulated joiners and terminal joiners, necessary electrical components

If you enjoy watching a long train work its way up and down the grades of a long winding main line, the N7 is the layout for you. On this layout, yard tracks are available for breaking up and storing long trains, and a passing track with two industry spurs is available to provide additional operating diversions.

N-8 TWICE AROUND VIA TURNOUTS

From Book #6: *Introduction to N Scale Model Railroad*

Minimum Table Size Required: 30" x 60"

N Scale Item #11008

Products Required: Straight sections, radius sections, turnouts, a crossing, bumpers, insulated joiners and terminal joiners, necessary electrical components

The N8 is two simple loops connected together with turnouts. The two loops can be operated separately for two-train operation. In addition to the main line, there are two generous double-ended sidings. Another feature is the yard which will allow the engine of an incoming train to drop its cars and then escape on the adjacent track by using the two switches at the left end.

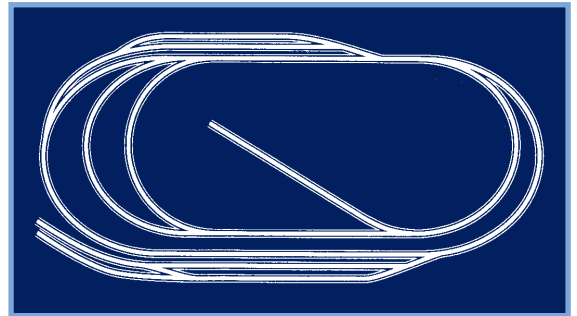

N-9 MULTIPLE TRACK ARRANGEMENT

From Book #6: *Introduction to N Scale Model Railroad*

Minimum Table Size Required: 27" x 60"

N Scale Item #11009

Products Required: Straight sections, radius sections, turnouts, a crossing, bumpers, insulated joiners and terminal joiners, necessary electrical components

The N9 is best known for its busy multiple track main lines. It contains a four-track yard, which is representative of a minor subdivision point and can store about 32 cars; some dropped off by freights and others brought in from the lineside industries by the sidings.

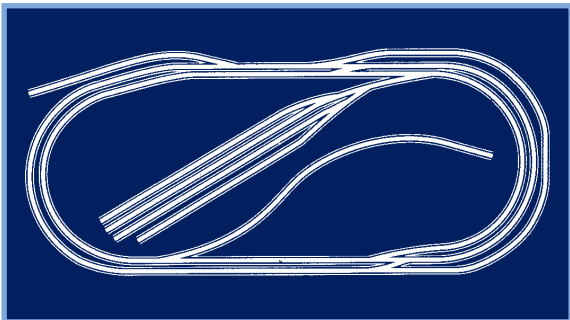

N-10 CLOCKWISE AND VICE VERSA

From Book #7: *Nine N Scale Railroads*

Minimum Table Size Required: 28" x 54"

N Scale Item #11010

Products Required: Straight sections, radius sections, turnouts, a crossing, bumpers, insulated joiners and terminal joiners, necessary electrical components

On the N10, two trains can keep moving. Its main line is a single track with two places where trains can meet or pass. One of the passing sidings parallels the main track, while the other provides an alternate figure 8 route.

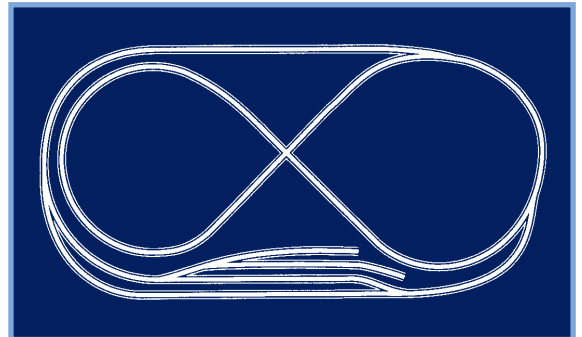

To order, please find a dealer near you at <http://locator.atlasrr.com>. For more ordering information and pricing, please see the price list inserted in this catalog.

HOBBY STORE LOCATOR: [HTTP://LOCATOR.ATLASRR.COM](http://locator.atlasrr.com)

N CODE 80 TRACK LAYOUTS

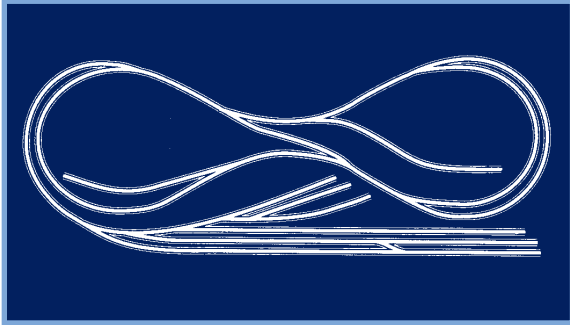

N-11 UNHINGED AND HORIZONTAL

From Book #7: *Nine N Scale Railroads*

Minimum Table Size Required: 30" x 78"

N Scale Item #11011

Products Required: Straight sections, radius sections, turnouts, a crossing, bumpers, insulated joiners and terminal joiners, necessary electrical components

The N11 has a unique feature: an "out and back" with a cut-off for continuous running. This railroad is also fun to operate. For example, the local freight which can leave the terminal first, has to keep the passenger schedule in mind and be sure to be in the passing track in time to avoid delaying the first-class train.

N-12 MINERAL RANGE ROUTE

From Book #7: *Nine N Scale Railroads*

Minimum Table Size Required: 48" x 96"

N Scale Item #11012

Products Required: Straight sections, radius sections, turnouts, a crossing, bumpers, insulated joiners and terminal joiners, necessary electrical components

This is a relatively big railroad area. The N12 enable you to exploit N scale's prime advantage: you can run long trains on it and still have enough room for plenty of scenery. On this layout, your trains can go from clockwise to counterclockwise travel and back again, without having to back up or be reshuffled at the terminal.

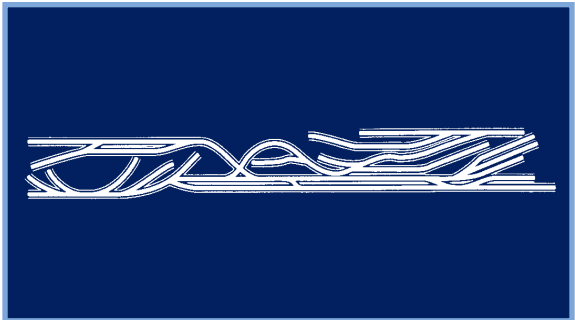
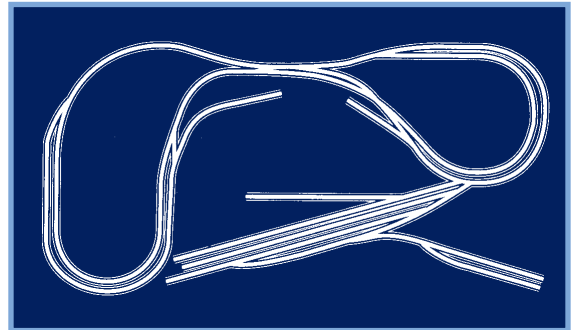

N-13 BADGER, BLOCKADE & BUFFALO

From Book #7: *Nine N Scale Railroads*

Minimum Table Size Required: 13.25" x 144"

N Scale Item #11013

Products Required: Straight sections, radius sections, turnouts, a crossing, bumpers, insulated joiners and terminal joiners, necessary electrical components

The N13 represents two separate mini-districts of a railroad. One, whose trackage is the Interchange District, swaps cars from all over the US. Its main task is to interchange traffic with the Industry District. The Industry District of the BB&B has one other connection with the outside world, but its principal purpose in life is to serve eleven other industries.

N-14 MONOPOLY AND OCTOPUS

From Book #7: *Nine N Scale Railroads*

Minimum Table Size Required: 48" x 48"

N Scale Item #11014

Products Required: Straight sections, radius sections, turnouts, a crossing, bumpers, insulated joiners and terminal joiners, necessary electrical components

Trains running on the flat simply aren't as interesting as those running over and under each other on a bridge. Since this layout features two passing tracks as well as two reversing tracks which allows you to have complete freedom of direction, it is a very exciting railroad.

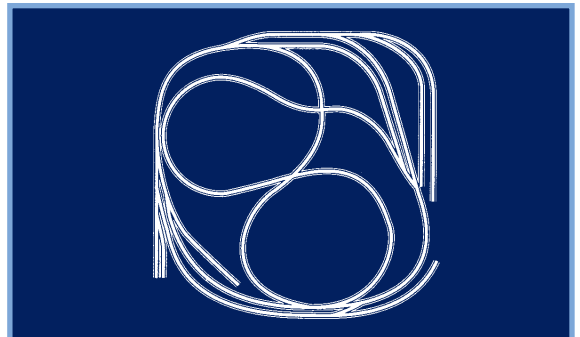

To order, please find a dealer near you at <http://locator.atlasrr.com>. For more ordering information and pricing, please see the price list inserted in this catalog.

HOBBY STORE LOCATOR: [HTTP://LOCATOR.ATLASRR.COM](http://locator.atlasrr.com)

N CODE 80 TRACK LAYOUTS

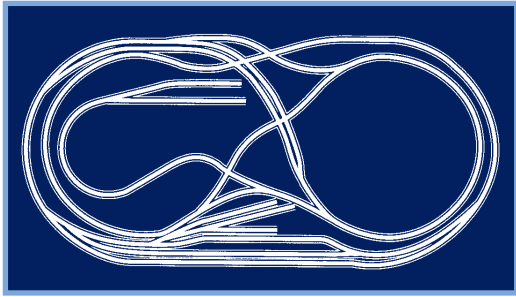

N-15 BROAD HORIZONS RAILROAD

From Book #7: *Nine N Scale Railroads*

Minimum Table Size Required: 48" x 120"

N Scale Item #11015

Products Required: Straight sections, radius sections, turnouts, a crossing, bumpers, insulated joiners and terminal joiners, necessary electrical components

The entire main line of the N15 has 19-inch radius curves. This means that trains of long cars look at home on it, and trains of short cars look even better. On the Broad Horizons you'll typically run long, main line trains. Since the branch has sharp turns which tend to give it a different flavor from the main line, there are many possibilities for additional industry tracks when you get around to it.

N-16 ATLANTIC LONGHAUL LINES

From Book #7: *Nine N Scale Railroads*

Minimum Table Size Required: 48" x 96"

N Scale Item #11016

Products Required: Straight sections, radius sections, turnouts, a crossing, bumpers, insulated joiners and terminal joiners, necessary electrical components

The N16 is a transitional railroad, mostly solid, flattop construction, but with a partial second deck reached via Atlas Piers on one track and an elevated plywood ramp on another. Its most notable innovation is its sit-in design. To achieve this, all you have to do is cut a trapezoidal notch out of the platform, big enough to sit in, and then use the plywood thus liberated as the second deck.

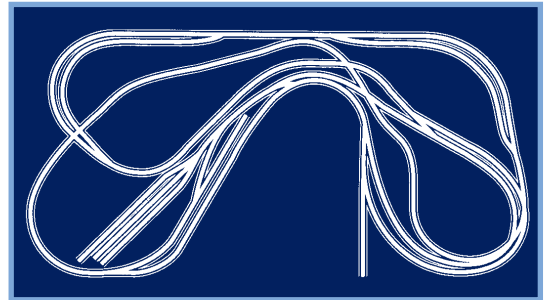

N-17 SCENIC AND RELAXED

From Book #7: *Nine N Scale Railroads*

Minimum Table Size Required: 36" x 72"

N Scale Item #11017

Products Required: Straight sections, radius sections, turnouts, a crossing, bumpers, insulated joiners and terminal joiners, necessary electrical components

With this layout you can get a lot of railroad and scenery in a small area due to the full "open grid" construction in which track boards are located on stilts only where road-bed is required and the rest of the space is completely open. Other good features of the N17 are a twice-around main line with two double-ended passing tracks allowing continuous operation of two trains on a single track.

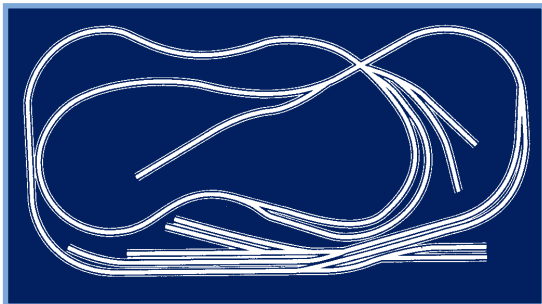

N-18 GULF SUMMIT LINES... SUSQUEHANNA VALLEY RAILWAY

From Book #7: *Nine N Scale Railroads*

Minimum Table Size Required: 48" x 74.25"

N Scale Item #11018

Products Required: Straight sections, radius sections, turnouts, a crossing, bumpers, insulated joiners and terminal joiners, necessary electrical components

In a 48 x 74 inch space, this layout boasts two separate railroads, both double-track; one an irregular oval and the other a figure 8. Also featured are two interconnecting tracks which ramp their way up from the Susquehanna Valley to the Gulf Summit.

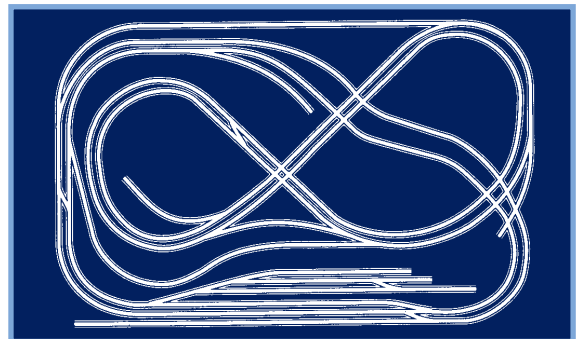

To order, please find a dealer near you at <http://locator.atlasrr.com>. For more ordering information and pricing, please see the price list inserted in this catalog.

HOBBY STORE LOCATOR: [HTTP://LOCATOR.ATLASRR.COM](http://locator.atlasrr.com)

N TRACK CLEANING CAR



Item #32555 - Maintenance of Way

N SCALE TRACK CLEANING CAR

Running your trains on rails that are grimy with dust, dirt and grit impedes performance and can harm your equipment. It is important to keep your track clean to protect your fleet and keep your trains running smoothly.

Each car includes one track cleaning car, three dry-type discs, three moist-type cleaning discs, vacuum fan disc (installed), disc changer tool, brush and sponge. The N Scale Track Cleaning Car is only available with Rapido couplers. (Cleaning Fluid not included. Modelers may use any commercially available track cleaner. Use as directed)



Item #32551 - Maintenance of Way



Item #32550 - Atlas - ATCX



Item #32554 - Maintenance of Way



Item #32552 - Cleaning Head Replacement Set



Item #32553 - Cleaning Disk Replacement Set

To order, please find a dealer near you at <http://locator.atlasrr.com>. For more ordering information and pricing, please see the price list inserted in this catalog.

HOBBY STORE LOCATOR: [HTTP://LOCATOR.ATLASRR.COM](http://locator.atlasrr.com)

N STRUCTURES & ACCESSORIES

N SCALE PRE-ASSEMBLED TRACKSIDE STRUCTURES

If time is a problem for you, get on board with N Scale pre-assembled structures! Offered in a variety of color schemes and styles, these structures will add prototypical realism to your layout. With no painting or gluing necessary, you can spend more time doing what you love - operating your trains!



Item #2845-1 - N Kate's Colonial Home
(Also Available in Olive/Green and Gold/Red)



Item #2852-1 - N Kim's Classic Home
(Also Available in Light Blue/Dark Blue/Beige/Black and Tan/Mustard/Yellow/Cream/Dark Green)

Lovely Ladies Home Series™

Modeled after popular catalog homes of the 1920s and molded in attractive colors, the Lovely Ladies Home Series™ from Atlas Model Railroad Company will be an asset to any layout.



Item #2847-2 - N Barb's Bungalow
(Also Available in Gray/Blue/Black and White/Green/Black)



Item #2849-3 - N Maywood Station
(Also Available in Gray/Maroon and Tan/Brown)

N SCALE TRACKSIDE STRUCTURE KITS & ACCESSORIES

Atlas has taken some of our popular HO structure kits and recreated them for N Scalers! Each kit is modeled after an actual prototype and is molded in appropriate colors so painting is not required. Assembly is easy using plastic compatible glue (not included).



Accessories that come with station and platform kits include a luggage cart with baggage and freight, a hand truck and a freight scale. Intricate exterior details of #2841 & #2842 include: an inlaid brick chimney, drainage pipes, oil tank, eave supports and realistically shingled roof.

Item #2841 & 2842 - N Passenger Station Kit
& N Station Platform Kit

To order, please find a dealer near you at <http://locator.atlasrr.com>. For more ordering information and pricing, please see the price list inserted in this catalog.

HOBBY STORE LOCATOR: [HTTP://LOCATOR.ATLASRR.COM](http://locator.atlasrr.com)

N STRUCTURES & ACCESSORIES



Item #2840 - N Signal Tower Kit



Item #2848 - N Maywood Station Kit



Item #2846 - N Barb's Bungalow Kit



Item #2851 - N Kim's Classic Home Kit



Item #2844 - N Kate's Colonial Home Kit



Item #2880 - N Kate's Colonial Micro-Plywood Garage Kit



Item #2860 - Barb's Bungalow Micro-Plywood Garage Kit



Item #2801 - N Telephone Poles

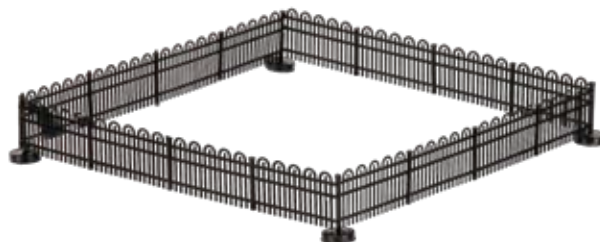

Item #2850 - N Hairpin Style Fence

To order, please find a dealer near you at <http://locator.atlasrr.com>. For more ordering information and pricing, please see the price list inserted in this catalog.

HOBBY STORE LOCATOR: [HTTP://LOCATOR.ATLASRR.COM](http://locator.atlasrr.com)

N STRUCTURES & ACCESSORIES

• • • • • N ROUNDHOUSE KIT & ACCESSORIES • • • • •

The basic 3-stall kit features brick detail, opening doors, stalls spaced at 15 degrees, an office, two styles of ventilators and modular construction. Molded in appropriate colors, it is expandable by additional 3-stall kits as desired. Each stall fits max. 8" locomotive over couplers. Designed to work with Atlas N Turntable #2790 and Atlas N Motor Drive #2791.



Item #2843 - N Roundhouse Kit (L 10-3/8" x W 11" x H 3")

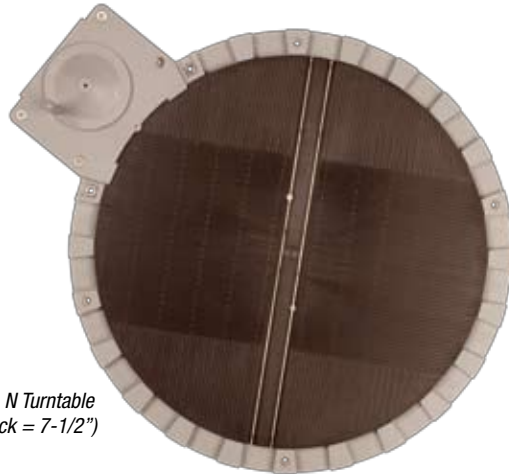

Item #2790 - N Turntable
(Turntable Deck = 7-1/2")



Back view



Item #2791 - N Turntable Motor Drive Unit
(Replacement belts sold separately, Item #9279112)



• • • • • N BRIDGES & ACCESSORIES • • • • •

All bridges are the same length as a standard 5" straight section. Snap them together atop the #2543 Bridge Piers in any number and arrangement for an impressively realistic multi-span structure!

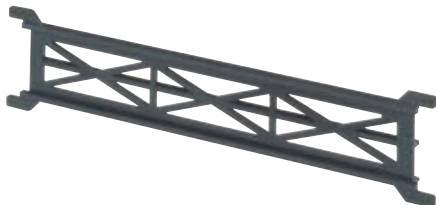

Item #2542 - Code 80 Straight Pier Girder



Item #2546 - Code 80 Warren Truss Bridge



Item #2547 - Code 80 Deck Truss Bridge



Item #2548 - Code 80 Plate Girder Bridge



Item #2543 - Code 80 Bridge Pier

To order, please find a dealer near you at <http://locator.atlasrr.com>. For more ordering information and pricing, please see the price list inserted in this catalog.

HOBBY STORE LOCATOR: [HTTP://LOCATOR.ATLASRR.COM](http://locator.atlasrr.com)

N STRUCTURES & ACCESSORIES



Item #2826 - Viaduct Kit

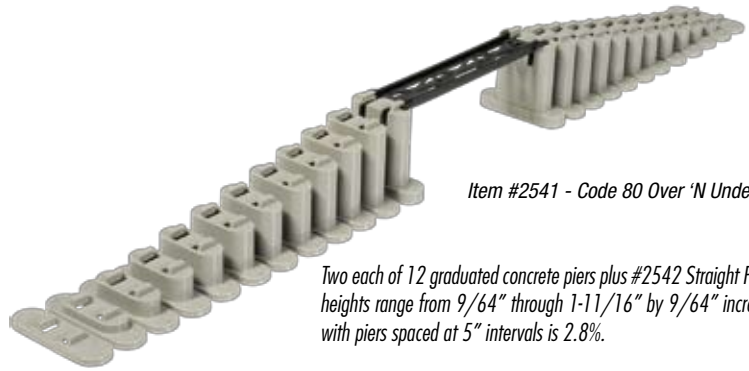

Item #2541 - Code 80 Over 'N Under Pier Set

Two each of 12 graduated concrete piers plus #2542 Straight Pier Girder. Pier heights range from 9/64" through 1-11/16" by 9/64" increments. Grade with piers spaced at 5" intervals is 2.8%.

• • • • • **N CODE 55 THROUGH PLATE GIRDER BRIDGE** • • • • •



Item #2080 - Single Track Kit



Item #2081 - Double Track Kit



Item #2082 - Add-On Kit

• • • • • **N CODE 80 DECORATED PLATE GIRDER BRIDGE** • • • • •

Based on common prototypes, Atlas' detailed N Code 80 Plate Girder Bridges are now decorated for well-known railroads across the country. These bridges are made with the same high-quality construction you've come to expect from Atlas.

*CSX licensed product



Item #2549 - Delaware & Hudson



Item #2550 - Erie



Item #2551 - New York Central*



Item #2552 - Rio Grande



Item #2553 - Santa Fe



Item #2554 - Union Pacific



Item #2555 - Great Northern



Item #2556 - Lackawanna



Item #2557 - New Haven



Item #2558 - Nickel Plate Road



Item #2559 - Pennsylvania



Item #2560 - Southern Pacific

To order, please find a dealer near you at <http://locator.atlasrr.com>. For more ordering information and pricing, please see the price list inserted in this catalog.

HOBBY STORE LOCATOR: [HTTP://LOCATOR.ATLASRR.COM](http://locator.atlasrr.com)

N, HO & O SCALE FLEX-TRACK™

ABOUT ATLAS SUPER-FLEX® TRACK

Our most popular product is renowned worldwide for its superiority, versatility and performance. Invented and patented by Atlas founder Stephen J. Schaffan Jr., this innovative, finely engineered precision track is the first choice of experts who demand the best.

Economical and easy to install, Super-Flex® Track enhances the realism of your layout. Unlike other curvable track which can "kink" when flexed, Atlas flexible track can be formed and re-formed to achieve the desired shape with ease. This unique track can be shaped to form curves of any radius, is ideal for spiral easement curves and is easily manipulated to help you make your layout visions reality. Atlas Super-Flex® Track is available in HO, N and O Scale versions.



(Item #502 - HO Code 83 Concrete Tie Super-Flex® Track)

Item #168 - HO Code 100 Super-Flex® Track - 36" Section

Item #178 - HO Code 100 "5 Pack" - 5 Pieces of 36" Super-Flex® Track

HOW TO USE SUPER-FLEX® TRACK

Super-Flex® Track has one stationary rail and one that slides, allowing it to bend easily. When bending the Flex-Track™ into the desired shape, you must keep in mind that the sliding rail should always be on the inside of the curve (closest to the center of your layout plan).

Once you are sure the sliding rail is facing the right way, tack the track loosely (in case you need to move it later) to your tabletop, then clip the excess rail, making it even with the stationary rail.

It can be cut easily to any needed length with any hobby saw, including Atlas' own Item #400 Modeler's Super Saw.

(Note: Some HO Code 83 Flex-Track™ has two rails that slide, which makes the track more flexible, but installation may differ.)

Item #500 - HO Code 83 Super-Flex® Track

Item #400 - Modeler's Super Saw

To order, please find a dealer near you at <http://locator.atlasrr.com>. For more ordering information and pricing, please see the price list inserted in this catalog.

PHONE: 908-687-0880 FAX: 908-851-2550 WWW.ATLASRR.COM WWW.ATLASO.COM

N, HO & O SCALE FLEX-TRACK™

ABOUT ATLAS O CUSTOM-FLEX® TRACK

Our patented Custom-Flex® Track enables you to duplicate prototypical trackwork where sectional track cannot be used. Available in 3-rail with simulated wood and concrete ties, and 2-rail with simulated wood ties, the track comes in 40" long sections.

The ability of our Custom-Flex® to bend without kinking (and return to straight profile easily) will allow you to reproduce realistic, spiral easement curves and other prototypical track arrangements. Since it has been engineered for easy installation, you will enjoy laying our Custom-Flex® on your next railroad.



(Item #7056 - 2-Rail
40" Flex-Track® with
Simulated Wood Ties)

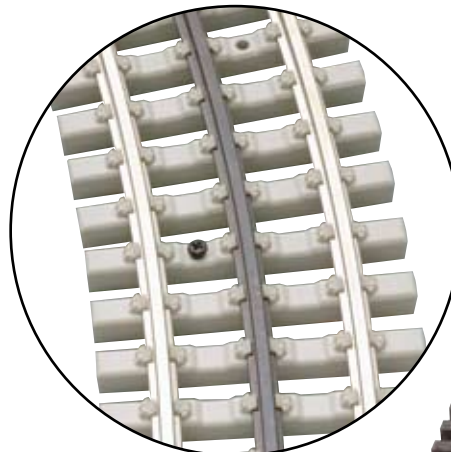

Item #6054 - 3-Rail
40" Custom-Flex® with Simulated
Concrete Ties

Atlas O also offers a finishing piece when using Custom-Flex® track or any track section that has been cut and a finished end is desired. The end section contains a snap lock and is available for the simulated wood tie and concrete sections. (See listing)

TIPS FOR LAYING CUSTOM-FLEX® TRACK

1. Draw a centerline on your table to serve as a guide for laying Custom-Flex®.
2. Connect one end of Custom-Flex® to your existing track, making sure the snap-locks are secure and the rails are flush with each other.
3. Remove the last three ties from the opposite end of the Custom-Flex® section. (The Atlas Snap-Saw, Item #400 works well for this.)
4. Bend the Custom-Flex® along the centerline you have drawn on the platform. Secure the track with Atlas O track screws, Item #6094 as you go along.
5. Trim the rails at the free end using a Dremel® tool with a cut-off disc. The rails should be cut evenly across.
6. Slide on the end snap you had removed previously. You now have a finished track end, which ensures the track will not kink at the junction between Custom-Flex® sections.
7. Repeat as often as necessary.

To order, please find a dealer near you at <http://locator.atlasrr.com>. For more ordering information and pricing, please see the price list inserted in this catalog.

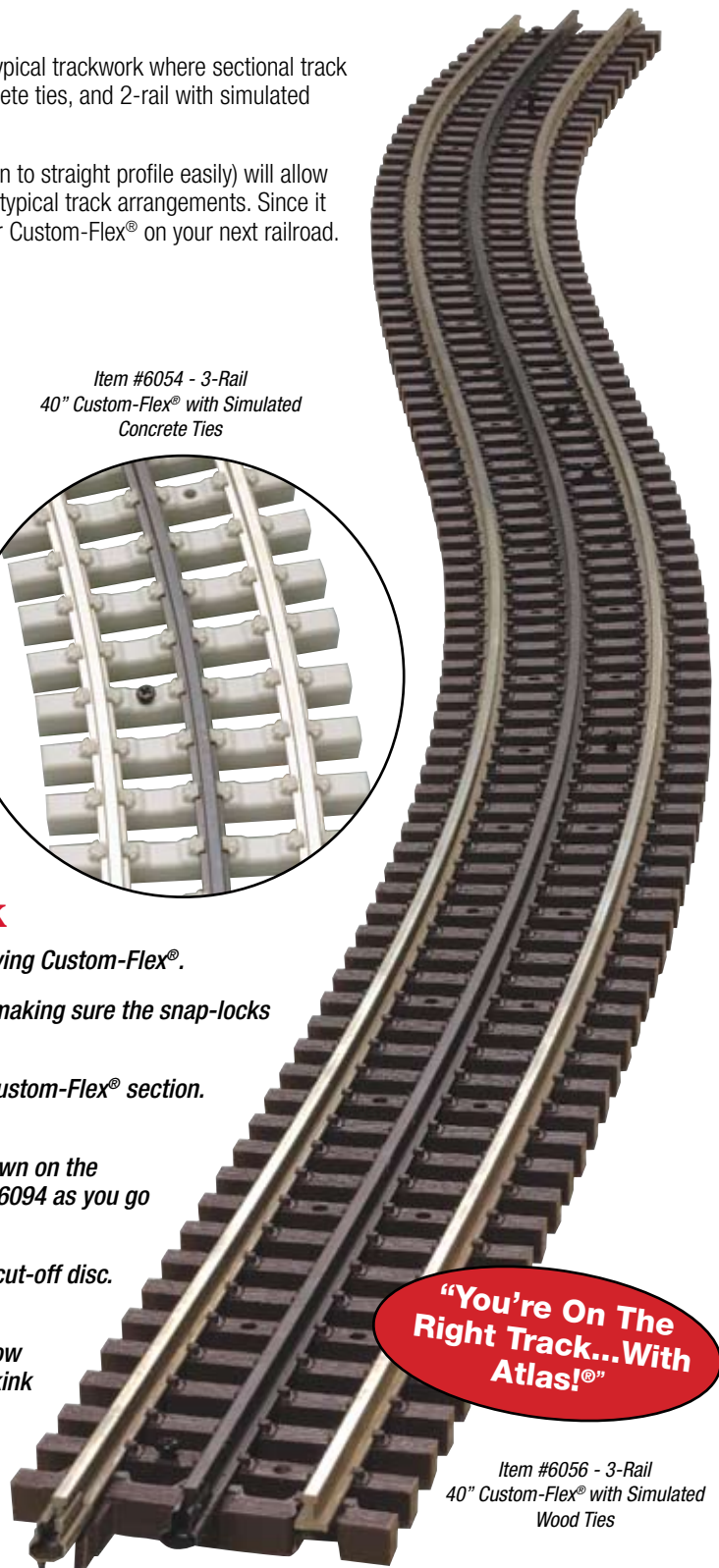

**"You're On The
Right Track...With
Atlas!®"**

Item #6056 - 3-Rail
40" Custom-Flex® with Simulated
Wood Ties

PHONE: 908-687-0880 FAX: 908-851-2550 WWW.ATLASRR.COM WWW.ATLASO.COM