

N HANDCRAFTED SCALE LIGHTING SYSTEM

1st QUARTER 2013 ARRIVAL

Light up your layout with brand new scale lighting from Atlas! Offered in both HO & N scales, these handcrafted street lamps make illuminating your layout quick and simple!

Road Name/Road Numbers	Item #	MSRP
New!		
Clock	60 000 062	26.95
Park Light ver. 1	60 000 063	25.95
Ball Light	60 000 064	25.95
Park Light ver. 2	60 000 065	25.95
Street Light	60 000 066	25.95
Highway Light ver. 1	60 000 067	26.95
Curved Light ver. 1	60 000 069	25.95
Curved Light ver.2	60 000 070	25.95

FEATURES:

- LED light source = longer life
- Brass construction
- Prototypical size for N scale model railroad layouts
- Quick fit base removes the need for gluing, nailing and screwing - Just "Drill and Drop"
- Lights come with quick connection plug in wire harness. Connects directly to power source. Resistors included.
- Light can be removed from mounting base and replaced with different style to change the look of any street or highway on your layout.

NEW!



Highway Light ver. 1



Park Light ver. 2



Clock

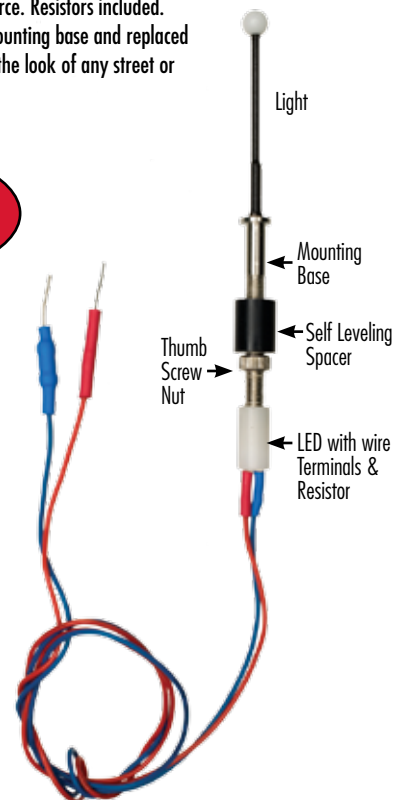

GP38-2 LOCOMOTIVE MASTER

JANUARY 2013 ANNOUNCEMENT

The Dash 2 locomotive series, unveiled by EMD in 1972, featured significant changes, such as a solid-state, modular electrical control system and improved engine components designed to increase traction and reduce exhaust emissions. A reliable work-horse, the GP38-2 remains one of the most successful locomotives ever built. Most are still in service today.

FEATURES:

- NCE Decoder (DCC models only)
- Painted safety rails
- Blackened metal wheels
- Factory-installed AccuMate® magnetic knuckle couplers
- Separately-applied coupler cut levers
- Golden-white LEDs
- Directional lighting
- Scale Speed™ motor

ADDITIONAL FEATURES:

- Non-Dynamic, Dynamic, and Extended Range Dynamic Brakes used where appropriate
- Pilot: With or without Snow Plow
- Low short hood versions available



Road Name/Road Numbers

- Undecorated w/o DB 47600
- Undecorated w/ DB 47601
- Undecorated w/ Extended Range DB 47602

Standard Item #

- 47600
- 47601
- 47602

DCC Item #

- _____
- _____
- _____

New Paint Schemes

Canadian Pacific 4508, 4510, 4511	40 000 605-40 000 607	40 000 628-40 000 630
Detroit, Toledo & Ironton 220, 223, 225	40 000 608-40 000 610	40 000 631-40 000 633
Elgin, Joliet & Eastern 700, 701, 702	40 000 611-40 000 613	40 000 634-40 000 636
Guilford (B&M) 205, 207, 211	40 000 614-40 000 616	40 000 637-40 000 639
Illinois Central Gulf 9609, 9616, 9636	40 000 617-40 000 619	40 000 640-40 000 642
Kansas City Southern 4017, 4018, 4020	40 000 620-40 000 622	40 000 643-40 000 645
Southern Pacific 4850, 4859, 4863	40 000 623-40 000 625	40 000 646-40 000 648
St. Lawrence & Hudson 7306, 7308	40 000 626-40 000 627	40 000 649-40 000 650

MSRP:

\$119.95

\$154.95



Canadian Pacific



Detroit, Toledo & Ironton

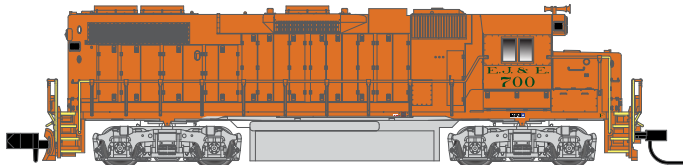

Elgin, Joliet & Eastern

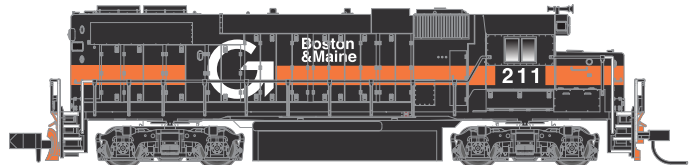

Guilford (B&M)

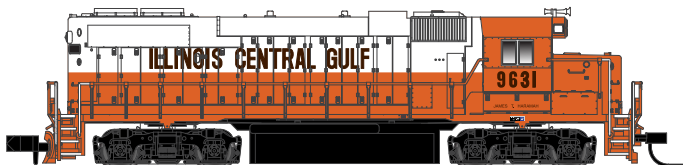

Illinois Central Gulf



Kansas City Southern

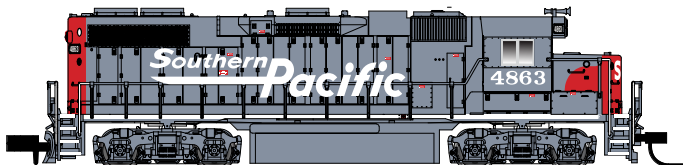

Southern Pacific



St. Lawrence & Hudson

MASTER U23B LOCOMOTIVE

FEBRUARY 2013 ANNOUNCEMENT

Powered by a V12 FDL prime mover, the 2250 h.p. U23B was GE's intermediate-sized four-axle road-switcher of the late 1960s through the mid 1970s. The U23B's direct competitor during this period was the very successful EMD GP38. In 10 years of production, from 1968 through 1977, a total of 481 units were produced, making this the second best seller of GE's "Universal Series" locomotives. The first units were delivered to the Delaware & Hudson in August and September 1968. CSX predecessors Chesapeake & Ohio and Louisville & Nashville had a combined fleet of 120 units, giving CSX one of the larger active fleets in later years. Penn Central, Santa Fe and Missouri Pacific also purchased sizeable fleets of U23Bs.

FEATURES:

- Operational low nose headlight (used where appropriate)
- Both DCC ready and DCC equipped versions
- NCE Decoder (DCC models only)
- Separate coupler cut lever
- Cab with 4 or 2 side windows (as appropriate per road name)
- Directional lighting
- Golden white LEDs
- Painted safety rails
- Blackened metal wheels
- Dual flywheel equipped 5-pole skewed armature motor with a low friction mechanism
- Factory-installed AccuMate® magnetic knuckle couplers!

*CSX Licensed Product (Models from previous runs shown)

Road Name/Road Numbers	Standard Item #	DCC Item #
Undecorated w/o Low Nose HL, AAR-B Trucks	45900	_____
Undecorated w/o Low Nose HL, FB-2 Trucks	45901	_____
Undecorated w/ Low Nose HL, FB-2 Trucks	45902	_____
New Road Numbers		
Chesie System* 2303, 2308, 2323	40 000 651-40 000 653	40 000 672-40 000 674
Delaware & Hudson 2307, 2309, 2304	40 000 654-40 000 656	40 000 675-40 000 677
Lehigh Valley 503, 507, 509	40 000 660-40 000 662	40 000 681-40 000 683
Santa Fe 6319, 6337, 6342	40 000 666-40 000 668	40 000 687-40 000 689
Western Pacific 2254, 2256, 2261	40 000 669-40 000 671	40 000 690-40 000 692
New Paint Schemes		
Family Lines (SBD)* 2712, 2736, 2745	40 000 657-40 000 659	40 000 678-40 000 680
Penn Eastern 2202, 2204, 2206	40 000 663-40 000 665	40 000 684-40 000 686
Undecorated MSRP:	TBA	TBA
MSRP:	TBA	TBA



Chesie System*



Delaware & Hudson



Santa Fe

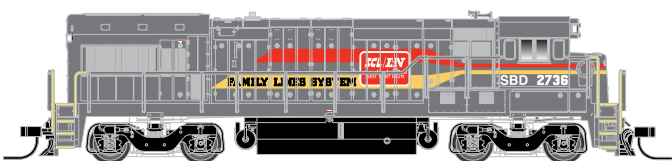

Family Lines (SBD)*



Lehigh Valley



Western Pacific

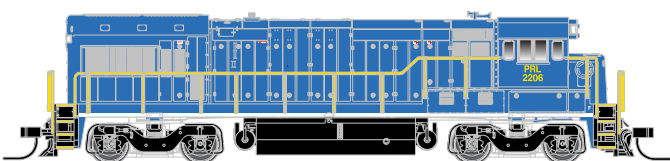

Penn Eastern

S-2 LOCOMOTIVE MASTER

MARCH 2013 ANNOUNCEMENT

Built by the American Locomotive Company (Alco) the low-hood S-2 was introduced in 1940 to replace Alco's earlier high-hood switchers. The 1000 horsepower S-2 was a turbocharged version of the S-1. There were 1,502 S-2s sold to North American Railroads. The versatility of the S-2s was evidenced by their service on mainline, shortline and industrial railroads.

FEATURES:

- Scaled from actual prototype measurements
- Option for horizontal or vertical radiator shutters
- Fine scale handrails
- Separately-applied coupler cut levers, air hoses, piping, etc.
- Directional LED lighting (includes cab rear headlight)
- Die-cast hood & chassis for improved pulling performance
- Digital-ready chassis
- Dual-flywheels for maximum performance at all speeds
- Factory-equipped with AccuMate® knuckle couplers
- Exceptional painting and printing



Road Name/Road Numbers

Item

New Model!

Undecorated	40 000 693
Boston & Maine 1260, 1261	40 000 694-40 000 695
Canadian Pacific 7013, 7061, 7091	40 000 696-40 000 698
Erie Lackawanna 521, 541, 542	40 000 699-40 000 701
Great Northern 1, 4	40 000 702-40 000 703
Pennsylvania 5659, 9106, 9108	40 000 704-40 000 706
Santa Fe 2350, 2357, 2367	40 000 707-40 000 709
Southern 2228, 2229	40 000 710-40 000 711

Undecorated MSRP:

TBA

MSRP:

TBA



Canadian Pacific

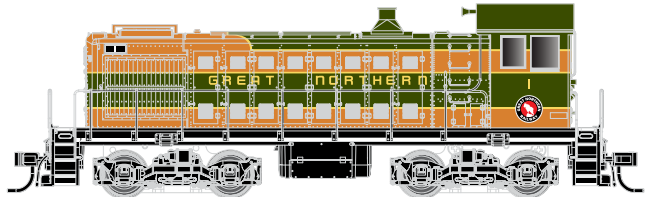

Great Northern

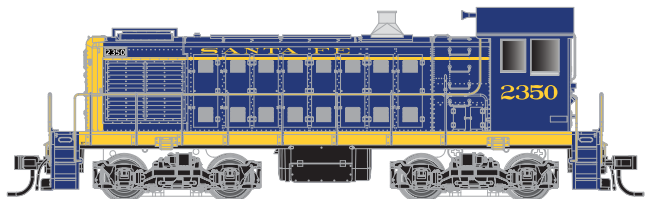

Santa Fe

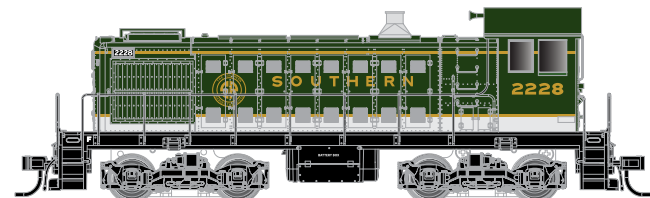

Southern

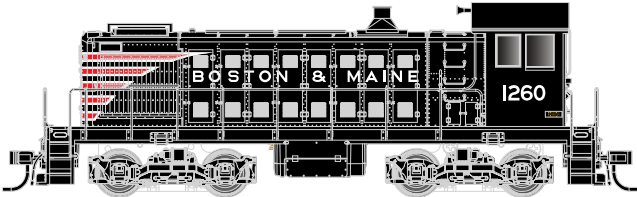

Boston & Maine



Erie Lackawanna

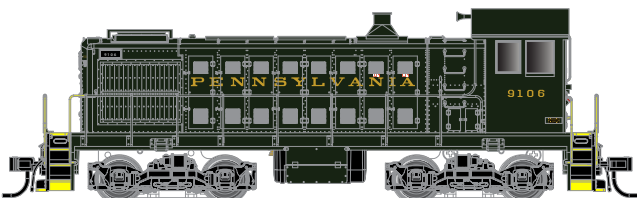

Pennsylvania

MASTER 40' WOOD REEFER

FEBRUARY 2013 ANNOUNCEMENT

This highly detailed model is based on the 40' wood refrigerator cars built by Pullman for the Northern Refrigerator Car Co. in 1930. With its rooftop ice hatches, USRA-style fish belly underframe and vertical brake shaft, it is representative of the thousands of similar cars that were built during the "Billboard" era of American railroads.

Road Name/Road Numbers	Item #
Undecorated	41400
New Paint Schemes	
Erie 62200, 62206	50 001 260-50 001 261
Horvitz Brothers 14403, 14404	50 001 262-50 001 263
Mexene 424, 426	50 001 264-50 001 265
Nucoa Products 40679, 40680	50 001 266-50 001 267
Phenix Cheese (URTX) 23237, 23238	50 001 268-50 001 269
St. Louis Refrigerator Company 4123, 4136	50 001 270-50 001 271
Undecorated MSRP:	TBA
MSRP:	TBA

FEATURES:

- Accurate painting and printing including door hinges, ladders, grab irons and end straps
- Opening roof hatches
- Realistic handle and latch detail
- Wood grain finish detail on carbody
- Ready-to-run
- 40-ton friction bearing trucks with AccuMate® couplers

(0 scale models shown)

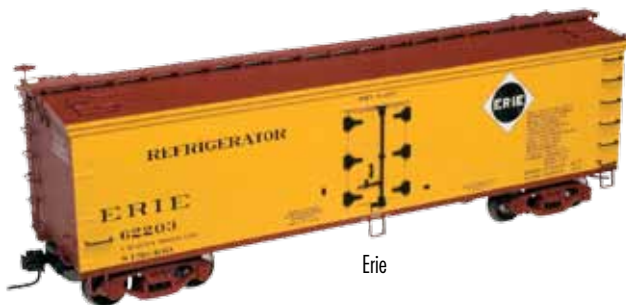

Erie



Horvitz Brothers



Mexene



Nucoa Products



Phenix Cheese



St. Louis Refrigerator Company

USRA SINGLE SHEATHED BOX CAR MASTER

MARCH 2013 ANNOUNCEMENT

Atlas' N Scale USRA Single Sheathed Box Car is modeled after the 50-ton outside braced boxcar designed by the United States Railway Administration during World War I. These cars quickly became a common sight on railroads from coast to coast.

FEATURES:

- Opening Door
- Ready-to-run
- Accurate painting and printing
- Highly detailed body
- Simulated wood or steel door as per the prototype
- Different rib ends (7-8 or 5-5-5) as per the prototype
- Undecorated cars come with both simulated wood or steel doors
- Andrews trucks
- AccuMate® couplers
- Brake detail

*CSX Licensed Product



Road Name/Road Numbers	Item #
Undecorated 7-8 Rib End	41700
Undecorated 5-5-5 Rib End	41701
New Paint Schemes	
Atlantic Coast Line 48514, 48558	50 001 246-50 001 247
Burlington Route (FW&D) 7223, 7231	50 001 248-50 001 249
Columbia, Newberry & Laurens 2502, 2508	50 001 250-50 001 251
Erie 92522, 92558	50 001 252-50 001 253
Milwaukee Road 701006, 701055	50 001 254-50 001 255
M-K-T 95271, 95307	50 001 256-50 001 257
Western Maryland* 26412, 26524	50 001 258-50 001 259
Undecorated MSRP:	TBA
MSRP:	TBA

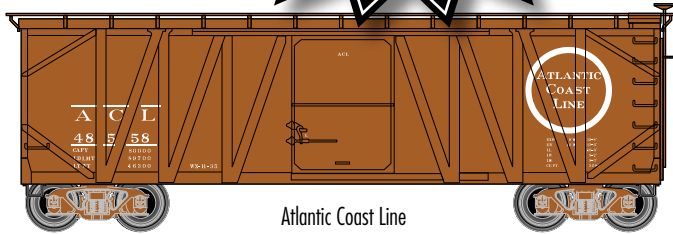

Atlantic Coast Line

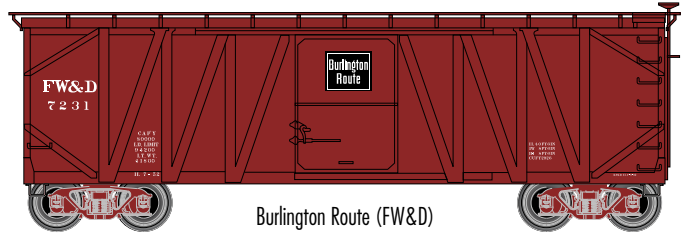

Burlington Route (FW&D)

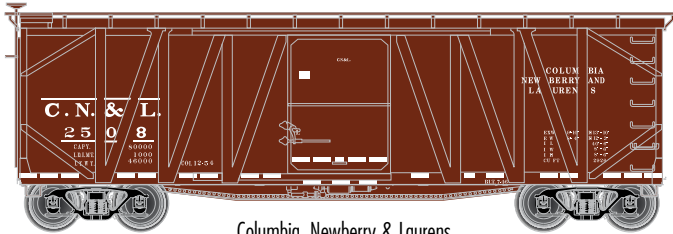

Columbia, Newberry & Laurens

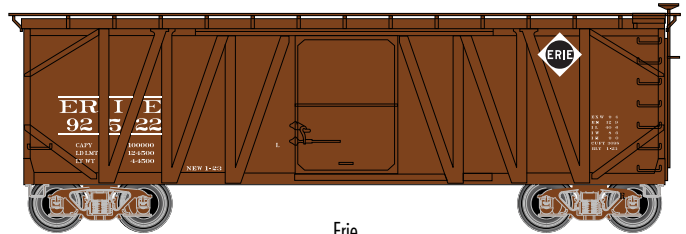

Erie

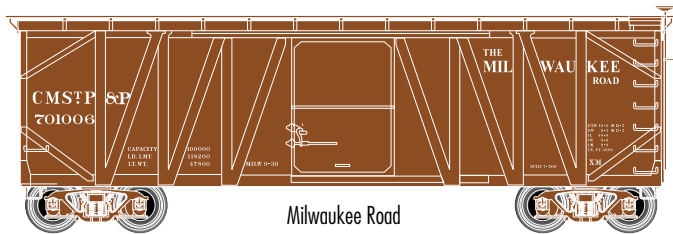

Milwaukee Road

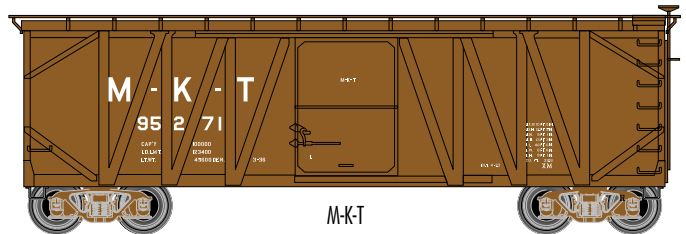

M-K-T

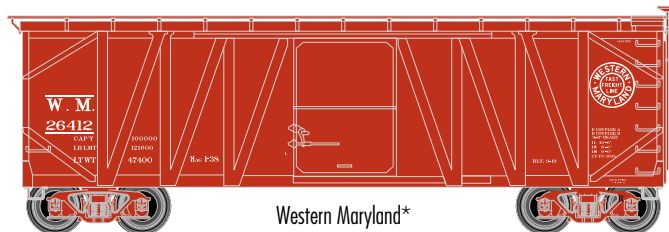

Western Maryland*

MASTER 50' PRECISION DESIGN BOX CAR

MARCH 2013 ANNOUNCEMENT

Built by ACF in the late 1960's and early 1970's, this ready-to-run model comes in both smooth side and rib side versions as per the prototype.

Road Name/Road Numbers	Item #
Undecorated	50 001 284
New Paint Schemes	
Atlantic and Western 8093, 8104	50 001 285-50 001 286
Canadian National 416133, 416137	50 001 287-50 001 288
Canadian National (GTW) 517966, 517987	50 001 289-50 001 290
Conrail 208092, 208098	50 001 291-50 001 292
New Road Numbers	
BNSF 722771, 722818	50 001 293-50 001 294
Chicago North Western 155189, 155193	50 001 295-50 001 296
Undecorated MSRP:	TBA
MSRP:	TBA

FEATURES:

- Prototypically detailed body with realistic ladders, brake wheel and see-through end crossover walkway
- Detailed die-cast metal underframe
- Separate brake system
- Air reservoir
- AccuMate® couplers
- 70-ton roller-bearing trucks
- Accurate painting and printing

(Models shown from previous runs)

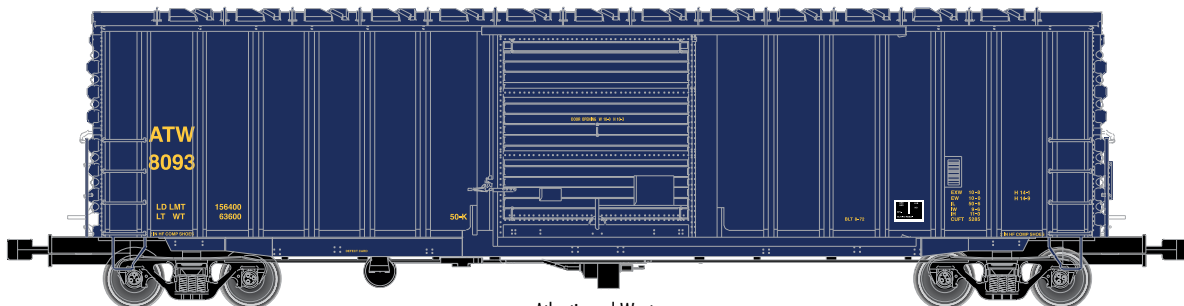

Atlantic and Western

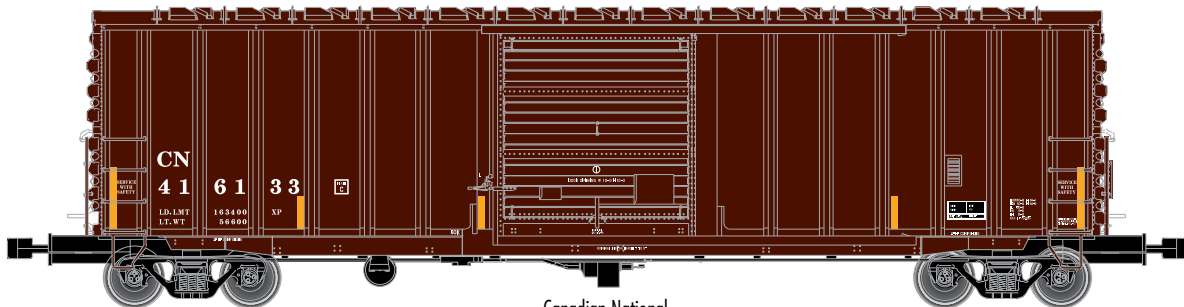

Canadian National

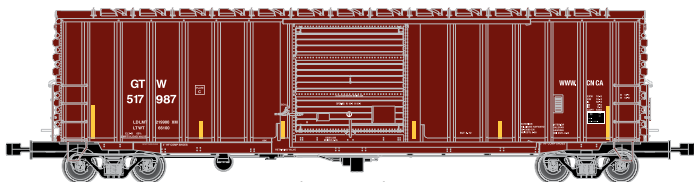

Canadian National (GTW)

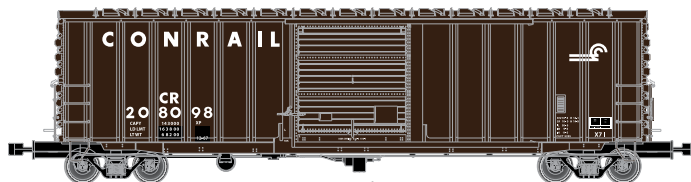

Conrail



BNSF



Chicago North Western

C&O CABOOSE TRAINMAN®

JANUARY 2013 ANNOUNCEMENT

The first all-steel cabooses built for the Chesapeake & Ohio Railroad were produced in 1937 by the Magor Car Corporation in Clifton, N.J. Magor, along with St. Louis Car Company and ACF, ultimately built a total of 350 cabooses for the C&O using a similar design. The last were produced in 1949. Through subsequent rebuilding and modernization, many remained in service through the end of regular caboose usage in the 1980s. Cabooses of a similar design were also built for Pere Marquette, Missouri Pacific and Chicago & Eastern Illinois.

FEATURES:

- Crisply molded body detail
- Weighted, detailed underframe
- Equipped with AccuMate® knuckle couplers
- Window glazing

*CSX Licensed Product (HO models shown)



Alaska Railroad



Boston & Maine



Delaware & Hudson



Grand Trunk Western



Norfolk Southern Railway



Providence & Worcester



Santa Fe



Chesapeake & Ohio* (yellow/blue)



Chesapeake & Ohio* (red/white)



Pere Marquette*

Road Name/Road Numbers	Item #
Undecorated	39800
New Paint Schemes	
Alaska Railroad 1068, 1077	50 001 203-50 001 204
Boston & Maine 462, 472	50 001 205-50 001 206
Delaware & Hudson 35706, 35872	50 001 207-50 001 208
Grand Trunk Western 114, 153	50 001 209-50 001 210
Norfolk Southern Railway 367, 371	50 001 211-50 001 212
Providence & Worcester 3001	50 001 213
Santa Fe 999952, 999961	50 001 214-50 001 215
New Road Numbers	
Chesapeake & Ohio* (yellow/blue) 90209, 90215	50 001 216-50 001 217
Chesapeake & Ohio* (red/white) 90255, 90290	50 001 218-50 001 219
Pere Marquette* 901, 905	50 001 220-50 001 221
Undecorated MSRP:	\$13.95
MSRP:	\$18.95

TRAINMAN® 2-BAY CENTERFLOW HOPPER

JANUARY 2013 ANNOUNCEMENT

Road Name/Road Numbers	Item #
Undecorated	50 001 297
New Road Numbers	
ACFX 44682, 44694	50 001 298-50 001 299
CSX* 227427, 227430	50 001 302-50 001 303
Southern Pacific 490242, 490373	50 001 306-50 001 307
New Paint Schemes	
Conrail 876322, 876399	50 001 300-50 001 301
GE Rail Car (NAHX) 35906, 35909	50 001 304-50 001 305
Winchester & Western 4101, 4107	50 001 308-50 001 309
Undecorated MSRP:	\$11.95
MSRP:	\$14.95

- FEATURES:
- AccuMate® couplers
 - Accurate painting and printing

*CSX Licensed Product

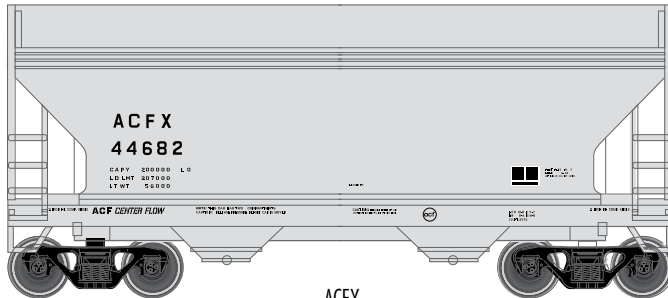

ACFX

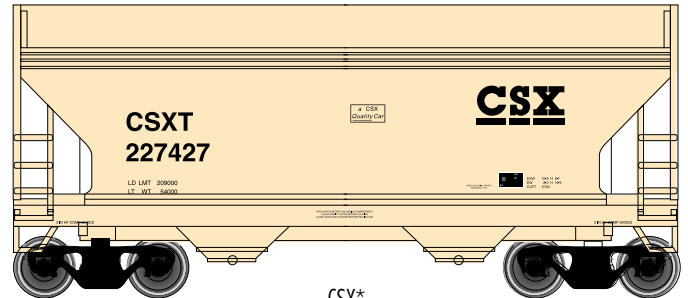

CSX*

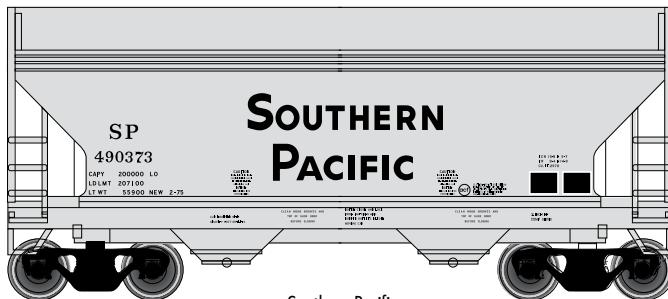

Southern Pacific



Conrail



GE Rail Car (NAHX)

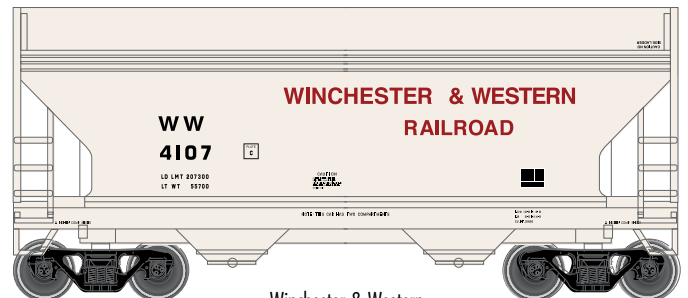

Winchester & Western

40' DOUBLE DOOR BOX CAR TRAINMAN®

FEBRUARY 2013 ANNOUNCEMENT

FEATURES:

- Newly tooled sides and ends
- Youngstown doors
- Improved Dreadnaught ends
- Crisp detailing
- Accurate painting and printing
- AccuMate® couplers

*CSX Licensed Product



Road Name/Road Numbers	Item #
Undecorated	38800
New Paint Schemes	
Canadian National 587166, 587267	50 001 272-50 001 273
Great Northern 38722, 38747	50 001 274-50 001 275
Manufacturers Railway 7501, 7505	50 001 276-50 001 277
Pennsylvania 67355, 67368	50 001 278-50 001 279
Santa Fe "Grand Canyon Line" 64279, 64283	50 001 280-50 001 281
Seaboard Coast Line* 822613, 822632	50 001 282-50 001 283
Undecorated MSRP:	TBA
MSRP:	TBA

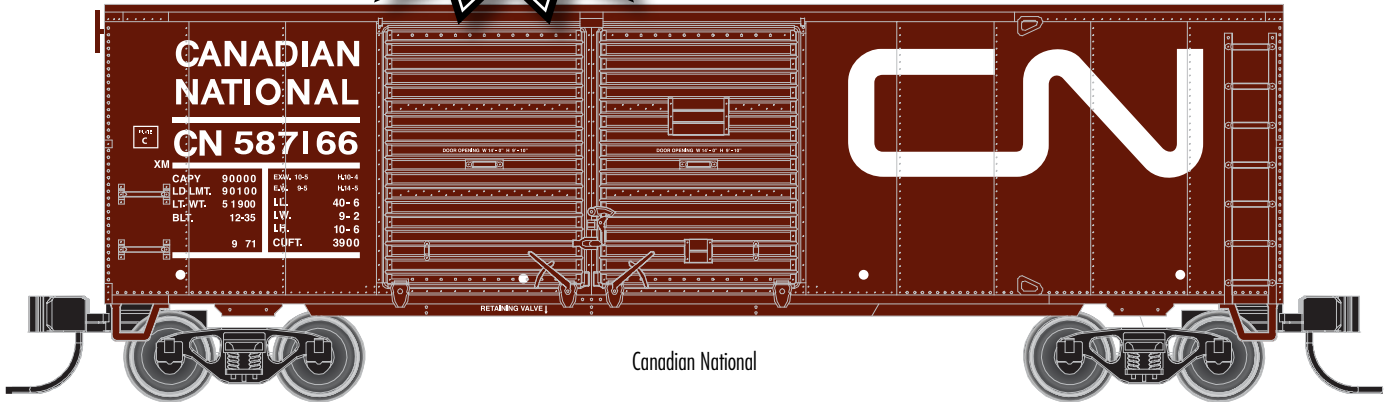

Canadian National

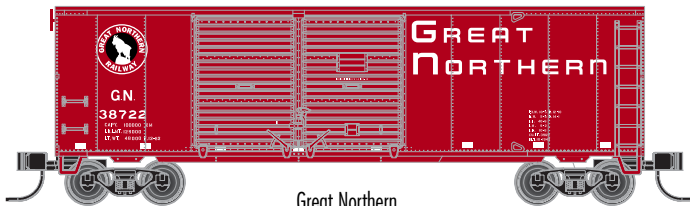

Great Northern



Manufacturers Railway

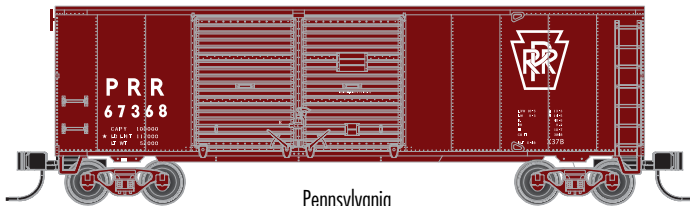

Pennsylvania



Santa Fe "Grand Canyon Line"



Seaboard Coast Line*

MASTER 4-4-0 LOCOMOTIVE

1st QUARTER 2013 ARRIVAL

Road Name/Road Numbers	Item #
New Model!	
Undecorated	40 000 464
Painted/Unlettered (Black/Gold)	40 000 465
Pennsylvania 1510	40 000 466
New Haven 848	40 000 467
Canadian Pacific Railway 49	40 000 468
Santa Fe 35	40 000 469
Standard MSRP:	\$119.95

FEATURES:

- Colorful decoration based on paint schemes from the late 1800s and early 1900s
- Smooth-running motor
- Operating headlight
- Separately-applied bell and handrails
- Factory-equipped with AccuMate® couplers
- Flared or straight stack as per the prototype

**SMOOTH
RUNNING
MOTOR!**



Pennsylvania



Painted/Unlettered



New Haven



Canadian Pacific Railway



Santa Fe

GP38/40 LOCOMOTIVE MASTER

1st QUARTER 2013 ARRIVAL

FEATURES:

- NCE Decoder (DCC models only)
- Directional lighting
- Walkway safety tread
- Blackened metal wheels
- Scale Speed™ motor
- Factory-equipped with AccuMate® knuckle couplers
- Dynamic brakes (as appropriate by railroad)
- Golden-white LEDs

+w/o dynamic brakes

Silent Running™ Drive is a registered trademark of NCE Corporation

**DIRECTIONAL
LIGHTING!**



Kansas City Southern



Ann Arbor



BNSF



BNSF "Patch"



HLCX



MKT



New Haven



Missouri Pacific



Providence & Worcester



Union Pacific



Western Pacific

Road Name/Road Numbers	Standard Item #	DCC Item #
N GP38 Low Nose Locomotive		
Undecorated w/o DB	49800	_____
Undecorated w/ DB	49801	_____
New Paint Schemes		
Ann Arbor 7771, 7791, 7802	40 000 364-40 000 366	40 000 389-40 000 390
BNSF 2043, 2044	40 000 367-40 000 368	40 000 391-40 000 392
BNSF "Patch" 2223, 2235	40 000 369-40 000 370	40 000 393-40 000 394
HLCX 3618, 3626	40 000 371-40 000 372	40 000 395-40 000 396
MKT+ 300, 302, 303	40 000 373-40 000 375	40 000 397-40 000 398
New Haven 253, 257	40 000 376-40 000 377	40 000 399-40 000 400
N GP40 Locomotive		
Undecorated w/o DB	48500	_____
Undecorated w/ DB	48501	_____
New Paint Schemes		
Kansas City Southern (GP-22ECO) 2810, 2813, 2820	40 000 378-40 000 380	40 000 401-40 000 402
Missouri Pacific+ 616, 631	40 000 381-40 000 382	40 000 403-40 000 404
Providence & Worcester 3001, 3002, 3003	40 000 383-40 000 385	40 000 405-40 000 406
Union Pacific 677, 683	40 000 386-40 000 387	40 000 407-40 000 408
Western Pacific 3532	40 000 388	40 000 409
MSRP:	\$119.95	\$154.95

MASTER SD60/60M LOCOMOTIVE

1st QUARTER 2013 ARRIVAL

Road Name/Road Numbers	Standard Item #	DCC Item #
Undecorated	49000	_____
New Paint Schemes		
CEFX Leasing 6012, 6016	49054-49055	49139-49140
CSX* (Blue/Yellow "YN-3") 8707, 8715, 8717	49056-49058	49141-49142
Indiana Railroad 6004, 6006, 6009	49059-49061	49143-49144
Norfolk Southern 6574, 6607, 6666	49062-49064	49145-49146
Panama Canal Railways 1870, 1871	49065-49066	49147-49148
Union Pacific 5949, 5985, 5991	49070-49072	49151-49152
New Road Numbers		
Soo Line 6013, 6025, 6039	49067-49069	49149-49150
Oakway Leasing 9000, 9042	49073-49074	49153-49154
Susquehanna 3808, 3810	49075-49076	49155-49156
Canadian Pacific 6240, 6241, 6250	49077-49079	49157-49158
MSRP:	\$129.95	\$169.95

FEATURES:

- Directional lighting
- Blackened wheels
- Slower speed motor for closer to scale speeds
- AccuMate® magnetic knuckle couplers
- Separate plow and winterization hatch that can be installed by the modeler
- Golden-White LEDs
- NCE Decoder (DCC models only)

*CSX Licensed Product

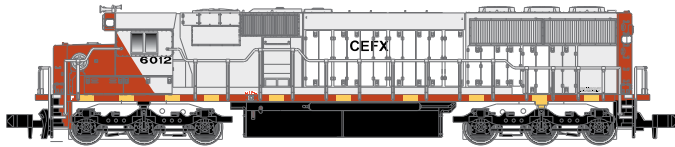

CEFX Leasing



CSX*



Indiana Railroad

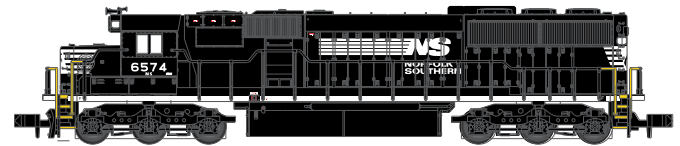

Norfolk Southern



Panama Canal Railways



Union Pacific



Soo Line

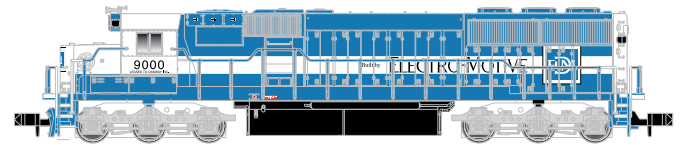

Oakway Leasing

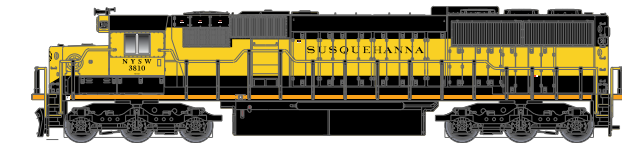

Susquehanna



Canadian Pacific

55 TON FISHBELLY COAL HOPPER MASTER

1st QUARTER 2013 ARRIVAL

FEATURES:

- Prototypical painting and lettering
- Die-cast underframe and slope sheets
- Friction-bearing trucks with AccuMate® operating knuckle couplers
- Plastic body with removable coal load
- Flat or peaked ends as per the prototype

*CSX Licensed Product

**FLAT OR
PEAKED
ENDS!**



Norfolk Southern



Norfolk & Western



Chesapeake & Ohio*



Lehigh Valley



Reading



Western Maryland*

Road Name/Road Numbers	Item #
N 55 Ton Fishbelly Hopper - Peaked End	
Undecorated - Peaked End	41000
New Road Numbers	
Norfolk Southern 9002, 9005, 9014	41334-41336
Norfolk & Western 38058, 38160, 38292	41337-41339
N 55 Ton Fishbelly Hopper - Flat End	
Undecorated - Flat End	41100
New Road Numbers	
Chesapeake & Ohio* 300400, 300432, 300449	41340-41342
Lehigh Valley 25052, 25099, 25200	41343-41345
Reading 80003, 80010, 80024	41346-41348
Western Maryland* 11870, 11899, 11917	41349-41351
Undecorated MSRP:	\$14.95
MSRP:	\$17.95

MASTER EVANS 52' 6" GONDOLA

1st QUARTER 2013 ARRIVAL

Road Name/Road Numbers	Item #
Undecorated	45500
New Paint Schemes	
Brandywine Valley RR 5526, 5573, 5580	50 000 543-50 000 545
Chicago & North Western 340001, 340202, 340153	50 000 546-50 000 548
Genesee and Wyoming 4126, 4128, 4133	50 000 549-50 000 551
Indiana Harbor Belt 46760, 46767, 46771	50 000 552-50 000 554
New Jersey Transit 9412, 9415	50 000 555-50 000 556
Jersey Central 9410	50 000 557
Missouri-Kansas-Texas 40227, 40417, 40478	50 000 558-50 000 560
U.S. Railway Equipment 40228, 40418, 40499	50 000 561-50 000 563
Wisconsin Central 6304, 6314, 6316	50 000 564-50 000 566
Undecorated MSRP:	\$13.95
MSRP:	\$18.95

FEATURES:

- True scale dimensions with accurate detail
- Separately applied end and side ladders
- 100 Ton roller-bearing trucks with offset shank AccuMate® couplers
- Die-cast under frame



Brandywine Valley RR



Chicago & North Western



Indiana Harbor Belt



New Jersey Transit



Jersey Central



Missouri-Kansas-Texas



U.S. Railway Equipment



Wisconsin Central



Genesee and Wyoming

23,500 GALLON TANK CAR MASTER

1st QUARTER 2013 ARRIVAL

FEATURES:

- Separately molded brake line plumbing
- Ultra-thin handrails
- Tank fittings and safety placards
- 100-ton roller-bearing trucks
- Brake wheel chain detail
- Accurate painting and lettering
- Factory-installed AccuMate® magnetic knuckle couplers



Road Name/Road Numbers

Road Name/Road Numbers	Item #
Undecorated	30700
New Paint Schemes	
Ennar Latex 89969, 89970, 89971, 89972	50 001 108-50 001 111
Exxon 405137, 405168, 405170, 405178	50 001 112-50 001 115
Invista 207320, 207323, 207330, 207377	50 001 116-50 001 119
J&J Railcar Leasing 198192, 198199, 198226, 198289	50 001 120-50 001 123
Southern Rail Associates 23931, 23935, 23942, 23947	50 001 124-50 001 127

Undecorated MSRP:

\$19.95

MSRP:

\$24.95

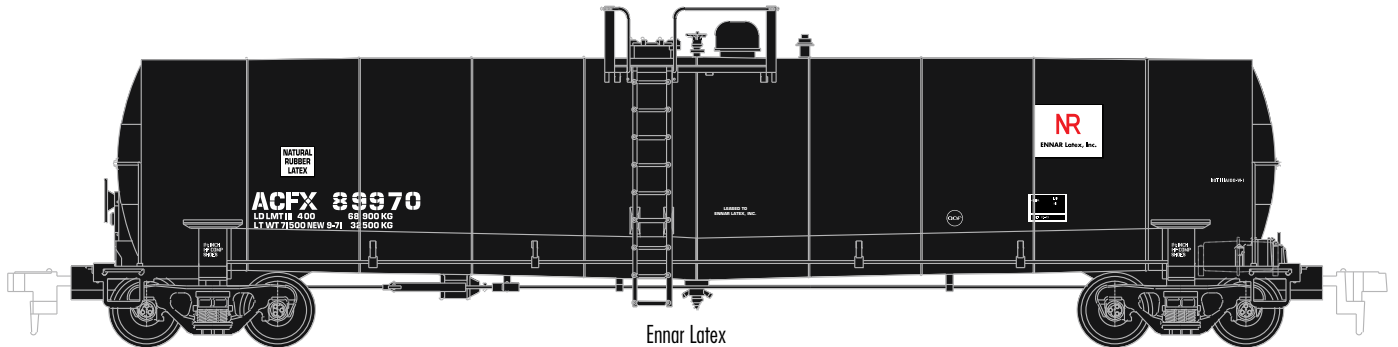

Ennar Latex

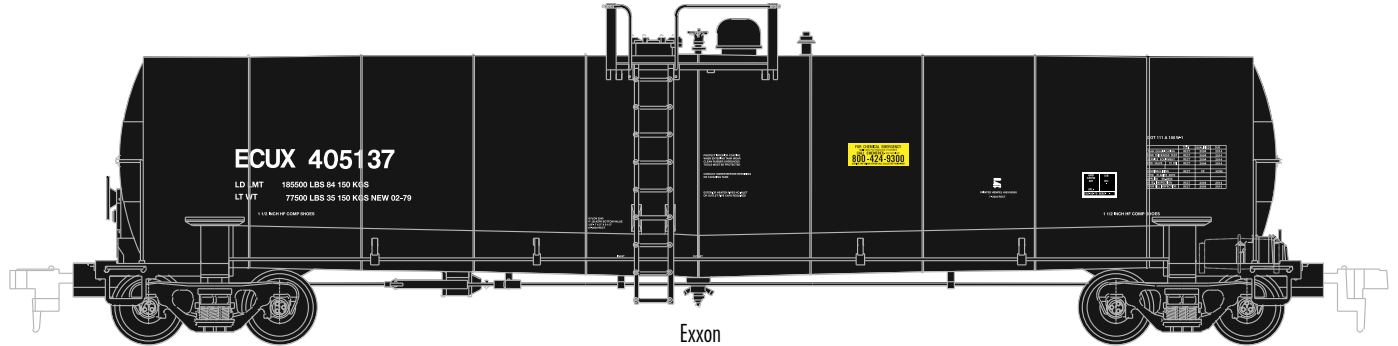

Exxon

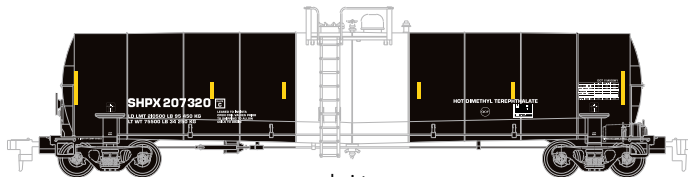

Invista

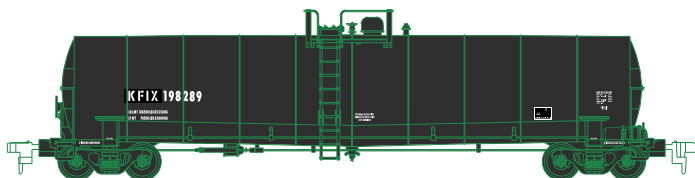

J&J Railcar Leasing

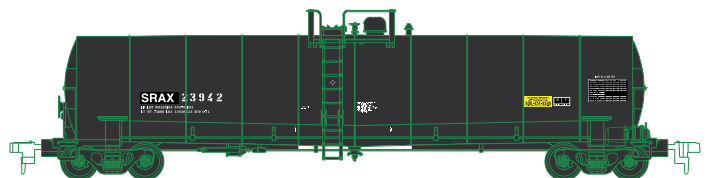

Southern Rail Associates

MASTER 17,600 GALLON CORN SYRUP TANK CAR

1st QUARTER 2013 ARRIVAL

Road Name/Road Numbers	Item #
Undecorated (ADM/MCP)	50 001 148
Undecorated (Cargill)	50 001 149
Undecorated (Corn Products)	50 001 150
New Paint Schemes	
ADM (No Logo) 15750, 15755, 15757, 15771	50 001 015-50 001 018
CIT Group 700013, 700030, 700033, 700037	50 001 019-50 001 022
Ontario Northland 5, 6	50 001 023-50 001 024
Tate & Lyle Staley 1508, 1512, 1729, 1853	50 001 025-50 001 028
VTG North America 17327, 17331, 17332, 17377	50 001 029-50 001 032
Undecorated MSRP:	\$17.95
MSRP:	\$25.95

FEATURES:

- Three separate styles of manway / platform / ladder arrangements (used as appropriate per road name)
- Separately applied brake rigging
- Separately applied manway "clamshell"-style cover (used when appropriate per road name)
- Highly detailed body with prototypical jacket seams
- Fine scale railings
- Accurate painting and printing
- Bottom outlet valve detail
- See-through top platform grating
- 100-Ton Roller Bearing Trucks
- Full stand-alone brake system details
- Stand-alone heater coil pipes
- AccuMate® couplers

STAND ALONE HEATER COIL PIPES!

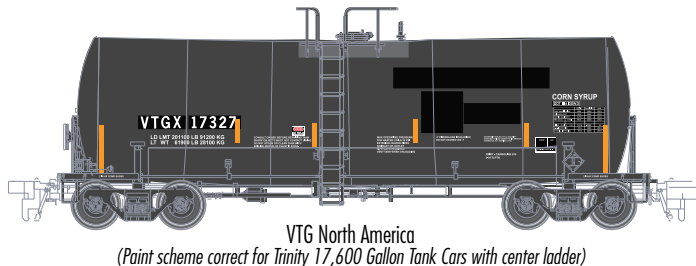
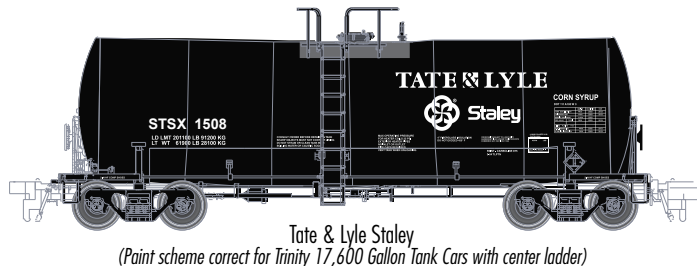
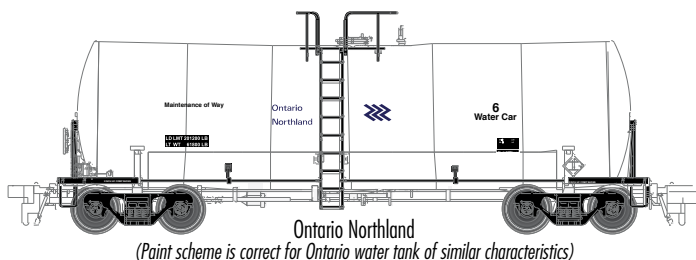
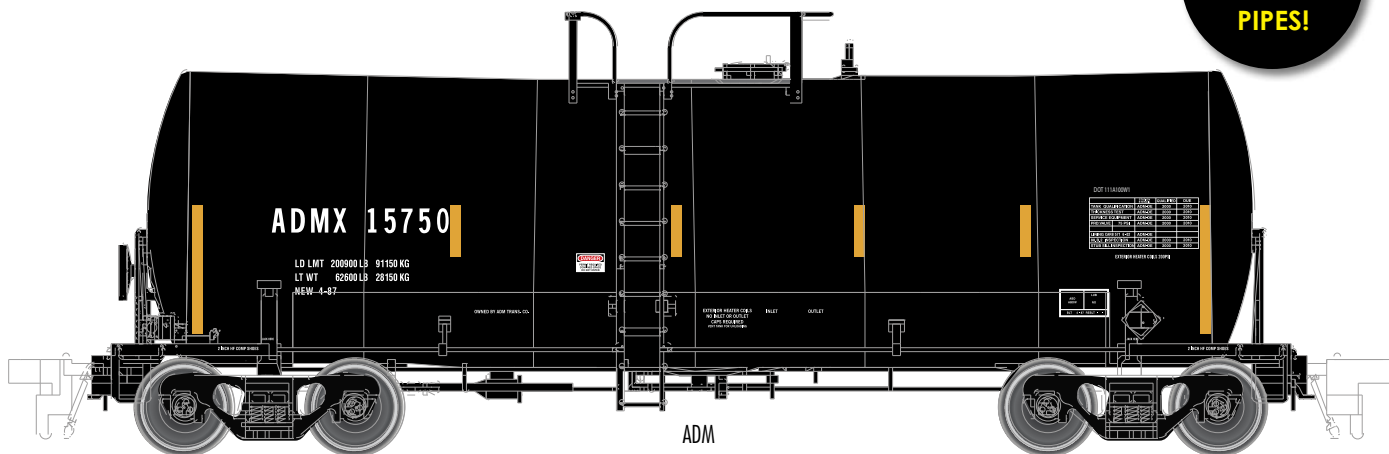

70 TON ORE CAR TRAINMAN®

1st QUARTER 2013 ARRIVAL

FEATURES:

- Ready-to-run
- AccuMate® couplers
- Accurate painting and printing
- Free-rolling trucks with brown plastic wheels
- Full rivet detail

**FULL
RIVET
DETAIL!**

Road Name/Road Numbers

Item #

Undecorated

3200

New Road Numbers

Burlington Northern 95940, 95942, 95955

40967-40969

Great Northern 95713, 95722, 95730

40970-40972

New Paint Schemes

Lake Superior & Ishpeming 1604, 1635, 1692

40973-40975

Missabe "Quad" 52725, 52790, 52806, 52812

40976-40979

Missabe "Safety First" Logo 28900, 28921, 28942

40980-40982

Union Pacific 26066, 26070, 26074

40983-40985

Undecorated MSRP:

\$10.95

MSRP:

\$13.95



Burlington Northern



Great Northern



Lake Superior & Ishpeming



Missabe "Quad"



Union Pacific



Missabe "Safety First"

TRAINMAN® 40' PLUG DOOR BOX CAR

1st QUARTER 2013 ARRIVAL

Road Name/Road Numbers	Item #
Undecorated	3300
New Paint Schemes	
Dairy Shippers Despatch 2023, 2033	50 001 084-50 001 085
American Colloid – Bicentennial 7290, 7292	50 001 086-50 001 087
Jersey Central 1438, 1499	50 001 088-50 001 089
Northern Pacific 98513, 98516	50 001 090-50 001 091
Canadian National 290474, 290479	50 001 092-50 001 093
Chicago & North Western 88300, 88302	50 001 094-50 001 095
Undecorated MSRP:	\$11.95
MSRP:	\$14.95

FEATURES:

- Prototypical painting and lettering
- AccuMate® couplers
- Roller-bearing or friction-bearing trucks where appropriate
- And more!



Dairy Shippers Despatch



American Colloid – Bicentennial



Northern Pacific



Canadian National



Chicago & North Western



Jersey Central

50' SINGLE DOOR BOX CAR TRAINMAN®

1st QUARTER 2013 ARRIVAL

FEATURES:

- Diagonal panel roof
- Improved Dreadnaught ends
- 9' Youngstown Door
- 50-Ton friction-bearing trucks with Accumate® couplers
- Crisp painting and printing



Road Name/Road Numbers	Item #
Undecorated	38900
New Paint Schemes	
Santa Fe 11321, 11313	50 001 096-50 001 097
Erie Lackawanna 65273, 65270	50 001 098-50 001 099
Penn Central 151805, 151811	50 001 100-50 001 101
M-K-T 99200, 99109	50 001 102-50 001 103
Nacionales de Mexico 79947, 79952	50 001 104-50 001 105
Canadian National 794203, 794210	50 001 106-50 001 107
Undecorated MSRP:	\$12.95
MSRP:	\$17.95



Santa Fe



Erie Lackawanna



Penn Central



M-K-T



Nacionales de Mexico



Canadian National

TRAINMAN PLUS® 85' TRASH FLAT CAR

1st QUARTER 2013 ARRIVAL

Road Name/Road Numbers	Item #
Undecorated	50 001 054
New Paint Schemes	
CIT Group 107000, 107012, 107036	50 001 055-50 001 057
Canadian National 638080, 638100, 638112	50 001 058-50 001 060
Canadian Pacific 520874, 520880, 520886	50 001 061-50 001 063
Florida East Coast 37111, 37148, 37190	50 001 064-50 001 066
New Road Numbers	
Allied Waste 20195, 20202, 20477	50 001 067-50 001 069
ECDC Environmental 93196, 93199, 93211	50 001 070-50 001 072
East Carbon-DSEX 7119, 7120, 7138	50 001 073-50 001 075
USA Waste 20260, 20297, 20302	50 001 076-50 001 078
Undecorated MSRP:	\$19.95
MSRP:	\$24.95

FEATURES:

- Open deck design
- True scale dimensions with accurate details
- Weighted, detailed underframes
- 100-ton trucks equipped with free-rolling metal wheels
- Accurate painting and printing



Perfect for use with Atlas' 20' MSW Trash Containers – found on page 45 of this catalog. (Previous run models shown)



CIT Group



Canadian National



Canadian Pacific



Florida East Coast



Allied Waste



ECDC Environmental



East Carbon-DSEX



USA Waste

MSW 20' TRASH CONTAINER TRAINMAN®

1st QUARTER 2013 ARRIVAL

FEATURES:

- Mounting pegs for 85' Trash Flat
- See-through forklift pockets
- Fire port on one side
- Prototypical paint schemes
- Molded chain detail

Perfect for use with our 85' Trash Flat Car featured on page 44 of this catalog!

For more information on trash containers, see the book *Railborne Trash and Waste Containers of New Jersey* by David Casdorph, available from Atlas. www.atlasrr.com/books/dc-trashcontainer.htm

Each set contains four assorted road numbers per road name.

Road Name/Road Numbers

Item #

New Paint Schemes

AWIU Set #2 (Red Stripe)	50 001 079
ECCU Set #1	50 001 081

New Road Numbers

DSEU Set #2	50 001 080
LWT Set #2	50 001 082
USWX Set #2	50 001 083

MSRP: \$19.95

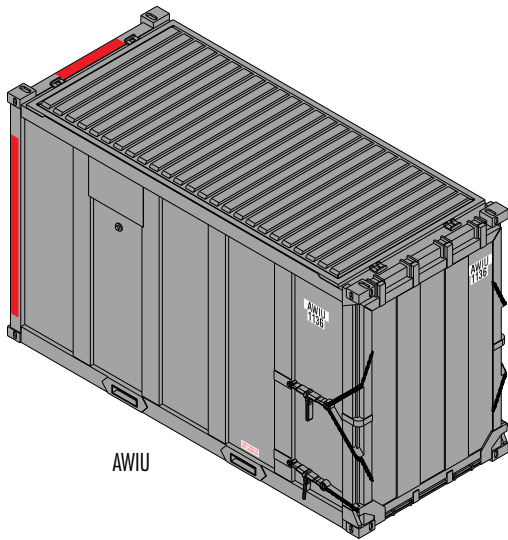

AWIU

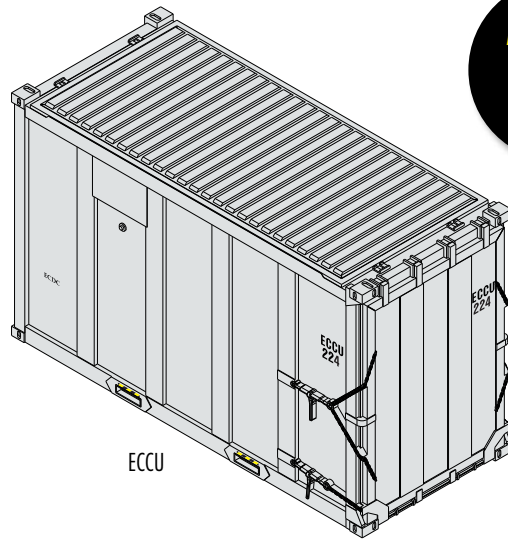

ECCU

MOLDED CHAIN DETAIL!



LWT



DSEU



USWX

TRAINMAN® THRALL 4750 COVERED HOPPER

1st QUARTER 2013 ARRIVAL

Road Name/Road Numbers	Item #
Undecorated	50 000 027
New Paint Schemes	
First Union Rail (Full Repaint) 828020, 828022, 828028, 828038	50 001 128-50 001 131
Illinois Grain 60155, 60158, 60188, 60195	50 001 132-50 001 135
Scoular 45275, 45282, 45290, 45294	50 001 136-50 001 139
SSAM 87649, 87674, 87688, 87689	50 001 140-50 001 143
Undecorated MSRP:	\$14.95
MSRP:	\$17.95

FEATURES:

- Weighted body
- Equipped with AccuMate® Knuckle Couplers
- Accurate painting and lettering

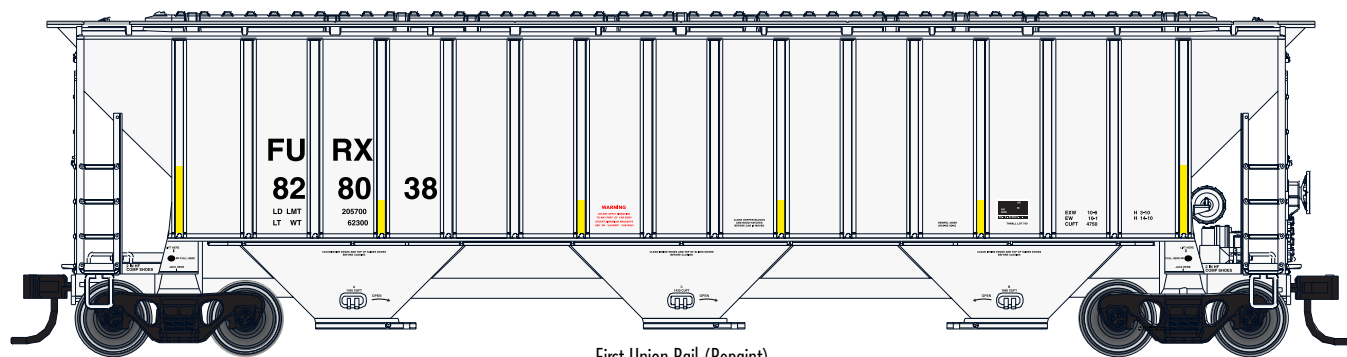

First Union Rail (Repaint)

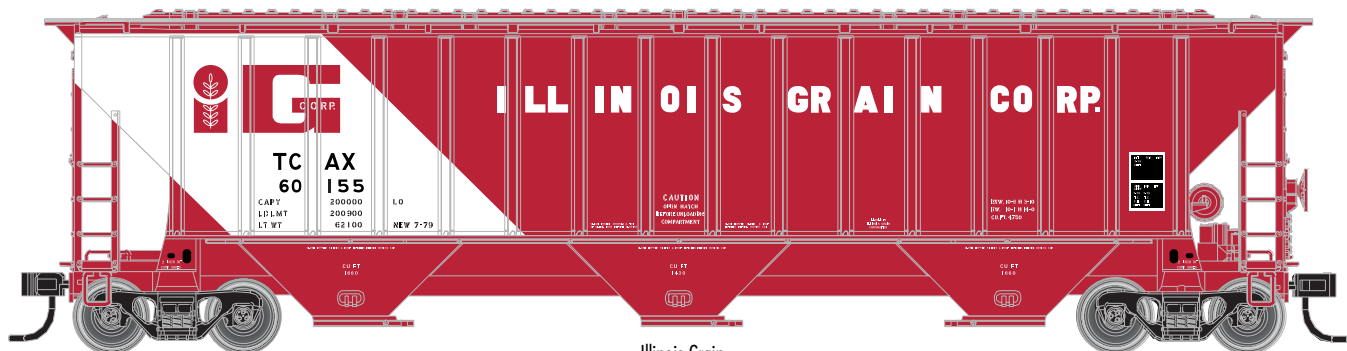

Illinois Grain

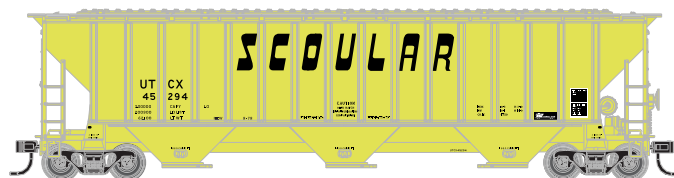

Scoular

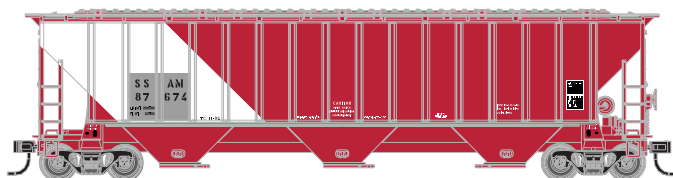

SSAM