

HO DIESEL LOCOMOTIVES

Atlas has an outstanding line of HO Locomotives. The success of these "State Of The Art" Locos is apparent by the sometimes difficult search model railroaders have in finding a desired road name a few weeks after the models arrive at local hobby stores. Please don't get discouraged! Atlas is committed to producing the finest locomotives to the highest standards that model railroaders can ask. Listed below are the latest models and roadnames for these popular Loco's.

The "Hottest" Locomotives on the right track are at your Model Railroad Hobby Store starting early 1990. The Locomotive Roadnames listed below were produced in very limited numbers—Place your order today.

EMD GP7 DIESEL LOCOMOTIVE



PROTOTYPE Photo from Louis A. Marre Collection

• DYNAMIC BRAKES

NEW

ITEM#	ROADNAME	D.B.*
8200	Undecorated	No
8201	Undecorated	Yes
8202	CB & Q #253	No
8203	CB & Q #265	No
8204	Santa Fe #2692	Yes
8205	Santa Fe #2752	No
8206	Canadian Pacific #8409	Yes
8207	Canadian Pacific #8411	Yes
8208	Rio Grande #5100	Yes
8209	Rio Grande #5112	Yes
8210	Erie Lackawanna #1217	Yes
8211	Erie Lackawanna #1401	No
8212	Pennsylvania #8508	Yes
8213	Pennsylvania #8797	No
8214	Southern #2067	No
8215	Southern #2185	Yes
8216	Union Pacific #703	Yes
8217	Union Pacific #718	Yes
8218	Western Maryland #21	No
8219	Western Maryland #23	No
8220	Rock Island #1202	No
8221	Rock Island #1300	No
8222	Clinchfield #902	No
8223	Clinchfield #913	Yes

ATLAS TOOL CO., 378 FLORENCE AVE., HILLSIDE, N.J. 07205 USA

ATLAS

1990

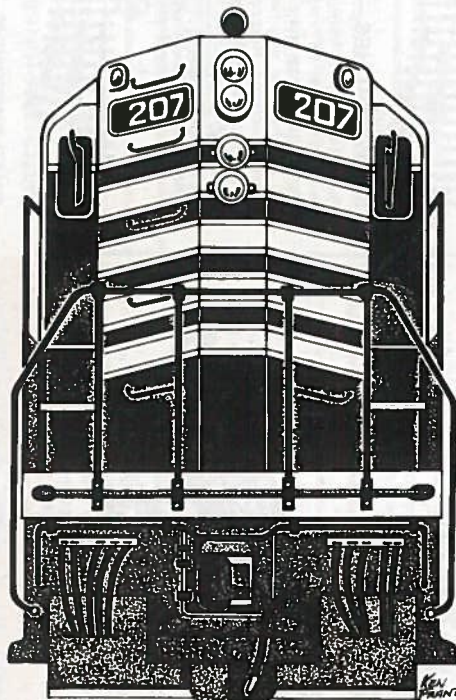

ALL SCALES CATALOG
HO, N & O SCALES

You're on the right track . . . with Atlas™

INDEX

HO Snap Track	2-4	N Freight Cars	16-19
HO Custom-Line Crossings	5	N Staked Flat Cars	20
HO Mark 2 Turnouts	6	N Model Railroad Sets	21
HO Bridges	7	N Locomotives	21
HO Buildings	8-9	N Locomotives	22
HO Accessories	10	O Freight Cars	23
HO Layout Plan Books	11	O Switches & Track	24
N Snap-Track	12-13	Electrical & Misc.	25-26
N Bridges	14	HO Locomotives	27
N Accessories	15		and cover
N Layout Plan Books	15	Price List	28-31

©1989

ATLAS TOOL, CO., INC. —
378 FLORENCE AVE., HILLSIDE, N.J. 07205



STRAIGHT SNAP-TRACK SECTIONS

BRASS RAIL

#21 9" long
#22 6" long
#23 3" long
#25 1½" long

N/S RAIL

#821 9" long
#822 6" long
#823 3" long



CURVED SNAP-TRACK SECTION

15" and 18" radius circles require 12 full sections
22" radius circle requires 16 full sections

BRASS RAIL

#31 15" rad.
#32 ½-15" rad.
#33 18" rad.
#34 ½-18" rad.
#35 1/3-18" rad.
#36 22" rad.

N/S RAIL

#831 15" rad.
#833 18" rad.
#836 22" rad.
#834 ½-18" rad.
#835 1/3-18" rad.

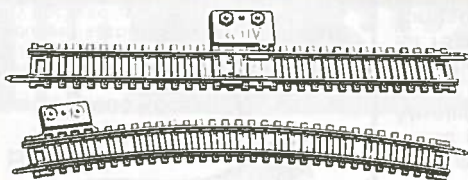

TERMINAL SECTIONS

For quick, solderless connections to track. See also pre-wired #42 Terminal Joiners on page 4.

#40 9" straight, brass rail #840 Nickel Silver
#45 18" radius curved, brass rail #845 Nickel Silver



36" SUPER FLEX TRACK™

Can be curved to any radius. Ideal for those realistic spiral easement curves. Easily cut to any needed length with the #400 Snap-Saw. (See page 25)

#104 Brass rail
#105 Brass rail - 5 pack
#168 Nickel-silver rail
#178 Nickel-silver rail - 5 pack



RERAILER #44 BRASS RAIL #844 N/S RAIL

Sweep of the hand places rolling stock on rails. Automatically rerails derailed equipment in hard to reach hidden areas.



#49 BRASS RAIL #849 N/S RAIL

DEAD-END UNCOUPLER

For use with horn-hook style couplers provided by most manufacturers of ready-to-run rolling stock. One-way ramp uncouples cars entering siding. Equipment remains coupled when leaving siding. Not for use on "through" lines.

HO SNAP-TRACK®

You're on the right track... with Atlas

America's most popular line of ready-to-lay sectional track. Atlas' large variety of realistic and precisely made sections can have you running trains in short order. Code 100 rail on molded wood-grained ties.

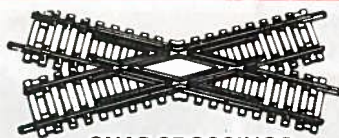

SNAP CROSSINGS

Each leg 6" long. See page 5 for Custom-Line Crossings available in many other angles of intersection.

#39 30° brass rail
#839 30° nickel-silver

#41 90° brass rail

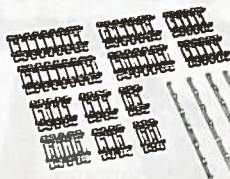

SNAP-TRACK ASSORTMENT

Easy way to fill short gaps in trackwork. Two each of 6 short pieces ¾", 1", 1¼", 1½", 2" and 2½".

#47 BRASS RAIL
#847 N/S RAIL

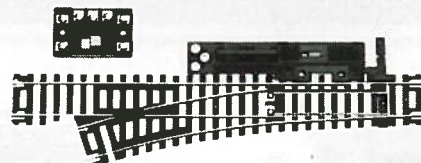

SNAP-SWITCHES—REMOTE CONTROL

Packed with ½-18" radius section making curved leg equal to regular 18" radius section. Adding passing tracks and sidings is a cinch as Atlas Snap-Switches will fit wherever you have 9" straight or 18" radius curved sections. Remote control Snap-Switches include switch machine, control box, hook-up wire and identification numbers.

#50 Lefthand, brass rail #51 Righthand, brass rail
#850 Lefthand, nickel-silver #851 Righthand, nickel-silver

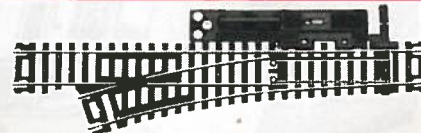

SNAP-SWITCHES—MANUAL

Manual Snap-Switches are easily convertible to remote control with #52LH and #53RH Switch Machines.

#60 Lefthand, brass rail #61 Righthand, brass rail
#860 Lefthand, nickel-silver #861 Righthand, nickel-silver

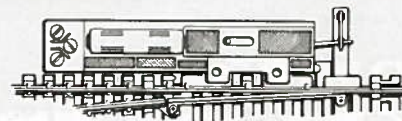

SWITCH MACHINES—REMOTE CONTROL

Snap-on switch machines will convert any Atlas manual switches to remote control in no time at all.

#52 Lefthand #53 Righthand

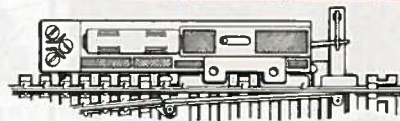

SWITCH MACHINES—MANUAL

For manual operation of switches located near control panel or other easily reached locations not requiring remote control operation.

#62 Lefthand #63 Righthand

REALISTIC WAY TO KEEP YOUR EQUIPMENT FROM ROLLING OFF THE ENDS OF SIDINGS. OVERALL LENGTH 3 3/8".

#43 BRASS RAIL

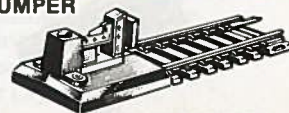

#843 N/S RAIL

TERMINAL JOINERS

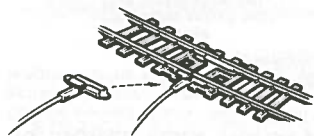

#42 Brass
#842 Nickel Silver

Easiest way to make power feeder connections to trackwork just about anywhere on layout. No soldering required.

HO SNAP-TRACK®



#100 ROADBED

Bevel edged, rubber-plastic roadbed in 3' lengths. Adds much to realism and reduces trackboard rumble. Curvable to any track radius.

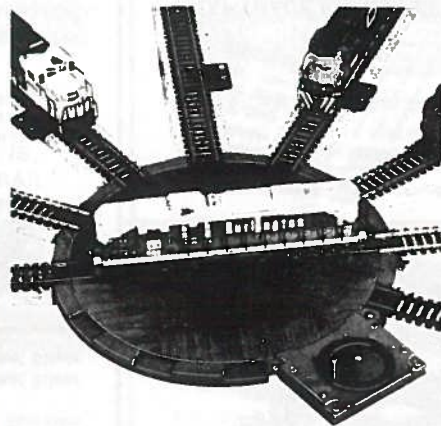

#302 TURNTABLE—MANUAL

Fully assembled 9" diameter turntable indexes precisely to 11 positions 30° apart. Absolutely no "hunting" required. Surface mount; no cutting necessary. Manual crank operation; can be very quickly motorized for remote control operation with the #301 Turntable Drive Unit shown at right.



#301
TURNTABLE DRIVE UNIT

Quickly attaches with just two screws to convert the Atlas #302 Turntable to remote control, motorized operation.



HO RAIL—SOLID "T" SHAPE

Code 100 rail for do-it-yourself track and turnout builders. Three-foot lengths in 99-foot bundles.

#101 Brass, 99' bundle
#102 Nickel-Silver, 99' bundle
#802 9" long N/S Rail
(Replacement for turntables, bridges, etc.)

HO SNAP-TRACK®

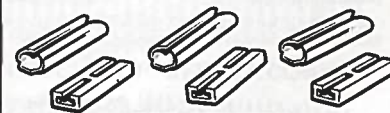

RAIL JOINERS

#54 Brass
#170 Nickel-Silver
#55 Plastic Insulating

HO

Custom-Line

CROSSINGS

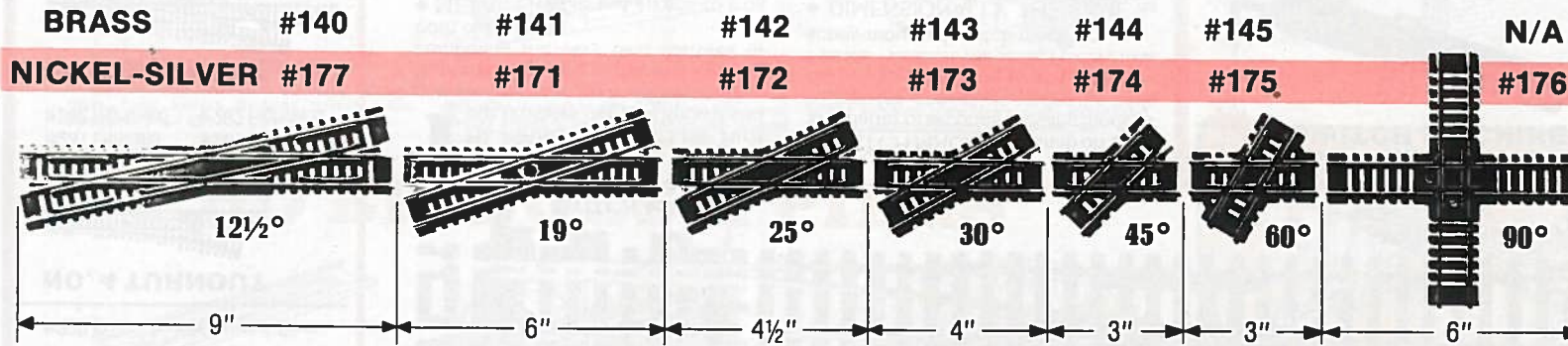

SEVEN PRECISELY ENGINEERED angles of intersection provide an easy solution to just about any crossing requirement. For scissors crossovers, use either the 25° crossing with #4

Custom-Line Mark 2 Turnouts or the 19° crossing with #6 turnouts. The 12 1/2° and 19° crossings are especially suited for junctions between double-track mainlines. A wide variety of single and

double-track wyes, along with numerous other useful arrangements, appear in the *Track Planner* section at the back of Atlas' *Custom-Line Layouts* book.

HO

Custom-Line Mark 2 Turnouts

HO

WYE TURNOUT



#230 Brass #260 Nickel-Silver

NO. 4 TURNOUT



BRASS **N/SILVER**
 #231 Lefthand #261 Lefthand
 #232 Righthand #262 Righthand

NO. 6 TURNOUT



BRASS **N/SILVER**
 #233 Lefthand #263 Lefthand
 #234 Righthand #264 Righthand

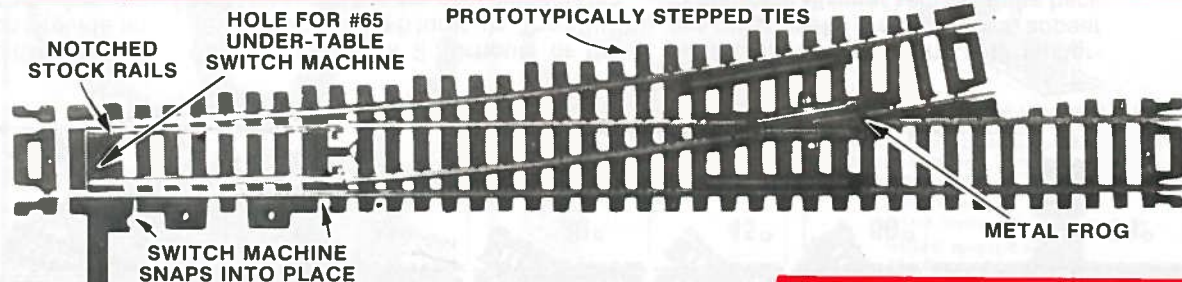

THE MARK 2 Custom-Line Turnout replaces our well known and popular Custom-Line and Custom-Line Supreme Turnouts while retaining and combining the very best features of both older lines.

- **METAL FROGS** put an end to frog point wear on busy layouts. Best of all, when hooked up with the new Atlas #200 SNAP RELAY, described on page 25, the frog will be powered thus eliminating the old stall-causing dead spot common to all plastic frog turnouts.

- **SWITCH MACHINES** snap on or off in a matter of seconds allowing modeler to opt for concealed under-the-table mounting or a manual ground throw. Mark 2 Turnouts will accept older Atlas screw-mounted switch machines.

- **DIMENSIONALLY THE SAME** as earlier Custom-Line and Custom-Line Supremes, the new Mark 2's can be intermixed with the older turnouts without problem.

NEW

#65 UNDER-TABLE SWITCH MACHINE



Designed for use with all ATLAS HO SNAP SWITCHES and MARK 2 TURNOUTS. (May be used with ATLAS N SCALE SWITCHES).



#83 WARREN TRUSS KIT

Assembles in minutes into authentic through truss. Floor system contains built-in track. Measures 9" x 2" x 2 1/2".

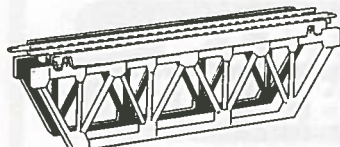

#84 DECK TRUSS KIT

Fun-to-build kit quickly assembles into realistic deck truss. A string of several of these handsome bridges makes a genuinely impressive railroad scene. Floor system contains built-in track. Measures 9" long x 1 3/4" wide x 2 1/4" high.

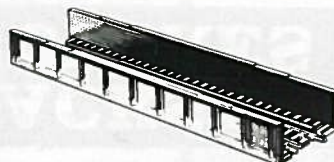

#85 PLATE GIRDER

Striking replica of scale 65' through plate girder bridge with steel plate floor system. Assembled, ready to install including track. Measures 9" long.

#81 3" BRIDGE PIER

Cut stone masonry pier, 3" high, supports and securely aligns all Atlas bridges and track by means of rugged snap-lugs.

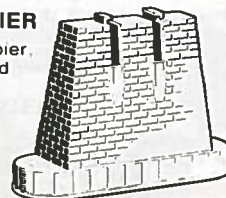

HO BRIDGES & PIERS *

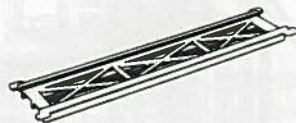

#82 PIER GIRDER

Adds realism and strength to end supported track on piers spaced 9" apart. Ideal where intermediate support piers must be omitted to permit passage of track.



#86 PONY TRUSS

This finely detailed, simple to construct bridge kit is suitable for any ATLAS layout. Its 9" length substitutes exactly for a 9" section of SNAP-TRACK.



#87 CURVED CHORD

A full 18" long, this bridge meets the need for a big bridge without overpowering a layout. Both #86 and #87 are easily adaptable to ATLAS Bridge piers.

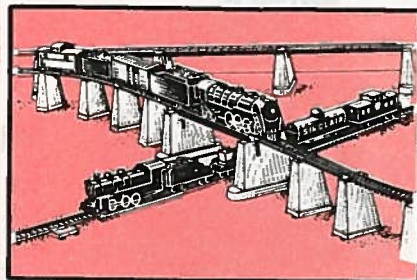

#80 OVER 'N UNDER PIER SET

Forty-six stone masonry piers and a #82 Pier Girder. Piers are graduated in height from 1/2" to 3" by 1/4" increments with 1/8" snap-in shims provided for intermediate piers. Approximate grades up and down in figure-8 arrangement using 18" radius curves is 2.6%.

* ALSO AVAILABLE IN NICKEL SILVER, SEE PAGE 28

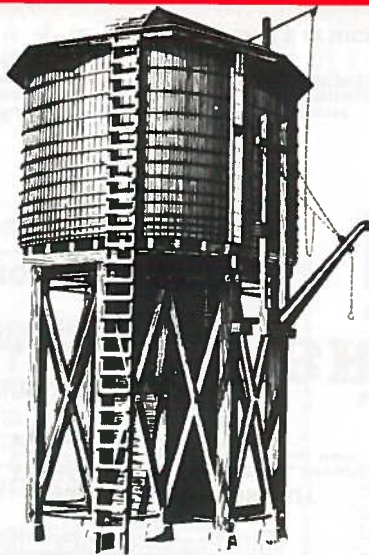

#703 WATER TOWER

The all-time best selling HO water tank and for good reason. Absolutely authentic down to the smallest detail including the padlock on the roof trapdoor.



#750 LUMBER YARD & OFFICE BUILDING

You will want to locate this nifty piece of modeling craftsmanship along your most prominent industrial siding. Devotion to authenticity bordering on fanaticism is evident in detailing which includes a radial-arm power saw and hand tools usually to be found around a lumber yard's saw table.

HO TRACKSIDE STRUCTURES



#701 ELEVATED GATE TOWER

Provides just the right railroad atmosphere at your grade crossings with its typical clutter of detail even down to such items as coal scuttle and lamps.



#760 ROADSIDE RESTAURANT

You'll enjoy a long evening's fun assembling this little beauty whose 'gnat's eyebrow' detailing includes even such mundane items as the refuse cans around back.



#707 STATION PLATFORM (set of 2)

A perfect companion piece to the #706 Passenger Station. Use it to lengthen the station platform or to provide an across-the-tracks shelter opposite your station.

Featured on these two pages is the Atlas premier line of trackside structure kits. Made in the U.S. to strict American prototype and super-detailed to satisfy the fussiest modeler with absolutely no concessions to manufacturing convenience or economy. All parts precision molded in appropriate colors. Kits include easy-to-follow instructions, decals and printed window glazing where required. Fun and really satisfying to assemble; try one and you'll be back for the rest.



#706 PASSENGER STATION

An exquisite model with a host of realism-heightening details such as a baggage wagon loaded with express and luggage, freight scale and dolly and even a phone booth complete with tiny phone inside.

#702 TRACKSIDE SHANTY

Typical of the countless unpretentious little shanties to be found in any number of railroad scenes. All the finishing touches including the checkers-playing crew seated on their salvaged orange crate chairs.



#705 TELEPHONE SHANTY & POLE



Provides just the right touch beside that lonely branch or siding turnout along the main.



#704 SIGNAL TOWER

A pleasant evening's fun provide a model of contest-quality detailing which includes such niceties as partially open window sashes with window shades, some in disreputable condition, drawn to various heights.

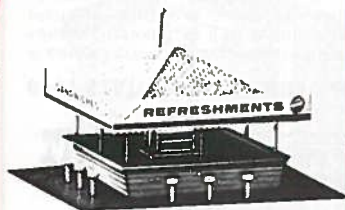

#715 REFRESHMENT STAND

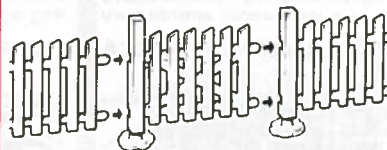

#776 PICKET FENCE & GATE

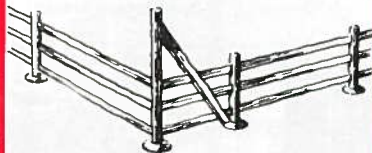

#777 RUSTIC FENCE & GATE

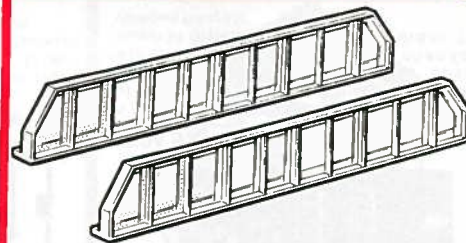

#790 FLATCAR GIRDER LOAD

HO ACCESSORIES

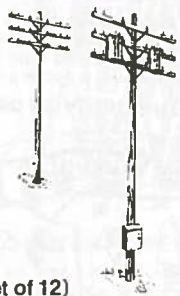

(set of 12)

#775 TELEPHONE POLES

#793 24 FIGURES
-ALL DIFFERENT

#778 COWS & HORSES

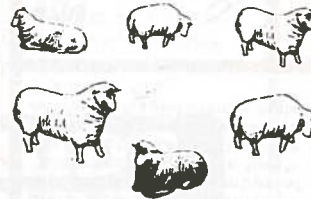

#779 SHEEP (12 White, 1 Black)

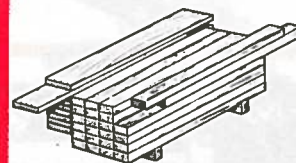

#791 MILL LUMBER

NEW

#8 BASIC GUIDE TO MODEL RAILROADING



HOW-TO-DO-IT BOOKS BY ATLAS

From simple oval with sidings to elaborate room-size walkins, if your HO layout is to be built with sectional track, you can't find a better way to start than with an Atlas book. Illustrated with hundreds of photos and drawings, these authoritative manuals will help you steer clear of discouraging errors. In addition to layout plans with full wiring information you'll find chapters on benchwork and scenicking. Best of all, every necessary track item called for is always available from Atlas.



#9 BLUEPRINTS FOR HO SNAP-TRACK LAYOUTS REVISED

Best choice for HO beginners. Twelve excellent layouts all buildable on easily available standard plywood panel sizes.

#11 HO CUSTOM LINE LAYOUTS 2nd Edition

Second edition of all-time best seller since 1957. Complete instructions for ten all different layouts plus seven pages of track planning templates with which a beginner can design a layout of any complexity and be sure it will work.

#12 WIRING YOUR LAYOUT 3rd Edition

Easy to follow text and drawings show how to wire just about any track arrangement using the various popular Atlas control components shown on page 20. Turnouts, sidings, wyes, reverse loops, turntables and all manner of other model railroad electrical questions are fully covered.

#13 SIX HO RAILROADS 2nd Edition

Six great fully tested model railroads. Completely illustrated step-by-step instructions cover every stage of construction including benchwork, tracklaying, wiring and scenery.

#14 KING SIZE HO RAILROADS PLAN BOOK

Measures 34" across when opened. Large photos and 2" to the foot (1/4th full size) plans give you a real feel for six superb entirely different model railroads. From benchwork through scenery every step of the way is covered in detail.



#2501 STRAIGHT (5") SNAP-TRACK



#2509 SNAP-TRACK ASSORTMENT

Contains two 2½", four 1¼" and four ¾" sections
Easiest way to fill short gaps in sectional track lay-
outs



#2532 RERAILER TRACK SECTION

Sweep of the hand places rolling stock on track
Automatically rerails derailed equipment in hard to
reach hidden areas

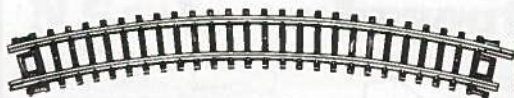

CURVED SNAP-TRACK

- #2510 9¾" Radius Full Section
- #2511 Half Section 9¾" Radius
- #2520 11" Radius Full Section
- #2521 Half Section 11" Radius
- #2526 19" Switch Rad (24 Sections/circle)



#2500 SUPER - FLEX TRACK™

Curvable to any radius. Ideal for spiral easement
curves. Easily cut to any needed length with a #400
Snap-Saw (See page 26)

N**SNAP-TRACK®****N***Makes tracklaying a 'Snap'!*

USA SERIES



SWITCHES - MANUAL & REMOTE

- #2580, 2580-1 Lefthand Standard Remote Control
- #2581, 2581-1 Righthand Standard Remote Control
- #2582, 2582-1 Lefthand Standard Manual Control
- #2583, 2583-1 Righthand Standard Manual Control
- #2584 No. 6 Lefthand Remote Control
- #2585 No. 6 Righthand Remote Control

The -1 series denotes new ATLAS manufactured USA
switches.

Remote control switches include the #56 Switch Control Box
shown below.

Manual Switches #2582 and #2583 can be converted to remote
control with Switch Machines #2590 (lefthand) and #2591
(righthand). #2582-1 and #2583-1 can be converted to remote
control with Switch Machines #2590-1 and #2591-1, shown
below.



SWITCH MACHINES—REMOTE CONTROL

- #2590 Lefthand
- #2590-1 Lefthand
- #2591 Righthand
- #2591-1 Righthand

NOTE: All twin-coil switch machines must be con-
trolled by a normally-off, momentary contact switch.
Using any control device of other than momentary
contact type will cause burn-out failure of the ma-
chines solenoid coils. Switch machines are not war-
ranted against burn-outs thus caused. The #56
Switch Control Box is recommended.

#56 SWITCH CONTROL BOX



Single pole, double
throw momentary ac-
tion for control of
Atlas (or other twin-
coil) switch machines.
Button position indi-
cates switch setting. Can be coupled to-
gether in any number without wiring. Switch
identification labels included.

CROSSINGS - 15°, 20°, 30°, 45°, 60°, 90°

Joining the popular ATLAS
90° crossing is a complete
line of crossings that allows
the modeler the widest
possible choices of track
crossing arrangements.

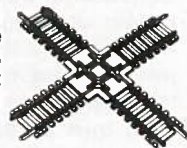

- 2564 - 15°
- 2565 - 20°
- 2566 - 30°
- 2567 - 45°
- 2568 - 60°
- 2569 - 90°

Realistic way to keep your
equipment from rolling
off the ends of sidings
Overall length 2¾"

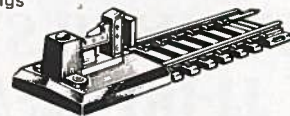

#2536 SNAP-TRACK BUMPER

#2539

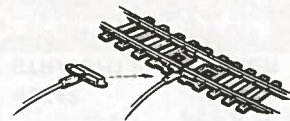
TERMINAL
JOINERS

Easiest way to make power connections to track-
work just about anywhere on layout. No soldering
required.

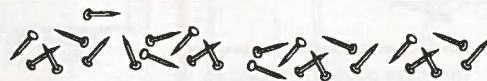

#2540 TRACK NAILS (ALSO FOR HO)

Just the right size for fastening down sectional track.
Approximately 400 nails per package

RAIL JOINERS

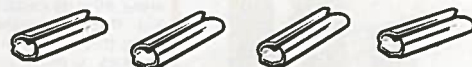

#2535 Metal Rail Joiners

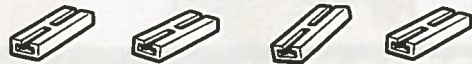

#2538 Clear Plastic Insulating Joiners

N Scale

BRIDGES & PIERS

N Scale

HIGHLY DETAILED AND AUTHENTIC BRIDGES READY TO INSTALL

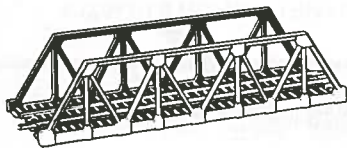

#2546 WARREN TRUSS

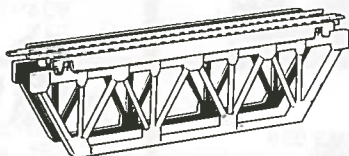

#2547 DECK TRUSS

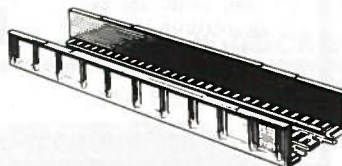

#2548 PLATE GIRDER

All same length as standard 5" straight section. Snap them together atop the #2543 Bridge Piers in any number and arrangement for an impressively realistic multi-span structure.

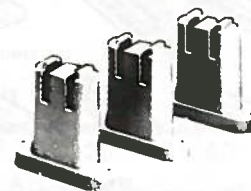

#2543 BRIDGE PIERS

Poured concrete piers, 1 1/16" high, securely support and align all Atlas bridges and track by means of rugged snap-lugs

Easy to build kit assembles into impressive 4-arch cut stone masonry single-track viaduct. Arches are 2 3/4" center-to-center and 3 1/4" high. Can be joined end-to-end for any length viaduct and piers are easily shortened to any desired height. Arch assembly without piers is 1" high.

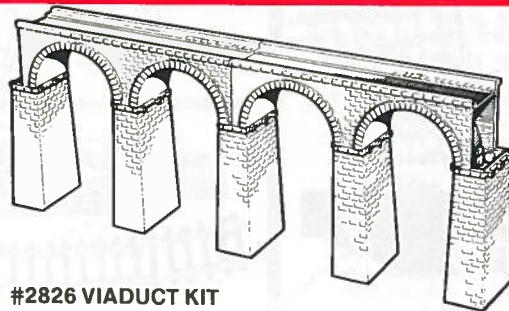

#2826 VIADUCT KIT

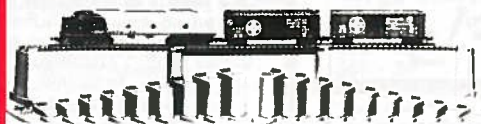

#2541 OVER 'N UNDER PIER SET

Two each of 12 graduated concrete piers plus #2542 Straight Pier Girder. Pier heights range from 3/4" through 1 1/16" by 1/64" increments. Grade with piers spaced at 5" intervals is 2 8/8%.

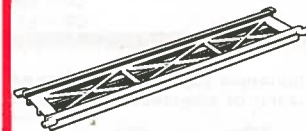

#2542 STRAIGHT PIER GIRDER

Add realism and strength to end-supported track on bridge piers. Straight girder is 5" long.

N Scale

Layout Plan Books

N Scale

Accessories

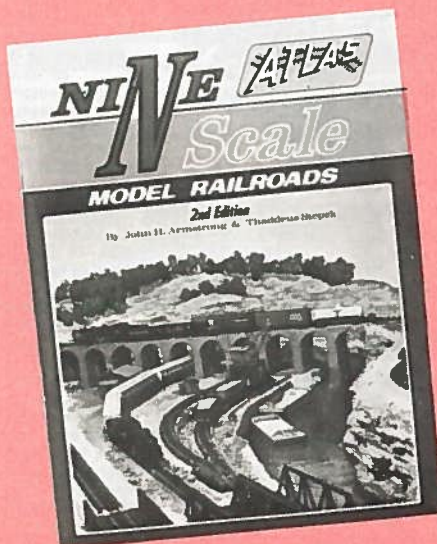

#7 NINE N SCALE MODEL RAILROADS 2nd Edition

The N Scale layout plan book. Nine elegant railroads with full step-by-step instructions for benchwork, track-laying, wiring and scenery. Beautifully illustrated with dozens and dozens of large photos, this is the book that will get you hooked!



#6 A CLEAR TRACK TO N GAUGE FUN 4th Edition Revised

Ideal for beginners. Nine interesting layouts all buildable on flat table top. Complete wiring instructions plus chapters on benchwork and tracklaying; 28 pages.

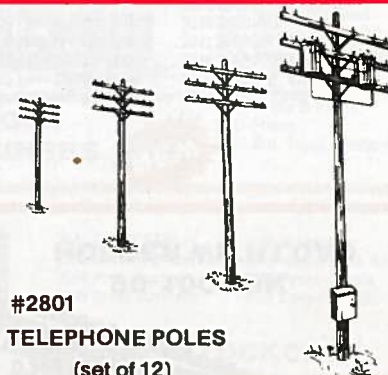

#2801 TELEPHONE POLES (set of 12)



#791 MILL LUMBER

N Scale

FREIGHT CARS

MADE IN THE U.S.

3201 Canadian National
3202 Union Pacific (Alum.)
3203 Minnesota Smelting
3204 Bessemer & Lake Erie
3205 Burlington Northern
3206 Milwaukee Road
3207 Utah Copper
3208 Duluth & Two Harbors
3209 Escanaba & Marquette
3210 Great Northern (Blue)
3211 Erie Mining
3212 Chicago & North Western
3213 Union Pacific (Red)
3215 Northern Pacific
3216 Thunder Bay Mining
3217 Great Northern (Green)
3218 Southern Pacific



ORE CAR WITH LOAD

3220 Santa Fe
3221 Duluth Missabe & I.R.

3222 Pennsylvania
3223 S00 Line

3261 Burlington (CB&Q) Alum.
3262 Burlington (CB&Q) Red
3263 Union Pacific
3264 Norfolk & Western
3265 Western Maryland (Gray)
3266 Western Maryl. (Tuscan)
3267 MKT (KATY)
3268 Santa Fe
3269 Ontario Northland
3270 Erie Lackawanna
3271 Delaware & Hudson
3272 Southern
3273 Rio Grande
3274 Reading
3275 Clinchfield
3276 Pennsy. R.R.
3277 Conrail

3278 Chesapeake & Ohio
3279 New York Central
3280 Burlington Northern

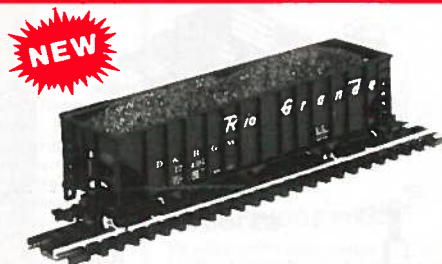
90-100 TON
HOPPER WITH LOAD

3231 Wyandotte (Green)
3233 Dow Chemical
3234 Eastman Chemical
3237 Hooker
3238 Hudson Bay Oil
3239 Firestone
3240 Wyandotte (Blue)
3241 Atlas Chemical
3242 Brea Chemical
3243 Dupont
3244 Standard Chemical
3245 Southern Star Lard
3246 CPC International
3247 FMC Corporation
3248 Canadian Gen'l

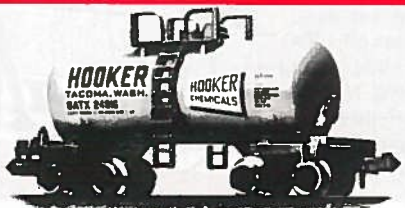
"BEERCAN"
SHORTY TANKCAR

40' PLUGDOOR BOXCAR

3301 Western Pacific
3302 Penn Central
3303 Chessie System
3305 Western Maryland
3306 Chesapeake & Ohio
3308 Pickens Railroad
3309 Rio Grande
3310 Delaware & Hudson
3312 Chattahoochee Ind.
3313 Evans Products

3314 Illinois Central
3315 L'ville N. Alb. & Cor.
3316 Milwaukee Road
3317 Ralston Purina
3318 Southern
3319 Baltimore & Ohio
3321 Pennsylvania
3323 S00 Line
3325 Canadian Pacific
3326 Am. Refrig. Transit

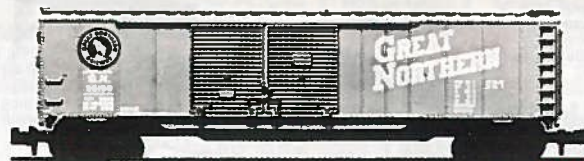
50' STAGGERED
DOUBLE-DOOR BOXCAR

3601 Great Northern
3602 Family Lines
3604 Illinois Central Gulf
3605 Pennsylvania
3606 Reading
3608 Canadian Pacific
3609 Northern Pacific
3612 Southern
3625 Southern Pacific
3626 B & O Sentinel

42' GONDOLA
WITH CONTAINERS

3501 L'ville & Nashville
3502 Ill. Terminal Co.
3503 Seab'd Coast Line
3504 Milwaukee Road
3505 Ontario Northland
3506 Norfolk & Western
3508 Southern
3509 Penn Central
3510 Texas & Pacific
3511 Frisco
3512 Grd. Trunk Western

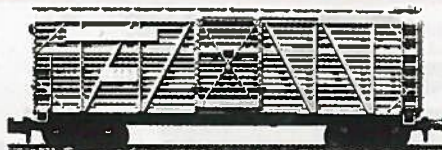

3522 Rio Grande
3523 Great Northern
3524 Southern
3525 Union Pacific
3526 Wabash



3541 Burl (CB&Q)
3542 Norfolk & West'n
3544 Penn Central
3545 Great Northern

3546 Wabash
3547 Nickel Plate Rd.
3549 Pennsylvania
3551 Canadian Nat'l

40' PSI BOXCAR

3401 Atlantic Coast Line
3402 Erie Lackawanna
3403 Norfolk & Western
3405 Milwaukee Road
3406 Vermont Railway
3407 Burlington Northern
3408 Grd. Trunk Western
3409 Soo Line
3410 Central New Jersey

3411 Reading
3412 Louisville & Nashville
3413 Rich. Fred. & Poto.
3414 Illinois Central Gulf
3416 The Rock
3417 SL-SF Frisco
3418 Seaboard Coast Line
3419 Santa Fe (map)



40' PSI BOXCAR

3420 Union Pacific
3421 NYC Pacemaker
3422 Penn (Don't Stand me Still)
3423 Rio Grande
3424 B & O Sentinel
3425 New Haven
3426 Canadian National
3427 Jersey Central
3428 Great Northern

3429 Cotton Belt
3430 Gulf, Mobile & Ohio
3431 B & O Timesaver
3432 Western Pacific
3433 Penn Merchandise Ser.
3434 CB & O
3435 NYC Early Bird

N Scale

FREIGHT CARS

N Scale

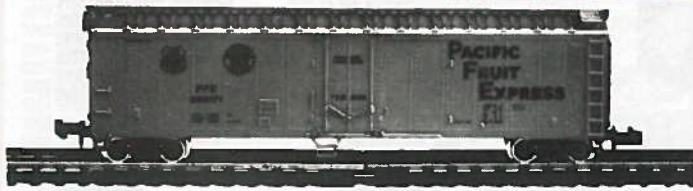
**50' MECHANICAL REFRIGERATOR REEFER**

3652 Bangor & Aroostook	3662 Swift Meats
3653 Burlington Northern	3667 Santa Fe
3654 Canadian National	3670 Tropicana
3661 Pacific Fruit Express	3671 Fruit Growers Express

NEW**CUPOLA CABOOSE****NEW**

3561 Southern Pacific	3565 Burlington Northern	3569 Rio Grande
3562 Union Pacific	3566 Louisville & Nashville	3570 Norfolk & Western
3563 Santa Fe	3567 Seaboard Coast Line	3571 Chicago Northwestern
3564 Western Pacific	3568 Lehigh Valley	3572 Burlington (CB & Q)

3573 Southern
3574 Chessie System
3576 Baltimore & Ohio
3577 Erie Lackawanna
3579 Family Lines
3583 Pennsylvania
3584 Penn Central
3585 Reading
3587 Western Maryland
3589 Great Northern
3590 Conrail
3591 Canadian Pacific
3592 Canadian National

ACF CENTER FLOW 4 - BAY COVERED HOPPER

3701 Union Pacific
3702 Southern Pacific
3703 Burlington Northern
3704 Rio Grande

3705 Conrail	3709 Engelhard
3706 Erie Lackawanna	3710 Soo Line
3707 Southern	3711 Chicago Northwestern
3708 Pennsylvania	3712 Shell Chemical
	3713 DuPont Alathon

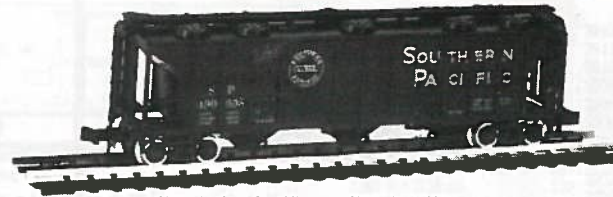
3-BAY COVERED HOPPER

3720 Union Pacific	3723 L & N
3721 Southern Pacific	3724 Reading
3722 Southern	3725 Conrail

ALL N SCALE FREIGHT CARS AVAILABLE IN UNDECORATED - SEE PRICE LIST**N Scale 50' PIGGYBACK TRAILER FLATS N Scale****40' TRAILER TRUCK**

This is the latest ATLAS N scale freight car - a 50' trailer flat with a large 40' trailer truck. Take a close look at the rear door detail and the beautiful side and end printing.



3770 - Undecorated
3771 - Maine Central

3772 - Chicago & Northwestern
3773 - Missouri & Pacific
3774 - Pennsylvania
3775 - Santa Fe
3776 - Pacific Fruit Express
3777 - Canadian Pacific Express

24' TRAILER TRUCKS

Each 50' trailer flat comes with 2 removeable 24' highway trailers. All trailer flat roadnames are matched with an appropriately named tractor trailer being carried. Mix and match, or make your own with the undecorated version.

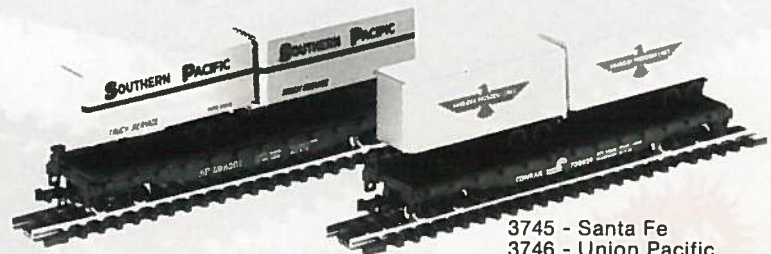

3740 - Undecorated
3741 - Sea Land
3742 - Conrail
3743 - L & N
3744 - Southern Pacific

3745 - Santa Fe
3746 - Union Pacific
3747 - Illinois Central
3748 - Rio Grande
3749 - B & O
3750 - NYC Pacemaker
3751 - Pennsylvania
3752 - REA Leasing
3753 - American Pres. Lines

N Scale

STAKED FLAT CARS

N Scale

NEW

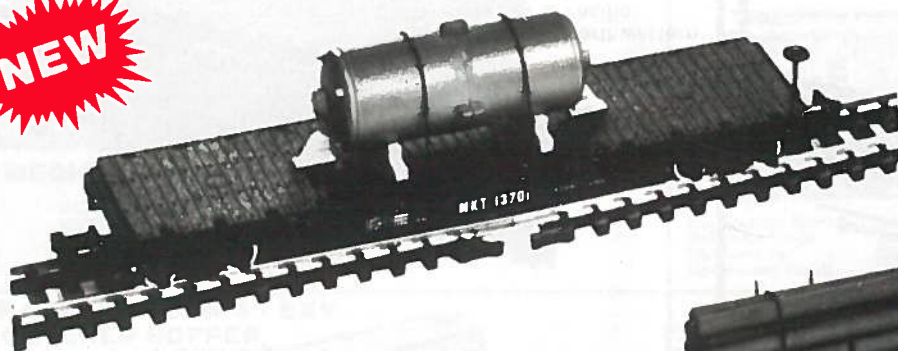

NEW



ROADNAMES

3800 - Undecorated	3807 - Great Northern
3801 - Burlington Northern	3808 - Missouri, Kansas, Texas
3802 - Bessemer & Lake Erie	3809 - Northern Pacific
3803 - Chesapeake & Ohio	3810 - Seaboard Airline
3804 - Canadian Pacific	3811 - Southern
3805 - Erie	3812 - Wabash
3806 - SL-SF (Frisco)	3813 - Western Maryland

Loads not included.

N Scale MODEL RAILROAD SETS

N Scale DIESEL LOCOMOTIVES

NEW

N SCALE STARTER SETS FROM
ACROSS THE U.S.A. & CANADA

ATLAS N SCALE Nickel Silver SNAP-TRACK STARTER SET

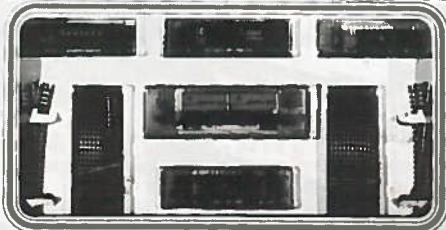

SOME SETS
NOW
AVAILABLE
WITH
LOCOMOTIVES

- CONRAIL
- PENNSYLVANIA
- NORFOLK & WESTERN

THE SNAP-TRACK SYSTEM IS A REGISTERED TRADEMARK OF ATLAS MODEL TRAINS, INC. © 1987 ATLAS MODEL TRAINS, INC.

You're on the Right Track.....with ATLAS!

CONTENTS:

Your "Snap-Track" Starter Set contains the following Nickel Silver Track Items

5" Straight Section	1	RH Manual "Snap Switch"	1
Rerailer Section	1	Wired Terminal Joiners	2
9 1/2" Radius Sections	17	Rail Joiners Freight Cars	5
LH Manual "Snap Switch"	1	Booklet "A Clear Track TO N Gauge Fun."	

Power Pack not included.

ROADNAME SETS

4448-1 Pennsylvania
4448-2 Southern
4448-3 Santa Fe
4448-4 Union Pacific
4448-5 Baltimore & Ohio
4448-6 Canadian
4448-10 Conrail
4448-11 Norfolk & Western
4448-12 Pennsylvania

FEATURES:

- Dual Brass Flywheels
- Fantastic Detailing
- Powerful and Quiet 5 Pole Motor
- State of the art circuitry—No wiring
- Diode controlled directional lighting—Can be replaced in seconds

ALCO RS-1



4400 - Undecorated (friction bearing truck)
4401 - Undecorated (roller bearing truck)
4402 - Santa Fe #2396
4403 - Santa Fe #2394
4404 - Pennsylvania #5906
4405 - Pennsylvania #9914

4406 - Soo Line
4407 - Baltimore & Ohio
4408 - New Haven
4409 - Gulf, Mobil & Ohio
4410 - Spokane, Portland & Seattle
4411 - Amtrak
4412 - Southern
4413 - Great Northern

N Scale**DIESEL LOCOMOTIVES****N Scale****GE U25B - 2 RUNS****2 PIECE HANDRAIL/SIDESILL - NEW MOTOR****1st RUN****Phase II a**

- 4450 Undecorated
- 4451 Santa Fe
- 4452 Pennsylvania
- 4454 Conrail

Phase II b

- 4470 Undecorated
- 4471 Burlington Northern
- 4472 Erie Lackawanna
- 4473 Seaboard System
- 4474 Rock Island

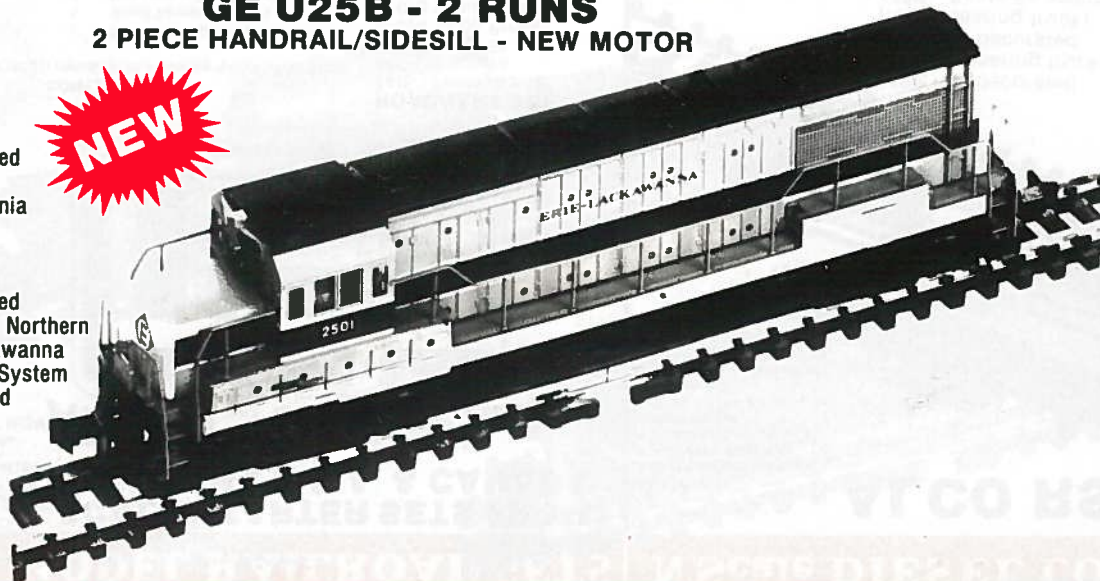
**2nd RUN****Phase II a**

- 4455 Chesapeake & Ohio #2500
- 4456 Chesapeake & Ohio #2537
- 4457 Frisco #812
- 4458 Frisco #814
- 4459 Southern Pacific #6706
- 4460 Southern Pacific #6714
- 4461 Wabash #502
- 4462 Wabash #505

Phase II b

- 4475 New York Central #2525
- 4476 New York Central #2529
- 4477 New Haven #2502
- 4478 New Haven #2509
- 4479 Great Northern #2500
- 4480 Great Northern #2502
- 4481 CB & Q #100
- 4482 CB & Q #105

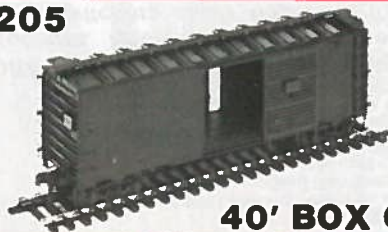
O Scale**FREIGHT CARS****O Scale****Finely Detailed, Easy to Assemble, Undecorated Kits****#6205****40' BOX CAR****#6225****40' STOCK****#6235****CABOOSE****#6245 40' PLUG DOOR**

- Sliding doors on prototypical guides
- Separately applied brake rigging

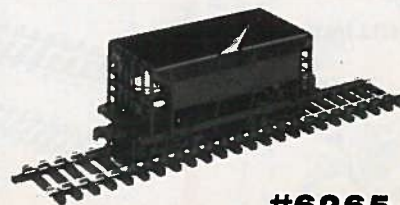
**#6265 70 TON ORE**

- Murphy diagonal roofs
- Easily snaps together

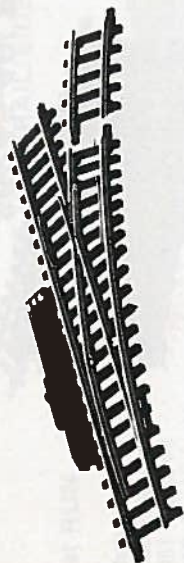

SWITCHES

#6021 Lefthand Remote
#6022 Righthand Remote
#6023 Lefthand Manual
#6024 Righthand Manual

IDEALLY SUITED for O gaugers with severe space problems. Short-wheelbased diesels, 0-4-0 and 0-6-0 switchers easily negotiate the 24" radius curves. Great for trolley and interurban layouts and layouts that have to be taken up and put away.



TRACK SECTIONS

#6000 36" Flex-Track
#6001 12" Straight Section
#6004 4" Straight Section
#6010 24" Radius Section
#6014 1/2" 24" Radius Section
#6018 Terminal Track Section

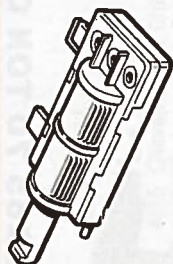

SWITCH MACHINES

#6031 Lefthand
#6032 Righthand

METAL RAIL JOINERS

#6041



HO STARTER SET



NEW PACKAGE

#88 NICKEL SILVER STARTER SET

Starting a model railroad layout? For a rewarding experience, try the new Atlas HO Starter Set! It's a "snap" to assemble because the Starter Set is made up of "Snap-Track", a proven model track system developed and manufactured exclusively by Atlas. Ideal in size, the Starter Set contains enough track for a 40" x 56" layout with 2 sidings.

SAME PRODUCT, NEW PACKAGE

ELECTRICAL

#200

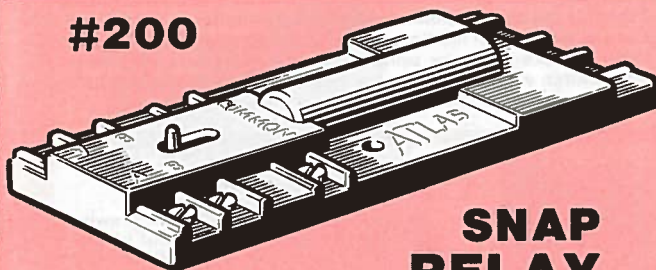

SNAP RELAY

a double-pole, double-throw relay with actuating mechanism driven by momentary-power, twin coil solenoid.

WHAT IT WILL DO

With just a few simple connections this little (1-5/16" x 3-9/16") device, which can be mounted anywhere, will perform all sorts of tricks for you:

- **POWER THE FROGS** on Atlas' new Mark2 Turnouts. No more hesitation or stalling on dead turnout frogs.
- **TRACKSIDE SIGNAL LAMPS** to show turnout point position in yards.
- **CONTROL PANEL LAMPS** to show settings of remotely located turnouts.
- **SELECTIVE SIDING CONTROL.** Sidings are powered only when points are aligned for siding. Siding remains "dead" when points are set for the mainline.
- **CONTROL X-SECTIONS** automatically. This very useful track arrangements is thoroughly discussed in the 3rd Edition of the Atlas "Wiring" book.

ELECTRICAL CONTROLS

Probably the most popular control panel switches in model railroading. Consist basically of multiple sets of the most often needed switch types internally pre-wired by printed circuitry. Eliminate all behind-panel, inter-switch wiring; you just run connections to the tracks. All are flush mounting; no need to drill large holes in panel.



#215 SELECTOR

Four single-pole, double-throw switches provide two-cab operation for four blocks. May be ganged together in any number for control of additional blocks without inter-switch wiring. Can be used as area selectors for four-cab operation. Couples with #220 Controller below.

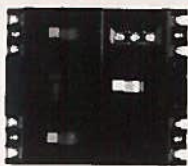

#220 CONTROLLER

Simplest way to wire and control tricky reversing loops, wyes and turntables. Has reversing switches for two mainline cabs plus a switch, selectable by either cab, for directional control on reversing loops, etc. Couples with #215 Selectors above.

#210 TWIN



Two DPDT switches in parallel. Useful for reversing section and turntable control on single-cab layouts plus many other applications.

#205 CONNECTOR

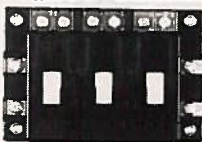

Three SPST on-off switches in parallel. Use to control power to sidings, accessories, etc. Can be ganged (coupled) together in any number.

#56 SWITCH CONTROL BOX



Single pole, double throw momentary action for control of Atlas (or other twin-coil) switch machines. Button position indicates switch setting. Can be coupled together in any number without wiring. Switch identification labels included.

#400 SNAP-SAW



A long lasting, all-purpose saw for model builders. Extra-fine teeth make razor smooth cuts in wood, plastics, brass, nickel-silver, etc. Ideal for making short track-filler sections.

C199 FORMULA XX MOTOR LUBE



Ideal for model railroad equipment. Won't dry out or gum. Safe for plastics. Use on motor shaft bearings, axles, etc.

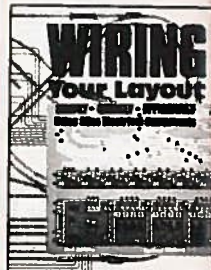

#12 WIRING YOUR LAYOUT

Easy to follow text and drawings show how to wire just about any track arrangement using the various popular Atlas control components shown on this page. Turnouts, sidings, wyes, reverse loops, turntables and all manner of other model railroad electrical questions are fully covered.

MISCELLANEOUS

HO

DIESEL LOCOMOTIVES

HO

ALCO RS-1

ROADNAMES
8123 Great Northern
8124 Milwaukee Road
8125 Susquehanna
8126 Santa Fe #2395
8127 Santa Fe #2398

ALCO S-2

ROADNAMES
Pennsylvania - 8073
New York Central - 8074
Undecorated - 8070
Rio Grande - 8071
Baltimore & Ohio - 8075
Union Pacific - 8072
Seaboard Air line - 8076

ALCO RS-1

ROADNAMES
8123 Great Northern
8124 Milwaukee Road
8125 Susquehanna
8126 Santa Fe #2395
8127 Santa Fe #2398

ALCO S-2

ROADNAMES
Pennsylvania - 8073
New York Central - 8074
Undecorated - 8070
Rio Grande - 8071
Baltimore & Ohio - 8075
Union Pacific - 8072
Seaboard Air line - 8076

FEATURES:

- All metal die cast chassis.
- Powerful 5 pole flat can motor
- Superb fidelity to prototypical detail
- A heavyweight with excellent tractive effort and pulling power
- Dual flywheels that provide a remarkably smooth running mechanism
- Simply designed coupler pocket for easy installation of Kadee® couplers
- Undecorated chassis is painted black.

FEATURES

- Fine prototypical detail
- Strong, smooth 5 pole motor
- Dual brass flywheels
- Lighted and printed number boards
- 8 wheel drive
- Geared for low speed and pulling power
- Heavy metal cast main frame
- Weight - .88 lbs. (heavier than most S-2 brass models)

ALL SCALES PRICE LIST

The prices found below are suggested retail as of 11-1-89. They are subject to change without notice.

HO SCALE PRODUCTS HO SCALE PRODUCTS

ITEM#	DESCRIPTION	LIST PER UNIT	ITEM#	DESCRIPTION	LIST PER UNIT
LAYOUT BOOKS			TRACK PRODUCTS		
1	ALL SCALES CATALOG	N/C	104	SUPER FLEX TRACK	2.40
8	BASIC GUIDE TO MODEL RAILROADING	1.00	106	SUPER FLEX TRACK - 5 PACK - 5 PCS. TO BOX	11.00
9	SNAP LAYOUT BOOK	1.75	17	15" RADIUS TRACK—BULK	.55
11	CUSTOMLINE LAYOUT BOOK	4.25	18	22" RADIUS TRACK—BULK	.55
12	CUSTOMLINE WIRING BOOK	4.25	19	9" STRAIGHT TRACK—BULK	.55
13	CUSTOMLINE "6 RAILROADS" BOOKS	4.25	20	18" STRAIGHT TRACK—BULK	.55
14	CUSTOMLINE KINGSIZE LAYOUTS BOOK	6.00	21	9" STRAIGHT 6 PCS TO ENVELOPE	3.50
BRIDGES AND ACCESSORIES			22	6" STRAIGHT 4 PCS TO ENVELOPE	1.90
80	PIER SET 47 PC SET	9.50	23	3" STRAIGHT 4 PCS TO ENVELOPE	1.90
81	3" BRIDGE PIERS 4 PCS TO BOX	2.25	25	1 1/2" STRAIGHT 4 PCS TO ENVELOPE	1.90
82	PIER GIRDERS 4 PCS TO BOX	1.75	31	15" RADIUS 8 PCS TO ENVELOPE	3.55
83	WARREN BRIDGE KIT	3.50	32	1/2-15" RADIUS 4 PCS TO ENVELOPE	1.90
883	WARREN BRIDGE KIT N.S.	3.95	34	1/2-18" RADIUS 4 PCS TO ENVELOPE	1.90
84	DECK BRIDGE KIT	3.50	35	1/2-18" RADIUS 4 PCS TO ENVELOPE	1.90
884	DECK BRIDGE KIT N.S.	3.95	36	22" RADIUS 6 PCS TO ENVELOPE	3.55
85	PLATE GIRDER BRIDGE	3.25	38	30 DEGREE SNAP CROSSING	4.75
885	PLATE GIRDER BRIDGE N.S.	3.95	40	STRAIGHT TERMINAL 1 PC TO ENVELOPE	2.25
86	PONY TRUSS BRIDGE KIT	9.00	41	90 DEGREE SNAP CROSSING	4.75
886	PONY TRUSS BRIDGE KIT N.S.	9.00	42	TERMINAL JOINERS 24 SETS TO BOX 12 BOX TO CASE	1.60
87	CURVED CHORD BRIDGE KIT	15.00	43	BUMPERS 2 BUMPERS TO ENVELOPE	1.90
887	CURVED CHORD BRIDGE KIT N.S.	15.00	44	RERAILERS 3 PCS TO ENVELOPE	3.90
301	TURNTABLE MOTOR DRIVE	20.95	45	18" RAD. TERMINAL 1 PC TO ENVELOPE	2.25
302	TURNTABLE	16.00	47	TRACK ASSORTMENT	2.50
303	TURNTABLE N.S.	16.00	49	DEAD END UNCOUPLER 1 PC TO ENVELOPE	2.25
400	SNAP SAW	1.95	50	REMOTE CONTROL SNAP SWITCH—LEFT	10.75
ROADBED			51	REMOTE CONTROL SNAP SWITCH—RIGHT	10.75
100	3" ROADBED 12 SECTIONS TO PACKAGE 6 PACKAGES/CASE	1.60	52	SWITCH MACHINE REMOTE CONTROL—LEFT	5.50
100B	3" ROADBED 4 PCS TO BOX	6.40	53	SWITCH MACHINE REMOTE CONTROL—RIGHT	5.50
110	3" ROADBED Desert Tan 12 SECTIONS TO PACKAGE 6 PACKAGES/CASE	6.40	54	RAIL JOINERS—BRASS 8 UNITS TO DISP 4 OZ TO UNIT	1.50
111	3" ROADBED Gray Gravel 12 SECTIONS TO PACKAGE 6 PACKAGES/CASE	TBA	55	RAIL JOINERS—PLASTIC 8 UNITS TO DISP 2 OZ TO UNIT	.90
CROSSINGS			56	CONTROL BOX 12 PCS TO DISP	2.50
140	12 1/2 DEGREE CROSSING FOR USE WITH #4 TURNOUTS L OR R	4.95	60	MANUAL SNAP SWITCH—LEFT	6.50
141	19 DEGREE CROSSING FOR USE WITH #6 TURNOUTS L OR R	4.75	61	MANUAL SNAP SWITCH—RIGHT	6.50
142	25 DEGREE CROSSING FOR USE WITH #4 TURNOUTS L OR R	4.75	62	MANUAL SWITCH MACHINE—LEFT	1.50
143	30 DEGREE CROSSING	4.75	63	MANUAL SWITCH MACHINE—RIGHT	1.50
144	45 DEGREE CROSSING	4.75	65	UNDER TABLE SWITCH MACHINE	5.50
145	60 DEGREE CROSSING	4.75			
WIRING ACCESSORIES					
200	SNAP RELAY FOR ENERGIZING DEAD TRACKS, DEADEND SIGNALS & SIGNAL LIGHTS	6.50			
205	CONNECTOR	5.00			
210	TWIN	5.00			
215	SELECTOR	5.00			
220	CONTROLLER	5.00			
MARK 2 TURNOUTS					
230	WYE TURNOUT—BRASS	7.00			
231	#4 LEFT TURNOUT—BRASS	7.00			
232	#4 RIGHT TURNOUT—BRASS	7.00			
233	#6 LEFT TURNOUT—BRASS	7.00			
234	#6 RIGHT TURNOUT—BRASS	7.00			

ALL SCALES PRICE LIST

HO SCALE PRODUCTS HO SCALE PRODUCTS

ITEM#	DESCRIPTION	LIST PER UNIT	ITEM#	DESCRIPTION	LIST PER UNIT
TRACK SIDE ACCESSORIES			RAIL JOINERS AND CROSSINGS N. SILVER		
701	ELEVATED GATE TOWER KIT	4.50	170	RAIL JOINERS-N.S. 8 UNIT TO DISP 4 OZ TO UNIT	1.50
702	TRACKSIDE SHANTY KIT	4.50	171	19 DEGREE CROSSING	5.00
703	WATER TOWER KIT	5.75	172	25 DEGREE CROSSING	5.00
704	SIGNAL TOWER KIT	5.75	173	30 DEGREE CROSSING	5.00
705	TELEPHONE SHANTY & POLE KIT	3.00	174	45 DEGREE CROSSING	5.00
706	PASSENGER STATION KIT	7.50	175	60 DEGREE CROSSING	5.00
707	STATION PLATFORM KIT	3.50	176	90 DEGREE CROSSING	5.00
715	REFRESHMENT STAND KIT	4.25	177	12 1/2 DEGREE CROSSING FOR USE WITH #4 TURNOUT L OR R	5.50
750	LUMBER YARD & OFFICE BUILDING KIT	7.00	838	30 DEGREE SNAP CROSSING	5.00
760	ROADSIDE RESTAURANT KIT	7.25	842	TERMINAL JOINER 24 SETS PER BOX 12 BOX TO CASE	1.70
775	TELEPHONE POLES—12 TO SET	2.50			
776	FENCE & GATE KIT	2.50			
777	RUSTIC FENCE & GATE	2.50	MISCELLANEOUS ITEMS		
778	COWS & HORSES	2.50	101	BRASS RAIL—99 TO THE BUNDLE	26.00
779	SHEEP—12 WHITE, 1 BLACK	2.50	102	NICKEL SILVER RAIL—99 TO THE BUNDLE	27.00
790	FLAT CAR LOAD 4 GIRDER TO UNIT	2.00			
791	MILL LUMBER	2.50			
793	UNDECORATED FIGURES—24 PIECES	2.50	O SCALE PRODUCTS		
2540	TRACK PAIRS 12 UNIT PACK TO DISPLAY 2 OZ UNIT PACK	2.50	ITEM#	DESCRIPTION	LIST PER UNIT
NICKEL SILVER TRACK AND SWITCHES			"O" SCALE PRODUCTS		
88	STARTER SET N/S 27 PC SET	25.95	6000	3" FLEX TRACK	6.25
150	9" STRAIGHT TRACK—NICKEL SILVER	.60	6001	12" STRAIGHT TRACK	1.00
151	15" RADIUS TRACK—NICKEL SILVER	.60	6004	4" STRAIGHT TRACK	.50
152	18" RADIUS TRACK—NICKEL SILVER	.60	6010	24" RADIUS TRACK	1.00
153	22" RADIUS TRACK—NICKEL SILVER	.60	6014	1/2" RADIUS TRACK	.50
168	SUPER FLEX TRACK—NICKEL SILVER	2.50	6018	12" STRAIGHT TERMINAL TRACK	1.25
178	SUPER FLEX TRACK N/S 5 PACK - 5 PCS. TO BOX	11.50	6021	REMOTE CONTROL SWITCH—LEFT	8.75
			6022	REMOTE CONTROL SWITCH—RIGHT	8.75
602	9" RAIL REPLACEMENT FOR RAIL #83, #4 24 PC UNIT	5.50	6023	MANUAL SWITCH—LEFT	4.50
621	9" STRAIGHT TRACK 6 PCS TO ENVELOPE	3.75	6024	MANUAL SWITCH—RIGHT	4.50
622	6" STRAIGHT 4 PCS TO UNIT	2.00	6031	REMOTE CONTROL SWITCH MACHINE—LEFT	3.50
623	3" STRAIGHT 4 PCS TO UNIT	2.00	6032	REMOTE CONTROL SWITCH MACHINE—RIGHT	3.50
631	15" RADIUS 6 PCS TO ENVELOPE	3.75	6041	RAIL JOINERS 8 UNITS TO DISP 3 OZ TO UNIT	1.20
633	18" RADIUS 6 PCS TO ENVELOPE	3.75	6205	SLIDING DOOR BOX CAR	17.00
634	1/2-18" RADIUS 4 PCS TO UNIT	2.00	6215	GONDOLA UNDEC.	13.00
635	1/2-18" RADIUS 4 PCS TO UNIT	2.00	6225	40' STOCK UNDEC.	13.00
636	22" RADIUS 6 PCS TO ENVELOPE	3.75	6235	CABOOSE UNDEC.	17.00
840	STRAIGHT TERMINAL 1 PC TO ENVELOPE	2.40	6245	40' PLUG DOOR UNDEC.	13.00
843	BUMPERS 2 BUMPERS TO ENVELOPE	2.00	6265	70 TON ORE UNDEC.	12.00
844	RERAILERS 3 PCS TO UNIT	4.00			
845	18" RADIUS TERMINAL 1 PC TO ENVELOPE	2.40			
847	TRACK ASSORTMENT ASST OF SM STRAIGHT TRACK NICKEL-SILVER	2.40			
849	DEAD END UNCOUPLER 1 PC TO ENVELOPE	2.40			
850	REMOTE CONTROL SNAP SWITCH—LEFT	11.00			
851	REMOTE CONTROL SNAP SWITCH—RIGHT	11.00			
860	MANUAL SNAP SWITCH—LEFT	7.00			
861	MANUAL SNAP SWITCH—RIGHT	7.00			
MARK 2 TURNOUTS N. SIL.					
260	WYE MARK 2 TURNOUT N. SIL.	7.25			
261	#4 LEFT MARK 2 TURNOUT N. SIL.	7.25			
262	#4 RIGHT MARK 2 TURNOUT N. SIL.	7.25			
263	#6 LEFT MARK 2 TURNOUT N. SIL.	7.25			
264	#6 RIGHT MARK 2 TURNOUT N. SIL.	7.25			

ALL SCALES PRICE LIST

ALL SCALES PRICE LIST

N SCALE PRODUCTS

N SCALE PRODUCTS

PART#	DESCRIPTION	LIST PRICE UNIT	PART#	DESCRIPTION	LIST PRICE UNIT
"N" LAYOUT BOOKS			"N" LOCOS		
6	"N" GAUGE LAYOUT BOOK	1.75	4260	UNDECORATED ALCO RS-11	49.00
7	"NINE" LAYOUT BOOK	4.25	4264	L & N ALCO RS-11	49.00
"N" TRACK PRODUCTS			4330	UNDECORATED EMD GP9	59.95
2500	SUPER FLEX TRACK 1 PC. (SECTION) 1.60	2.10	4400	UNDECORATED FB RS-1	74.95
2501	5" STRAIGHT TRACK 6 PCS TO PACK 1 PACK @ 1.60	1.90	4401	UNDECORATED RB RS-1	74.95
2509	STRAIGHT TRACK ASSORTMENT 1 ASSORTMENT BOX 1.60	2.15	4406	SOO LINE RS-1	74.95
2510	9 1/2" RADIUS TRACK 6 PCS TO PACK 1 PACK @ 1.60	1.90	4407	BALTIMORE & OHIO RS-1	74.95
2511	1/2-9 1/2" RADIUS TRACK 6 PCS TO PACK 1 PACK @ 1.25	1.50	4409	GULF, MOBILE & OHIO RS-1	74.95
2520	11" RADIUS TRACK 6 PCS TO PACK 1 PACK @ 1.60	1.90	4410	S P & S RS-1	74.95
2521	1/2-11" RADIUS TRACK 6 PCS TO PACK 1 PACK @ 1.25	1.50	4412	SOUTHERN RS-1	74.95
2526	19" RADIUS TRACK 6 PCS TO PACK 1 PACK @ 1.60	1.90	GE U25B PHASE IIa		
2532	RERAILER TRACK 3 PCS TO PACK 1 PACK @ 1.25	1.50	4451	SANTA FE	79.95
2534	N SCALE RAIL 250' TO THE BDL	75.00	4452	PENNSYLVANIA	79.95
2536	RAIL JOINERS 6-1.25 UNIT PACKS TO DISPLAY	1.50	4453	UNION PACIFIC	79.95
2538	BUMPERS 2 BUMPERS TO UNIT PACK @ 1.25	1.50	4454	CONRAIL	79.95
2538	PLASTIC JOINERS 6-606 UNITS TO DISPLAY	70	4455	C & O #2525	79.95
2539	TERMINAL JOINERS 24-1.25 UNITS TO DISPLAY	1.70	4456	C & O #2537	79.95
2540	TRACK NAILS 2 OZ. UNIT PACK @ 1.65 12 UNIT PACK TO DISPLAY	2.50	4457	FRISCO #812	79.95
"N" ACCESSORIES			4458	FRISCO #814	79.95
2541	PIER SET 25 PCS. TO BOX	5.50	4459	SOUTH PAC. #6706	79.95
2542	PIER GIRDER 4 PCS. TO BOX	1.75	4460	SOUTH PAC. #6714	79.95
2543	BRIDGE PIER 3 PCS. TO BOX	1.75	GE U25B PHASE IIb		
2801	TELEPHONE POLES 12 TO BOX	1.50	4471	BURLINGTON NORTHERN	79.95
2826	VIADUCT KIT	3.00	4472	ERIE LACKAWANNA	79.95
"N" BRIDGES			4473	SEABOARD SYSTEM	79.95
2546	WARREN BRIDGE 2.25 PER PC.	2.75	4474	ROCK ISLAND	79.95
2547	DECK BRIDGE 2.25 PER PC.	2.75	4475	N Y C #2525	79.95
2548	PLATE GIRDER BRIDGE 2.25 PER PC.	2.75	4476	N Y C. #2529	79.95
"N" CROSSINGS			4477	NEW HAVEN	#2502 79.95
2564	15 DEGREE	4.75	4478	NEW HAVEN	#2509 79.95
2565	20 DEGREE	4.75	4479	GREAT NO.	#2500 79.95
2566	30 DEGREE	4.75	4480	GREAT NO.	#2502 79.95
2567	45 DEGREE	4.75	4481	CB&O	#100 79.95
2568	60 DEGREE	4.75	4482	CB&O	#105 79.95
2569	90 DEGREE	4.75	"N" TURNOUTS USA SERIES		
"N" TURNOUTS			"N" MODEL RAILROAD SETS		
2580-1	STANDARD REMOTE SWITCH LEFT	12.75	4448-1	PENNSYLVANIA	47.00
2581-1	STANDARD REMOTE SWITCH RIGHT	12.75	4448-2	SOUTHERN	47.00
2582-1	STANDARD MANUAL SWITCH LEFT	7.50	4448-3	SANTA FE	47.00
2583-1	STANDARD MANUAL SWITCH RIGHT	7.50	4448-4	UNION PACIFIC	47.00
2580-1	R/C SWITCH MACHINE LEFT	6.25	4448-5	BALTIMORE & OHIO	47.00
2581-1	R/C SWITCH MACHINE RIGHT	6.25	4448-6	CANADIAN	47.00
"N" TURNOUTS			"N" SETS w/LOCOMOTIVES		
2584	STANDARD REMOTE SWITCH #6 LEFT	17.95	4448-10	CONRAIL	98.45
2585	STANDARD REMOTE SWITCH #6 RIGHT	17.95	4448-11	NORFOLK & WESTERN	98.45
2580	R/C SWITCH MACHINE LEFT	9.95	4448-12	PENNSYLVANIA	98.45
2581	R/C SWITCH MACHINE RIGHT	9.95	4448-13	ASSORTMENT (4 EACH OF ABOVE)	98.45

HO LOCOMOTIVES

ITEM#	DESCRIPTION	LIST PER UNIT	ITEM#	DESCRIPTION	LIST PER UNIT
7089	ST. L.S-W (Southern Pacific) RSD4-5	59.95	8117	NYC RS-1	72.95
7092	NORFOLK & WESTERN RS-11	47.00	8118	ANN ARBOR RS-1	72.95
7093	SOUTHERN PACIFIC RS-11	47.00	8119	RUTLAND RS-1	72.95
7096	CONRAIL RS-11	79.95	8120	AMTRAK RS-1	72.95
7097	MAINE CENTRAL RD #801 RS-11	79.95	8121	SOUTHERN RS-1	72.95
7098	MAINE CENTRAL RD #802 RS-11	79.95	8122	C.N.J. RS-1	72.95
7099	NORTHERN PACIFIC RS-11	79.95	8123	GREAT NORTHERN RS-1	79.95
7100	NEW HAVEN RS-11	79.95	8124	MILWAUKEE ROAD RS-1	79.95
8031	SPOKANE, PORT & SEA C425	54.95	8125	SUSQUEHANNA RS-1	79.95
8032	BURLINGTON NORTHERN C425	54.95	8126	SANTA FE #2395 RS-1	79.95
8033	CHICAGO & N'WESTERN C425	54.95	8127	SANTA FE #2395 RS-1	79.95
8035	PENNSYLVANIA C425	54.95	8150	LEHIGH VALLEY RS-3	79.95
8036	NORFOLK & WESTERN C425	54.95	8151	RIO GRANDE RS-3	79.95
8037	CONRAIL C425	54.95	8152	CANADIAN NATIONAL RS-3	79.95
8056	ERIE LACKAWANNA C424 (I)	79.95	8153	SEABOARD A.L. RS-3	79.95
8057	ERIE LACKAWANNA C424 (I)	79.95	NEW LOCOS		
8058	READING C424 (I)	79.95	8200	UNDECORATED GP-7	TBA
8059	D & H C424 (I)	79.95	8201	UNDECORATED * GP-7	TBA
8060	PENNSYLVANIA C424 (I)	79.95	8202	CB & O #253 GP-7	TBA
8070	UNDECORATED S-2	62.95	8203	CB & O #265 GP-7	TBA
8071	RIO GRANDE S-2	62.95	8204	SANTA FE * #2692 GP-7	TBA
8072	UNION PACIFIC S-2	62.95	8205	SANTA FE #2752 GP-7	TBA
8073	PENNSYLVANIA S-2	62.95	8206	CANADIAN PACIFIC * #8409 GP-7	TBA
8074	NEW YORK CENTRAL S-2	62.95	8207	CANADIAN PACIFIC * #8411 GP-7	TBA
8075	BALTIMORE & OHIO S-2	62.95	8208	RIO GRANDE * #5100 GP-7	TBA
8076	SEABOARD AIR LINE S-2	62.95	8209	RIO GRANDE * #5112 GP-7	TBA
8100	UNDECORATED (F.B.) RS-1	67.95	8210	ERIE LACKAWANNA * #1217 GP-7	TBA
8101	UNDECORATED (R.B.) RS-1	67.95	8211	ERIE LACKAWANNA #1401 GP-7	TBA
8102	ROCK ISLAND RS-1	67.95	8212	PENNSYLVANIA * #8508 GP-7	TBA
8103	SANTA FE #2396 RS-1	67.95	8213	PENNSYLVANIA #8797 GP-7	TBA
8104	SANTA FE #2394 RS-1	67.95	8214	SOUTHERN #2067 GP-7	TBA
8105	PENNSYLVANIA #5906 RS-1	67.95	8215	SOUTHERN * #2185 GP-7	TBA
8106	PENNSYLVANIA #9914 RS-1	67.95	8216	UNION PACIFIC * #703 GP-7	TBA
8107	SOO LINE RS-1	67.95	8217	UNION PACIFIC * #718 GP-7	TBA
8108	NEW YORK CENT. #9900 RS-1	67.95	8218	WESTERN MARYLAND #21 GP-7	TBA
8109	NEW YORK CENT. #6109 RS-1	67.95	8219	WESTERN MARYLAND #23 GP-7	TBA
8110	CHICAGO NO. WESTERN RS-1	67.95	8220	ROCK ISLAND #1202 GP-7	TBA
8111	BALTIMORE & OHIO RS-1	67.95	8221	ROCK ISLAND #1300 GP-7	TBA
8112	NEW HAVEN RS-1	67.95	8222	CINCHFIELD #902 GP-7	TBA
8113	GULF, MOBILE & OHIO RS-1	67.95	8223	CINCHFIELD * #913 GP-7	TBA
8114	KCS RS-1	72.95	* DYNAMIC BRAKES		
8115	SP&S RS-1	72.95			
8116	SANTA FE RS-1	72.95			

N SCALE FREIGHT CARS

N Scale Freight Cars are priced between \$5.75 and \$7.25 each.